



# INSTALLATION INSTRUCTIONS

Accessory

**BACKUP SENSOR**

Application

**2005 RL**

Publications No.  
**BII 27024-28943**

Issue Date  
**MARCH 2005**

## PARTS LIST

**Backup Sensor Attachment Kit  
P/N 08V67-SJA-200A**

Control unit

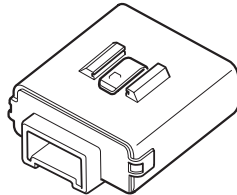

Beeper

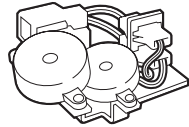

Backup sensor harness

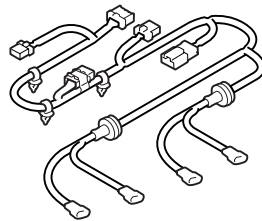

Control unit bracket

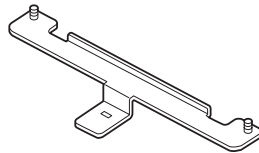

Short bracket

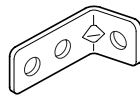

3 Flange nuts



Washer bolt



Flange bolt



8 Wire ties

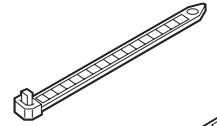

2 Long wire ties

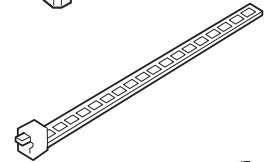

4 Wire ties with clip

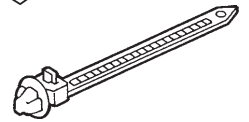

Spring nut



Owner's Manual



Fuse label

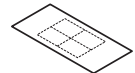

EPT sealer

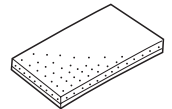

**Back-up Sensor Kit**

**P/N 08V67-SHJ-1XX**

**P/N 08V67-S3V-2XX**

**NOTE: Refer to Parts Information Bulletin (PIB)  
B04-0013 for the proper color sensors.**

2 Center sensors

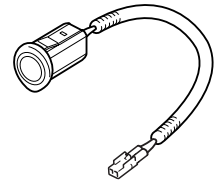

2 Corner sensors

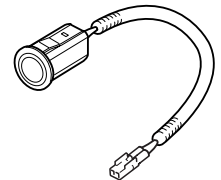

2 Spacers

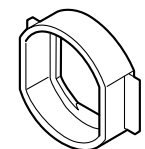

## TOOLS AND SUPPLIES REQUIRED

Phillips screwdriver  
Flat-tip screwdriver  
Ratchet  
8 mm and 10 mm Sockets  
Torque wrench  
Pushpin  
Drill  
3 mm Drill bit  
22 mm and 26 mm Hole saws  
Masking tape  
Tape measure (metric)  
Eye protection (safety goggles, face shield, etc.)  
10 mm Combination wrench  
Blanket  
File  
Diagonal cutters

## Illustration of the Backup Sensor Installed on the Vehicle

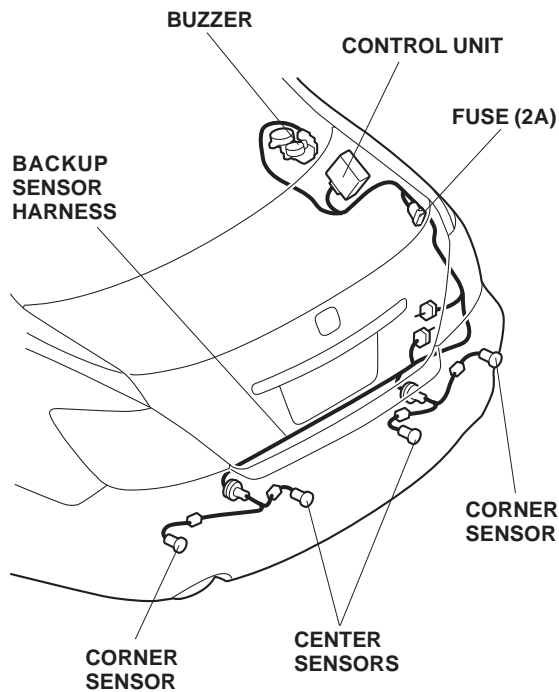

## INSTALLATION

**Customer Information:** The information in this installation instruction is intended for use only by skilled technicians who have the proper tools, equipment, and training to correctly and safely add equipment to your vehicle. These procedures should not be attempted by "do-it-yourselfers."

1. Make sure you have the anti-theft codes for the radio and navigation system, then write down the radio station presets.
2. Disconnect the negative cable from the battery.

### Installing the Sensors in the Bumper

3. Remove the two self-tapping screws and the four clips that secure the rear bumper. Remove the rear bumper. Set the bumper on a blanket.

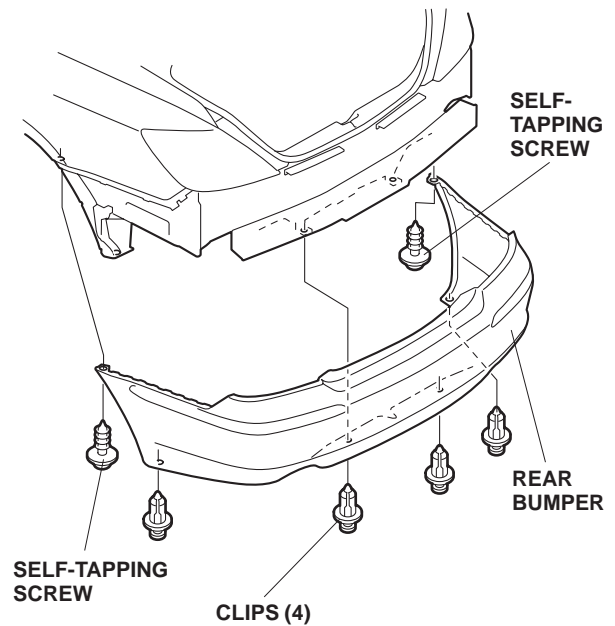

4. On the inside of the rear bumper, locate the four cross marks (without the circles). Using a pushpin, pierce through the rear bumper at each of the four marks.

NOTE: There are several markings on the inside of the rear bumper, make certain that you locate the proper cross marks.

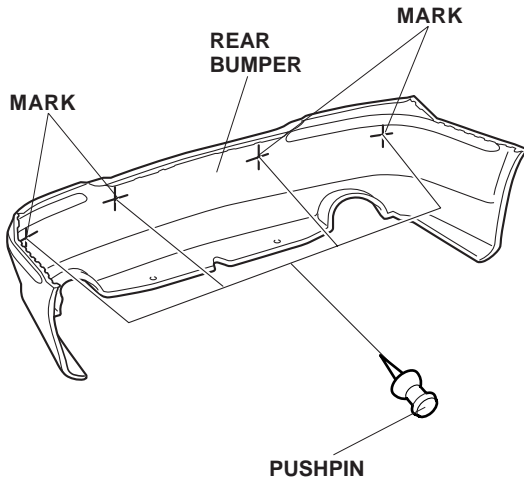

5. While wearing eye protection, drill a 3 mm hole through the four marks on the rear bumper.

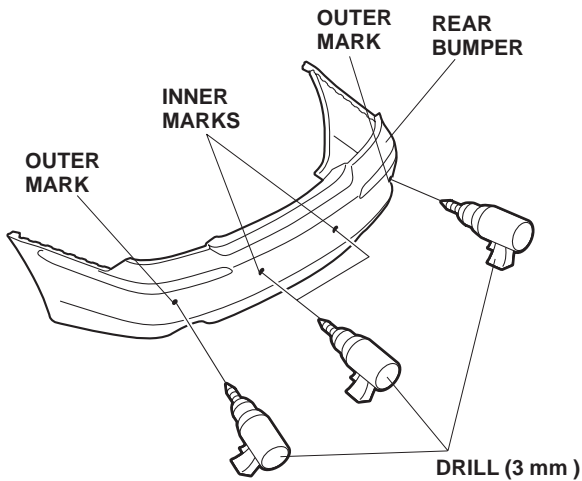

6. While wearing eye protection, drill a 22 mm hole through each of the two outer marks, and a 26 mm hole through each of the two inner marks. Remove any burrs from the edges of the holes.

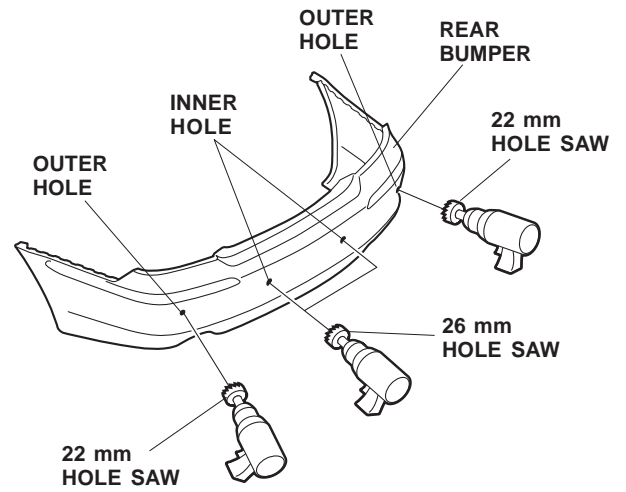

- Slide the two corner sensors into the two 22 mm holes with the harness towards the bottom. Do not push the center of the sensors; that may cause damage.

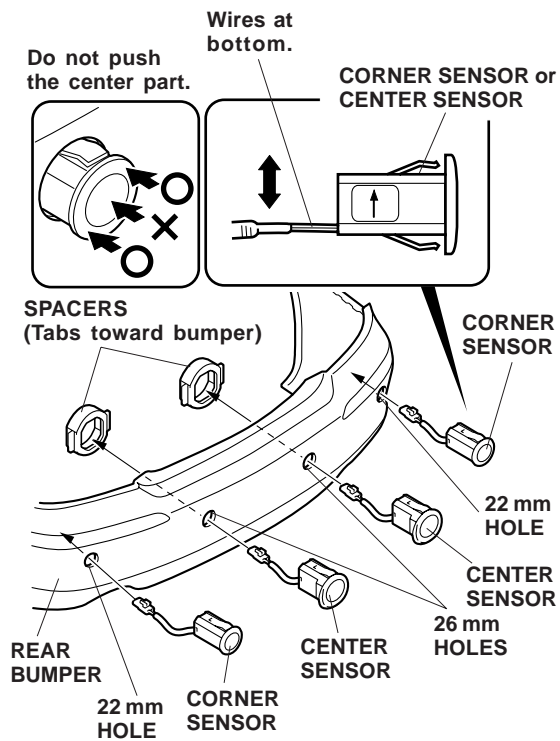

- Slide the two center sensors into the 26 mm holes with the harness towards the bottom. Secure the two center sensors with a spacer behind the bumper. Do not push the center of the sensor; that may cause damage.

### Routing the Backup Sensor Harness

- Open the trunk lid, and remove the spare tire lid.

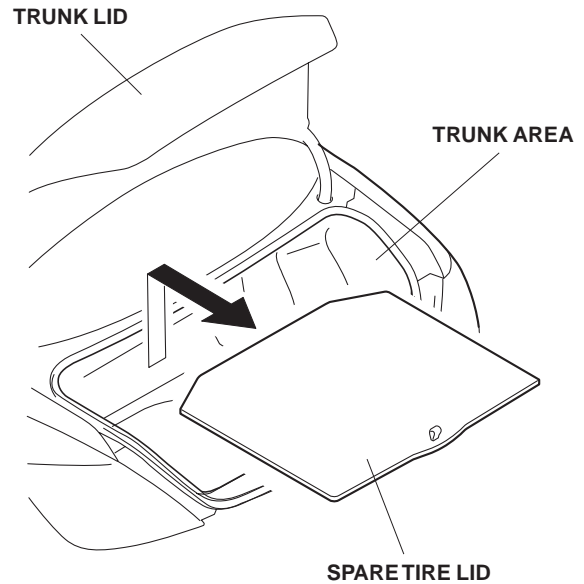

- Remove the weatherstrip as needed, and remove the rear trim panel (four clips and two retaining tabs).

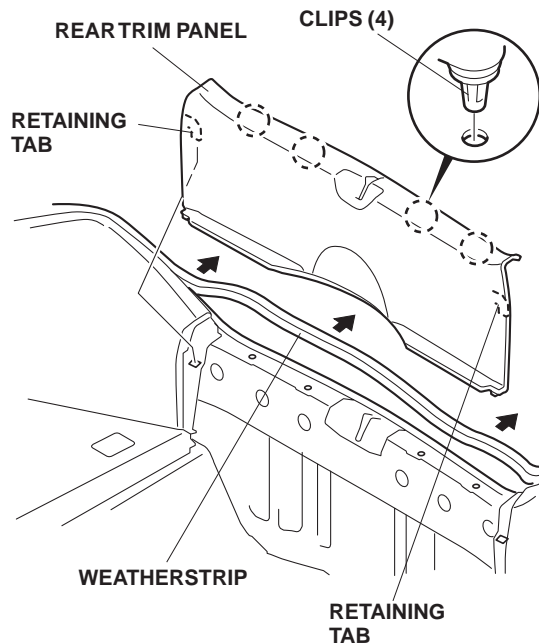

11. Remove the trunk hook (one clip). Open the covers on the tie-down hooks. Remove the screws and the tie-down hooks.
  - Insert a plastic trim tool at the edge of the tie-down hook cover and pry it open.
  - Take care not to damage the tie-down hook cover when opening it.

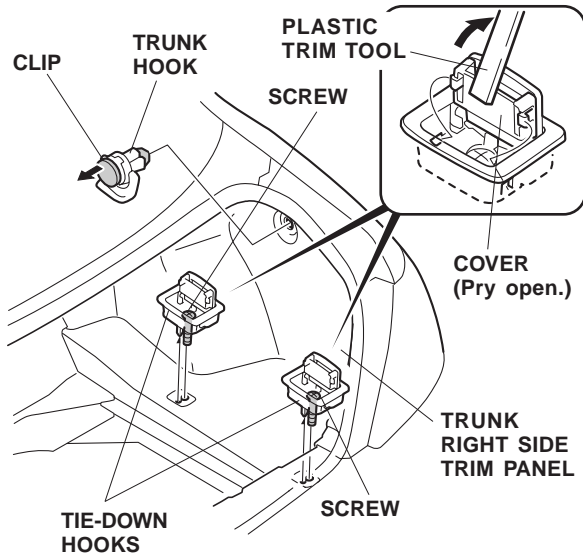

12. Remove the right weatherstrip in the area shown. Remove one clip and turn up the trunk front lining where the clip has been removed.
13. Remove two clips and remove the trunk right side trim panel.

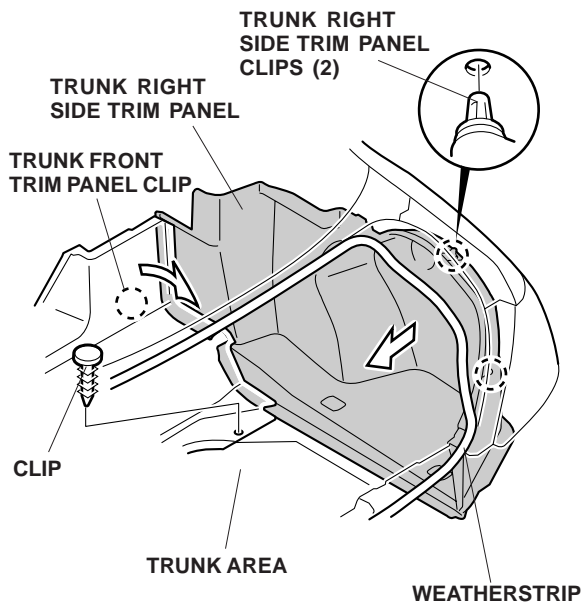

14. Remove one retaining tab, disconnect the vehicle connector, and remove the trunk light.
15. Remove seven clips from the trunk upper trim panel, remove two clips from the cover of the vehicle navigation unit, then remove the trunk upper trim panel. Place your hand onto the rear trunk upper trim panel when removing the clips from the vehicle navigation unit. Holding the cover of the vehicle navigation unit and pulling the trunk upper trim panel may damage the trim panel.

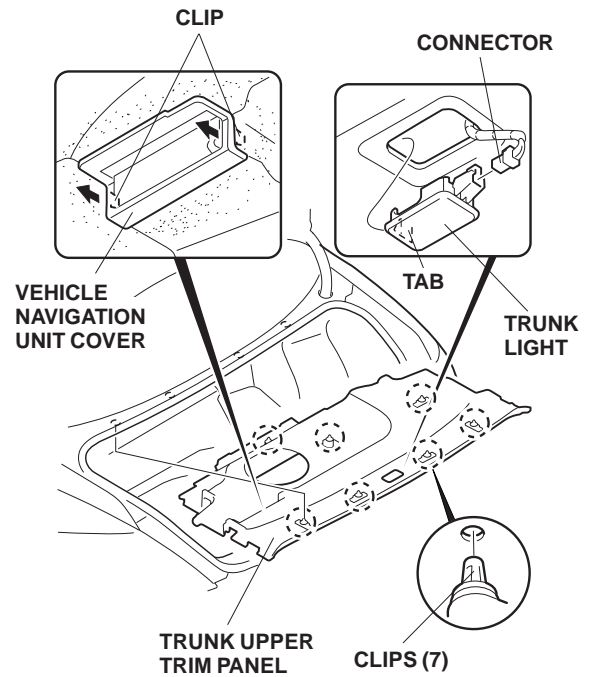

16. Slide the control unit bracket into the control unit. Install the flange nuts and turn them three turns.

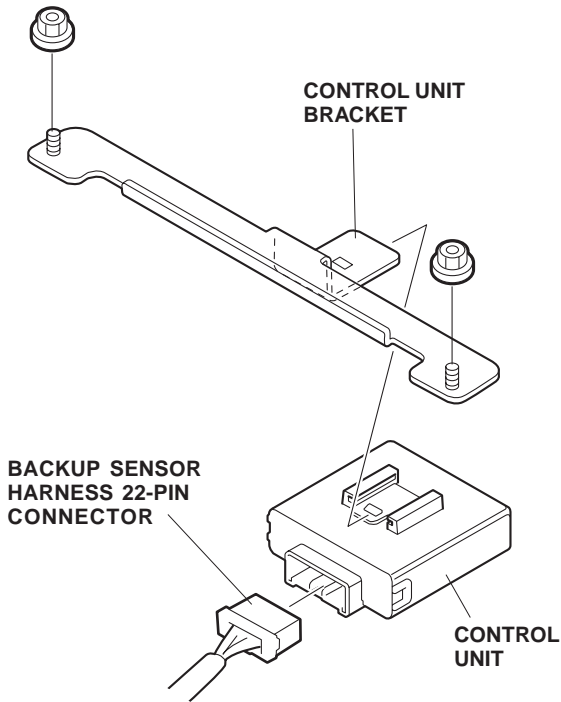

17. Plug the backup sensor harness 22-pin connector into the control unit.
18. Install the control unit and bracket to the inside of the vehicle panel and secure it with two flange nuts. Pull the backup sensor harness through the hole in the vehicle panel.

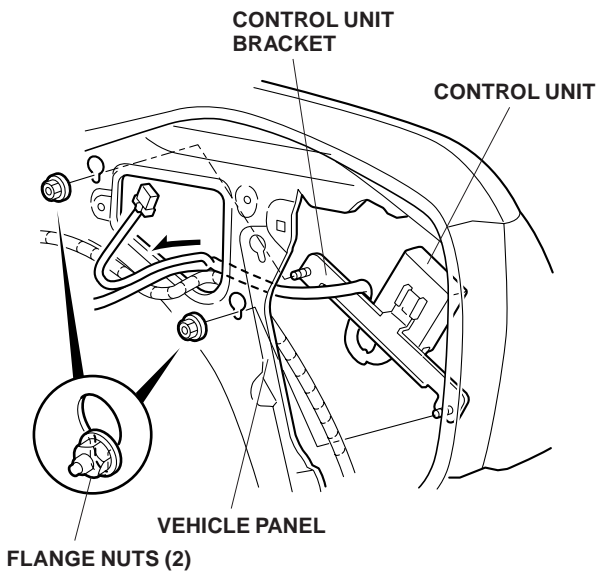

19. Plug the backup sensor harness 5-pin connector into the beeper.

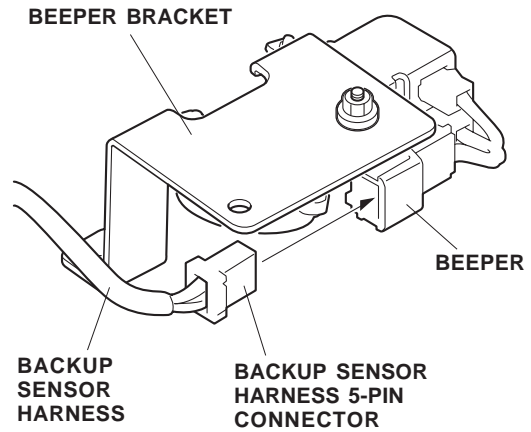

20. Remove the vehicle harness from the vehicle panel (one clip), then cut the clip on the vehicle harness with diagonal cutters. Take care not to damage the vehicle harness when you cut off the clip.

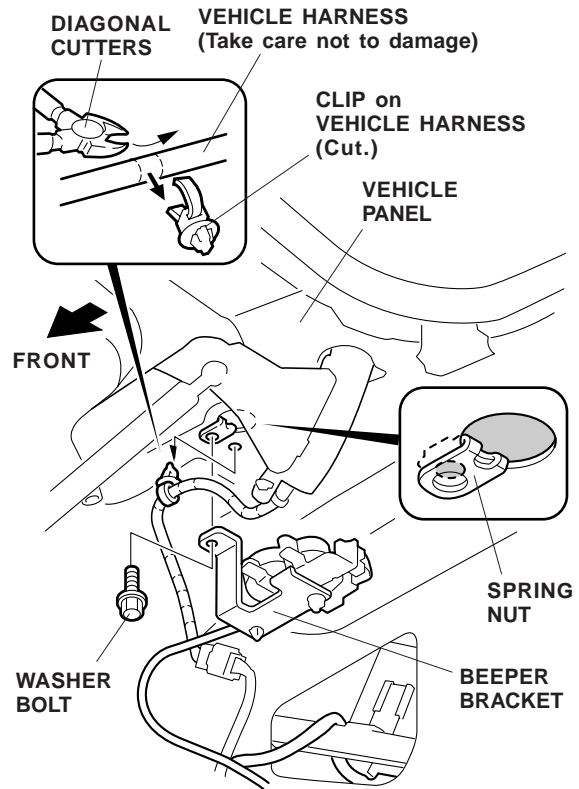

21. Install a spring nut by inserting it into the vehicle panel. Install the beeper bracket with one washer bolt. Close the trunk lid and check that the moving part of the trunk lid does not come in contact with the beeper or beeper bracket.

22. Secure the wire tie with clip to the vehicle harness. Attach the clip to the hole in the beeper bracket. Be sure to attach the wire tie with clip to the vehicle's harness in the position where you cut off the clip before.

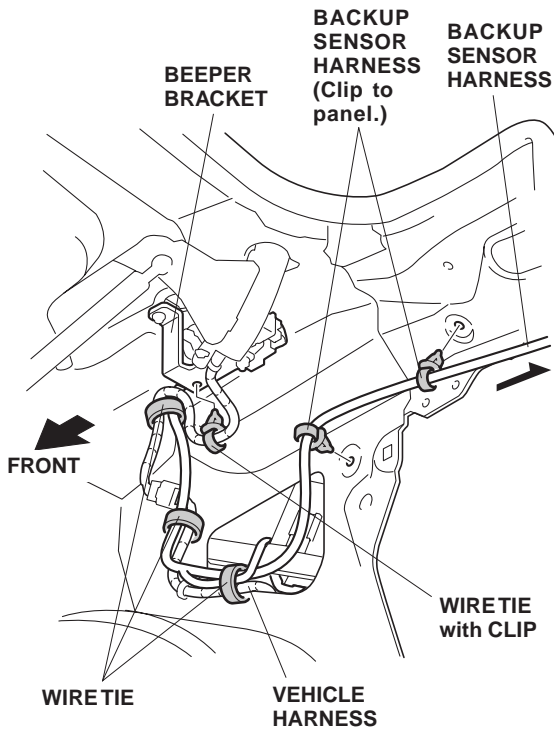

23. Route the backup sensor harness as shown. Secure the backup sensor harness to the vehicle harness with three wire ties, and attach the two clips on the backup sensor harness to the holes in the body panel as shown.

24. Remove the nut from the vehicle panel, install the short bracket, then secure it with the removed nut. Route the backup sensor harness to the rear side of the vehicle. Then attach the fuse label (2A) to the fuse case of the backup sensor harness.

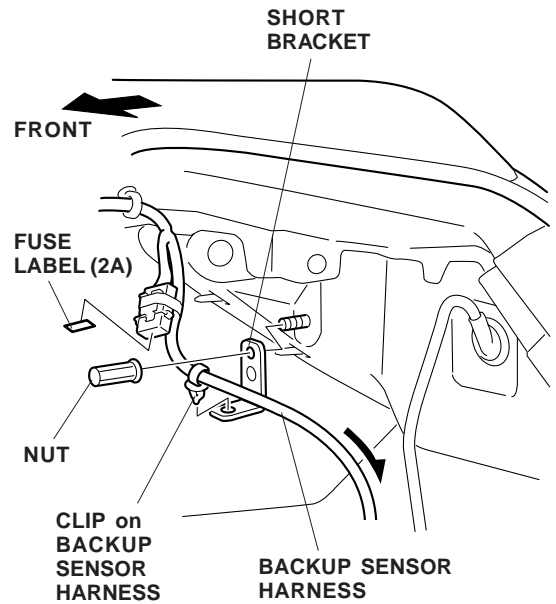

25. Attach the clip on the backup sensor harness to the short bracket installed in step 24.
26. Disconnect the vehicle 5-pin connector and insert the 5-pin connector of the backup sensor harness in between the vehicle harness.

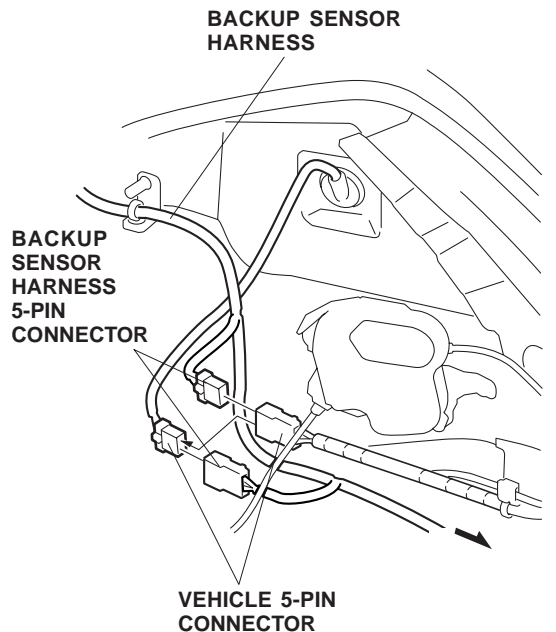

27. Inside the trunk, push the two grommets out and discard.

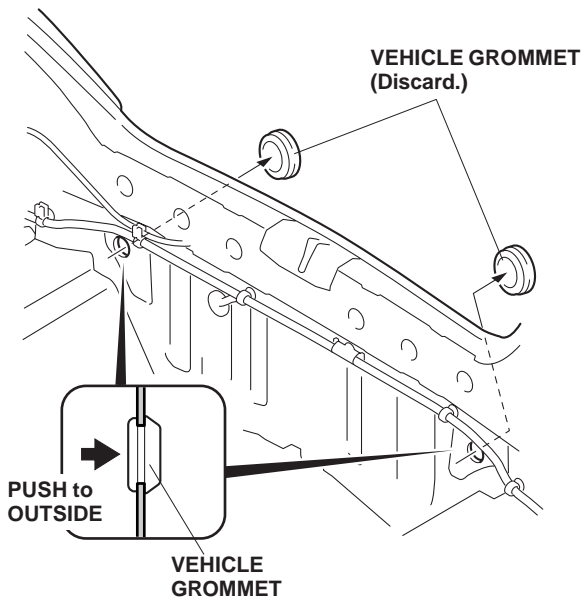

28. Continue to route the backup sensor harness (right and left) along the vehicle harness. Pull the two 2-pin connectors out through each right and left hole where the grommets were removed.

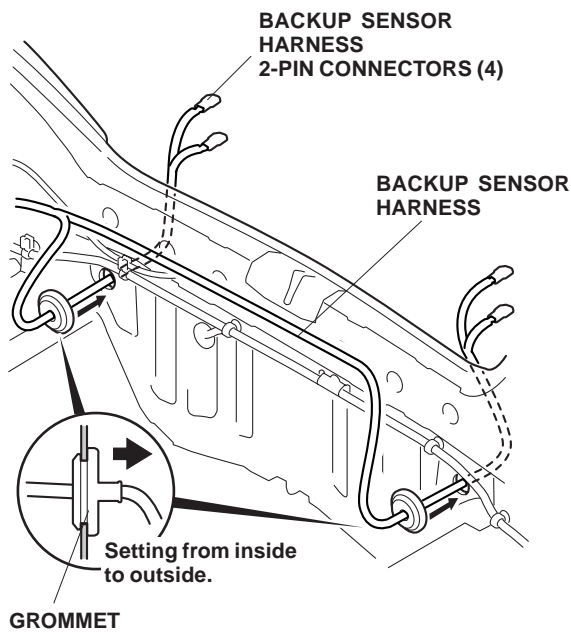

29. Seat the grommets on the backup sensor harness in the grommet holes.

30. Secure the backup sensor harness to the vehicle harness with the five wire ties in the area shown.

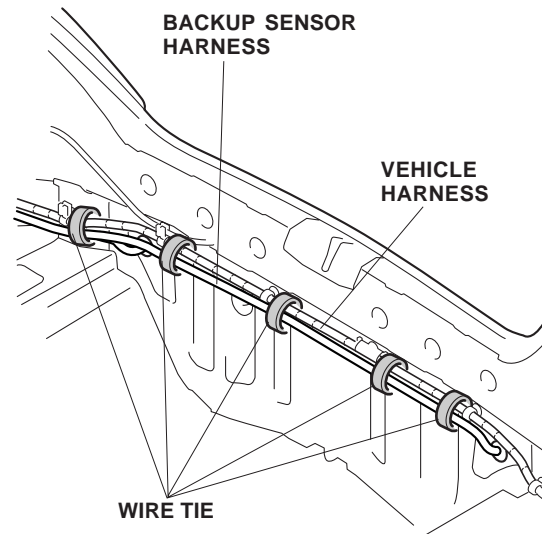

31. Cut the EPT sealer in half and attach the two halves to the backup sensor harness at each of the green tape areas. Secure the harness to the bumper beam with two wire ties.

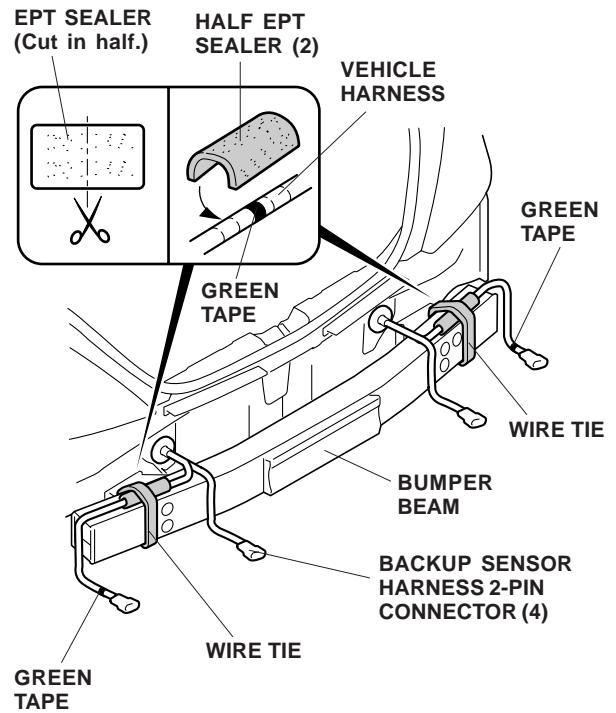



32. Connect the two outer 2-pin connectors of the backup sensor harness to the corner sensors.

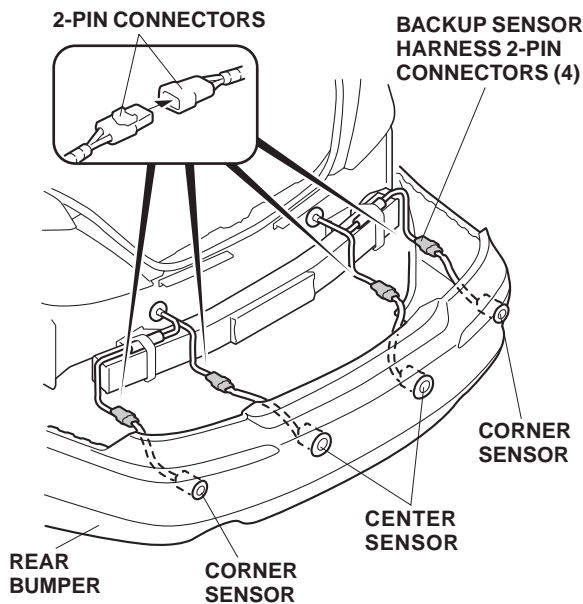

33. Connect the two inner 2-pin connectors from the backup sensor harness to the inner center sensors, then reinstall the rear bumper. Check that all clips and retaining tabs are installed securely.
34. Check that all wire harnesses and cables are routed properly and that all connectors are plugged in.
35. Reinstall all removed parts.
36. Reconnect the negative cable to the battery.
37. Enter the anti-theft codes for the radio and navigation systems, then enter the customer's radio presets.
38. Reset the clock.
39. Check that the backup sensors work properly as described in the Owner's Manual supplied with the backup sensor kit.  
  
NOTE: Whenever the battery is disconnected, the driver's window AUTO function is disabled.
40. Start the engine. Push down on the driver's window switch until the window is fully open, then hold the switch for 2 seconds or more.
41. Pull up on the driver's window switch to close the window completely, then hold the switch for 2 seconds or more.
42. Lower and raise the window to check operation of the driver's window AUTO function.