

PARTS LIST

Left side step

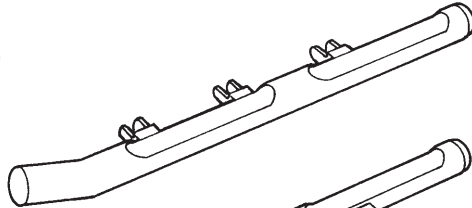

Right side step

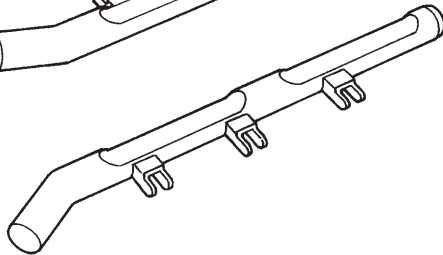

2 "A" brackets

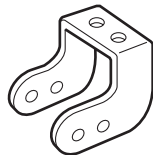

2 "B" brackets

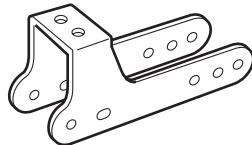

4 "AB" Brackets

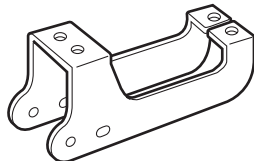

24 Long flange bolts



32 Short flange bolts



32 Flange nuts



TOOLS AND SUPPLIES REQUIRED

- Ratchet
- 13 mm Socket
- 13 mm Combination wrench
- Blanket
- Torque wrench

INSTALLATION

Customer Information: The information in this installation instruction is intended for use only by skilled technicians who have the proper tools, equipment, and training to correctly and safely add equipment to your vehicle. These procedures should not be attempted by "do-it-yourselfers."

NOTE:

- Thoroughly clean the bottom of the body between the front and rear wheels.
- Be careful not to damage the body paint finish. To prevent damage, place the blanket under the side step during the installation.
- These instructions show the left side step being installed; the same procedure applies to installing the right side step.

1. Assemble the two front bracket assemblies using brackets "A" and "B" along with four short flange bolts, and four flange nuts. Leave the nuts and bolts loose at this time.

Front Bracket Assembly:

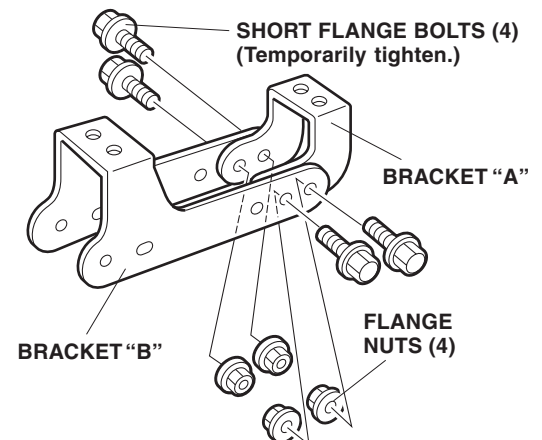

- On the left side of the vehicle, install one assembled bracket to the front of the vehicle, one "AB" bracket to the center, and one to the rear using twelve long flange bolts. Thread the long flange bolts in about three or four turns.

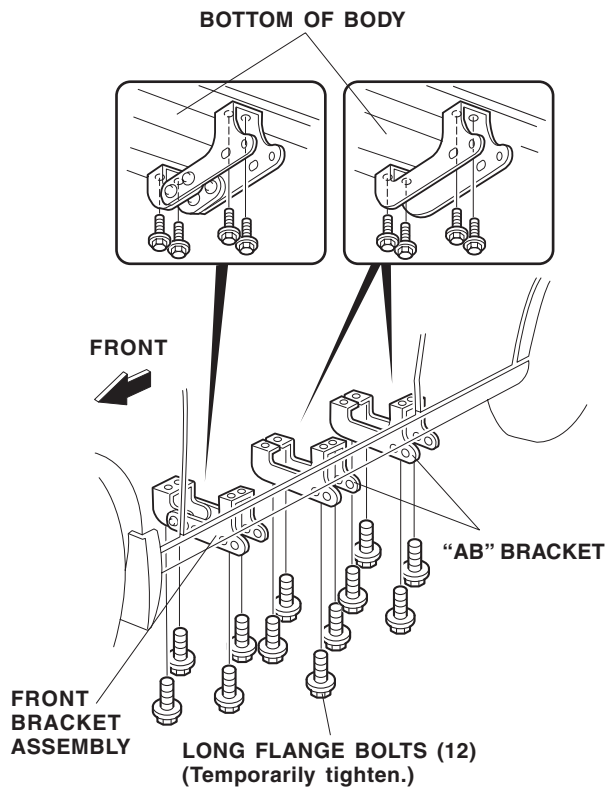

- Position the left side step to the brackets using twelve short flange bolts and twelve flange nuts. Thread the short flange bolts in about three or four turns.

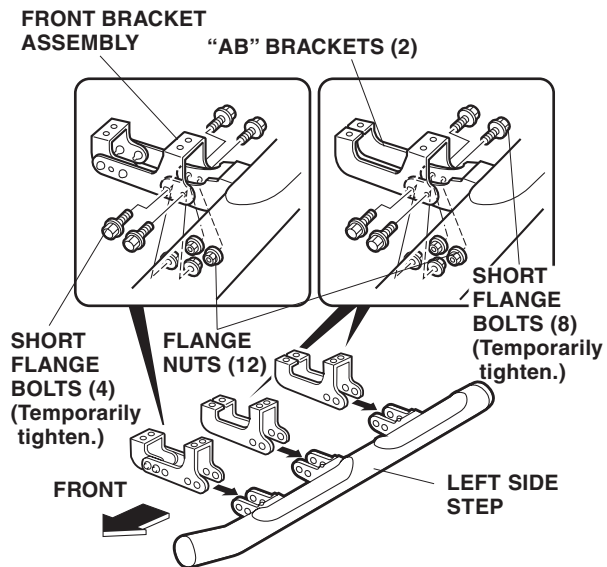

- Adjust the location of the left side step so that even clearance is obtained between the side step and body, then tighten the long flange bolts. Torque the long flange bolts to 27 N·m (20 lb-ft).

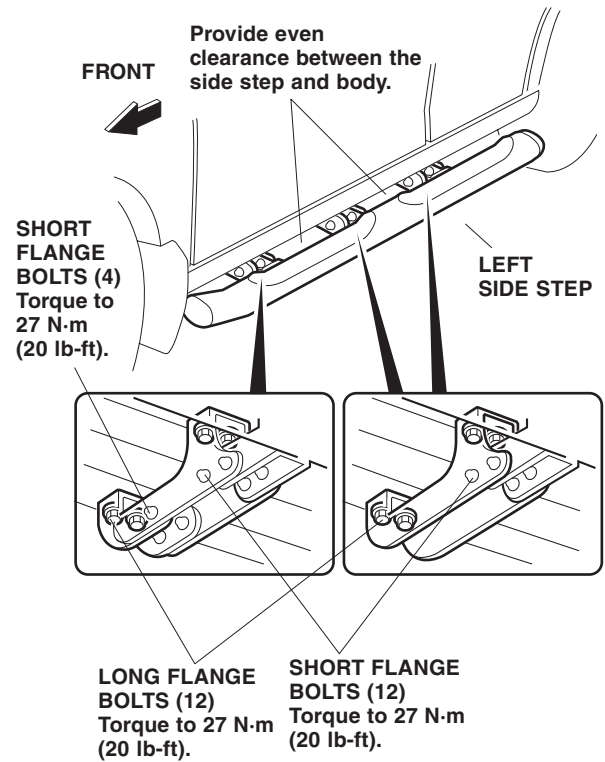

- Torque the twelve short flange bolts you installed in step 3 to 27 N·m (20 lb-ft).
- Torque the four short flange bolts you installed in step 1 to 27 N·m (20 lb-ft).
- Repeat steps 2 through 6 to install the side step on the right side of the vehicle.