



INSTALLATION INSTRUCTIONS

Accessory

FRONT LOWER TRIM
P/N 08P01-S3V-210A (GRAY)
P/N 08P01-S3V-220A (SILVER)

Application

2004 MDX

Publications No.

BII 25804

Issue Date

SEP 2003

PARTS LIST

Front lower trim

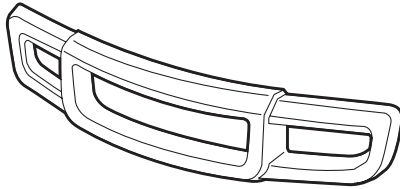

License plate base

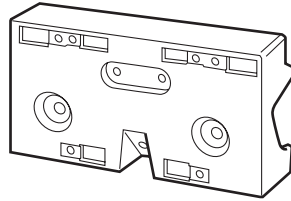

Cap A



2 Caps B



10 Screws (short)



13 Washers



3 Flange nuts



3 Screws (long)

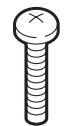

4 Spring nuts



License plate frame

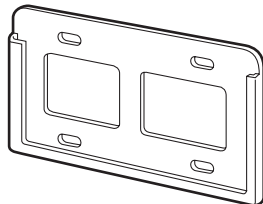

4 Washer-screws



TOOLS AND SUPPLIES REQUIRED

Phillips screwdriver

Flat-tip screwdriver

10 mm Socket

Ratchet

Drill

3 mm, 8 mm and 9 mm Drill bits

File

Blanket

Center punch

Felt-tip pen

INSTALLATION

Customer Information: The information in this installation instruction is intended for use only by skilled technicians who have the proper tools, equipment, and training to correctly and safely add equipment to your vehicle. These procedures should not be attempted by "do-it-yourselfers."

NOTE:

- Before removing parts, note their locations so that they can be installed in their original locations properly.
- Be careful not to damage the front bumper and other finished surfaces of the body.
- To prevent damage to the front bumper and front lower skirt, rest the front bumper on a blanket during the installation.

1. Position the license plate base on the front lower trim by aligning the hole in the bottom with the mark at the center of the bottom of the front lower trim as shown. Using a felt-tip pen, mark the front lower trim at the centers of the two holes in the front of the license plate base.

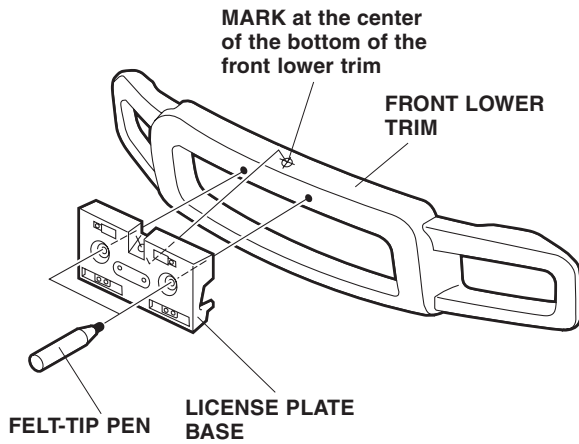

2. Remove the license plate base and lightly center punch the three marks (one provided at the center of the bottom of the front lower trim and two you just made). Using drill and drill bits, drill an 8 mm hole through each center-punched location. First drill with a 3 mm bit, and finish with an 8 mm bit.
 - Remove any burrs from the edges of the holes with a file.

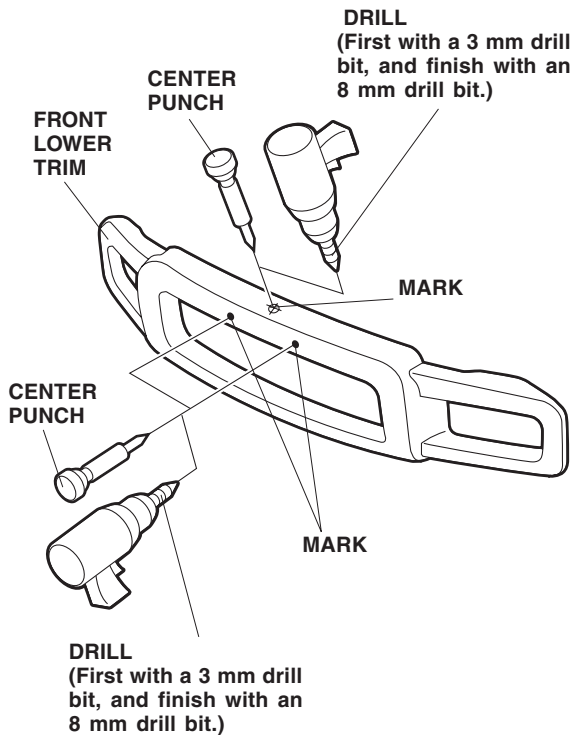

3. Slide the four spring nuts onto the license plate base through the cutouts as shown.

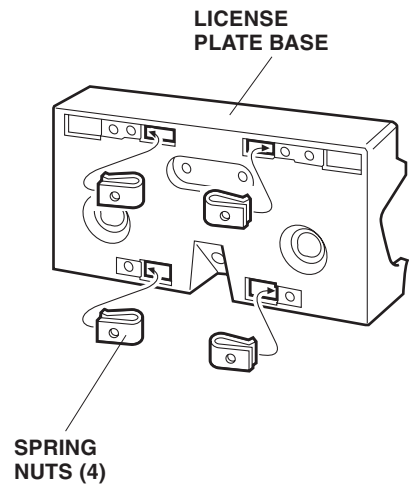

4. Attach the license base plate to the front lower trim with the three long screws, three washers and three flange nuts.

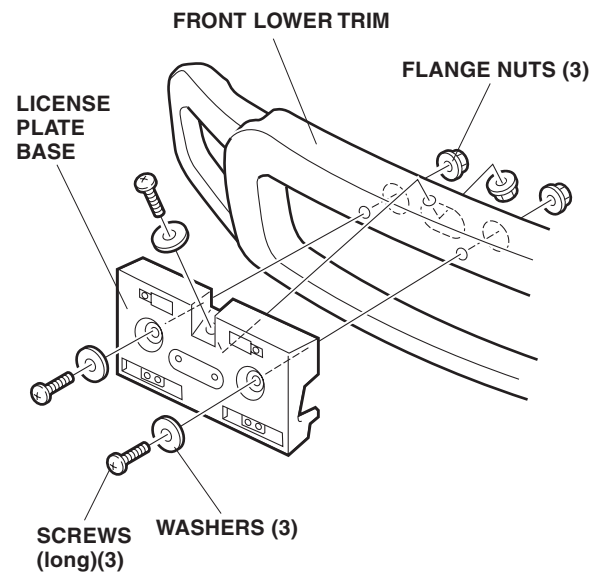

5. Use isopropyl alcohol to clean the areas where the caps A and B (one cap A and two caps B) will attach.
6. Remove the adhesive backings from the caps A and B.
7. Attach the cap A by aligning it with the mark at the center of the back of the front lower trim, and caps B by aligning them with the marks on both sides.

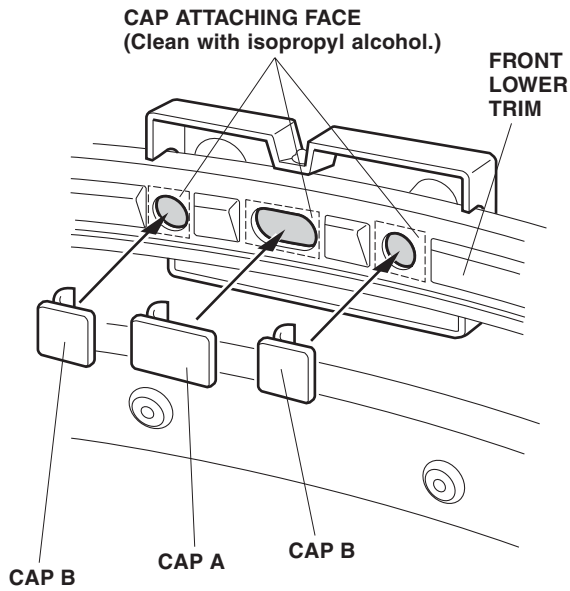

8. Remove the two self-tapping screws, seven clips and four bolts that secure the front bumper.
 - If the vehicle is equipped with optional fender flares, remove the top inner fender screws that secure the bumper.

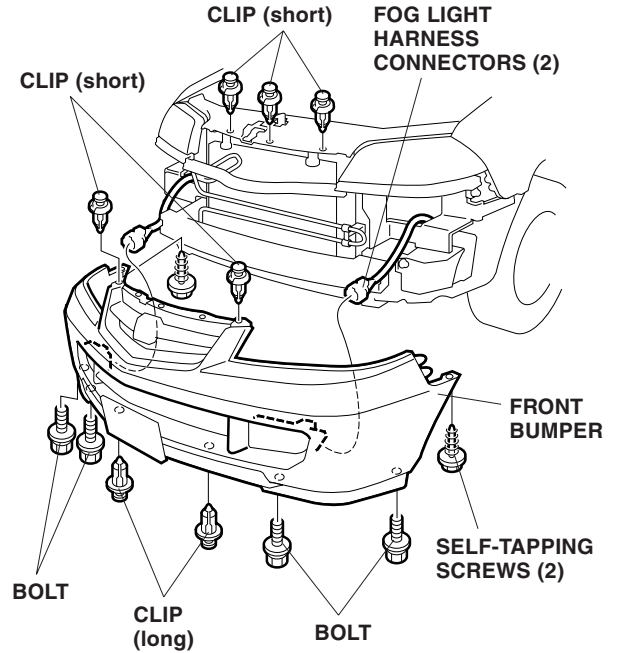

9. Pull the front bumper out toward you, then disconnect the fog light harness connectors. Remove the front bumper and rest it on a blanket.

10. Confirm the 10 scribed marks on the back of the front bumper
 - Note the location of the scribed marks.
11. Center-punch the 10 scribed marks. Using a drill and drill bits, drill a 9 mm hole through the front bumper at each of the 10 center-punched marks you just made.
 - Wear eye protection while drilling to prevent eye injury.
 - First drill with a 3 mm bit and finish with a 9 mm bit.
 - Remove all burrs from the edges of the holes with a file.

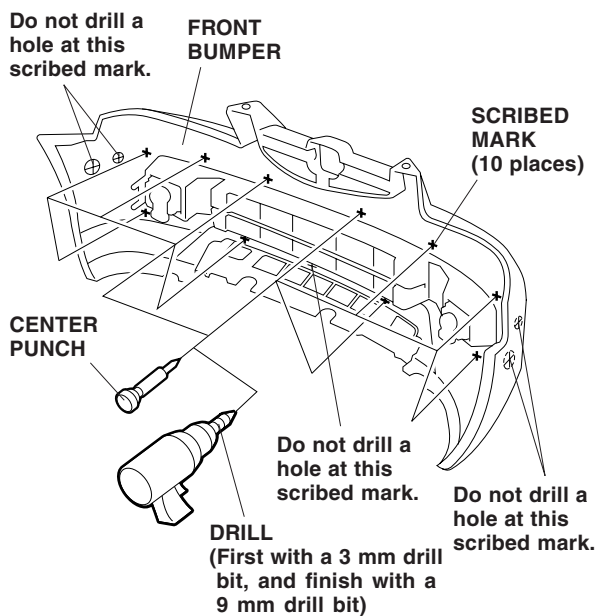

12. Attach the front lower trim to the front bumper with the 10 washers and 10 short screws.

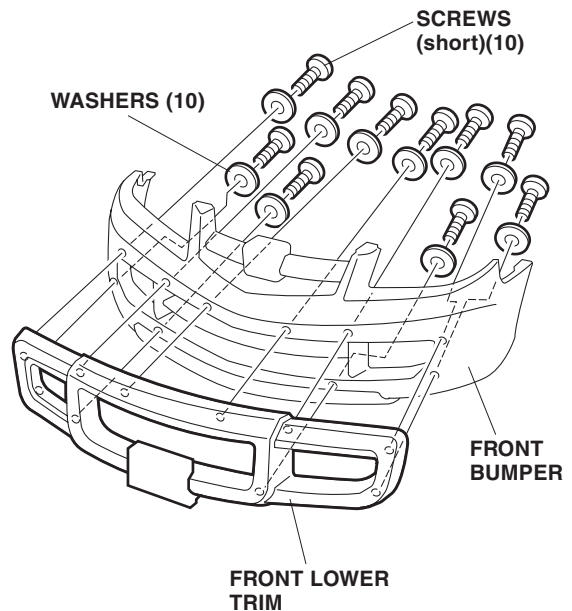

13. Reinstall the front bumper.
 - Check that all clips are installed securely without play or rattle.
14. Position the license plate frame on the license plate base and install the four washer-screws. Tighten the screws securely.

