



INSTALLATION INSTRUCTIONS

Accessory
**ATF AND POWER STEERING
FLUID COOLERS**

Application
2002 MDX

Publications No.
BII 23277-23652
Issue Date
FEB 2002

Revised February 22, 2002

PARTS LIST

**Power Steering Fluid Cooler (sold separately):
P/N 53765-S3V-800**

Power steering fluid cooler

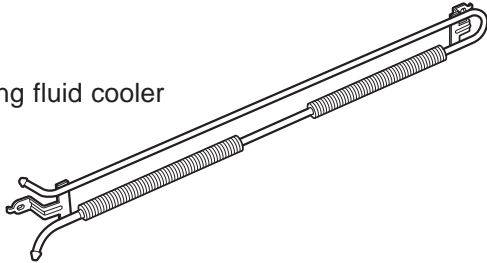

**ATF Cooler (sold separately):
P/N 06266-PGH-305**

ATF Cooler

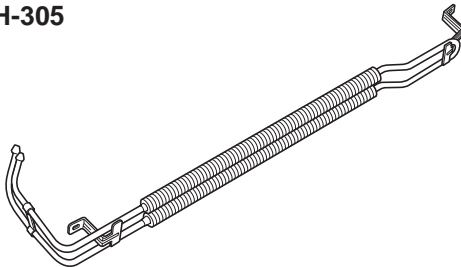

ATF Hose

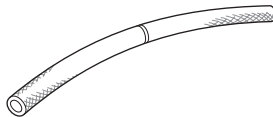

Hose spacer



2 Washer-bolts, 6 x 12 mm



3 Hose clamps



Rearview mirror hang-tag

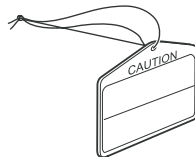

TOOLS AND SUPPLIES REQUIRED

- Phillips screwdriver
- Flat-tip screwdriver
- 10 mm Socket
- Ratchet
- 6" Extension
- Drain pan
- Pliers
- Blanket

INSTALLATION

Customer Information: The information in this installation instruction is intended for use only by skilled technicians who have the proper tools, equipment, and training to correctly and safely add equipment to your vehicle. These procedures should not be attempted by "do-it-yourselfers."

NOTE:

- Be careful not to damage the front bumper and other finished surfaces of the body. Rest the front bumper on a blanket during the installation.
 - Install the power steering fluid cooler before you install the ATF cooler.
- Open the hood, and remove the five clips that secure the top of the front bumper.

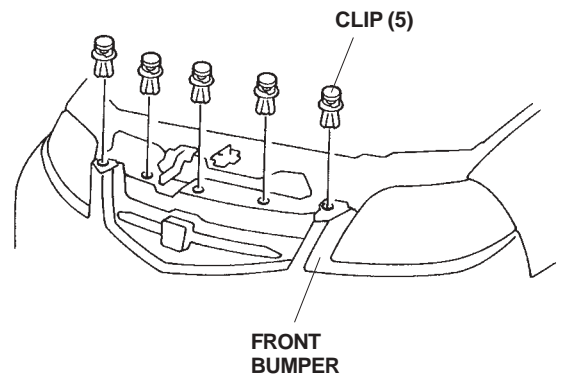

- Remove the two self-tapping screws, the two clips, and the four bolts that secure the front bumper.

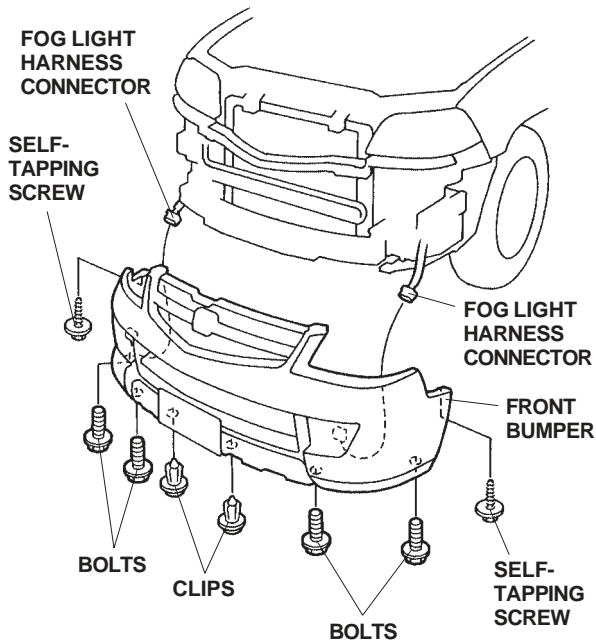

- Pull the front bumper out toward you, then disconnect the fog light harness connectors. Remove the front bumper, and rest it on a blanket.
- Remove the splash shield (13 clips).

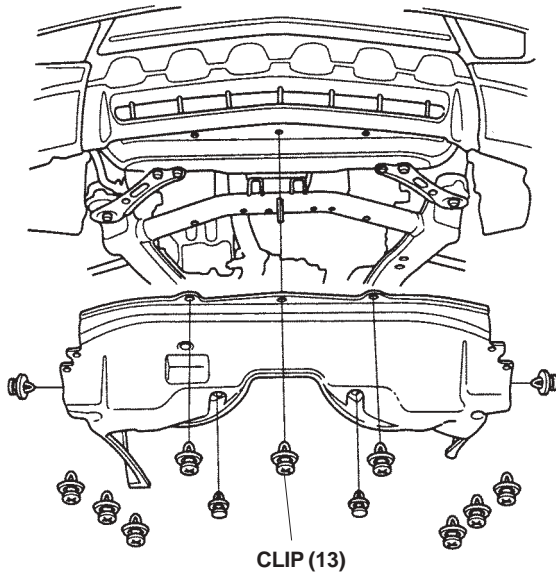

Installing the Power Steering Fluid Cooler

- Loosen the upper and lower hose clamps connected to the existing power steering fluid cooler.

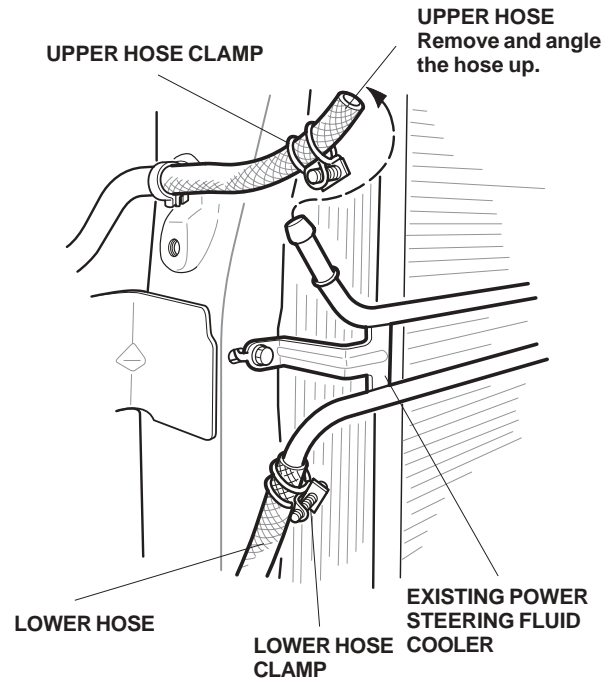

- With a drain pan under the vehicle, remove the upper (reservoir) hose from the cooler. Angle the hose up to prevent any excess fluid from leaking out.
- With an assistant holding the fluid cooler, remove the two bracket bolts, disconnect the lower hose, and remove the fluid cooler. Set the fluid cooler aside; it will not be reused.

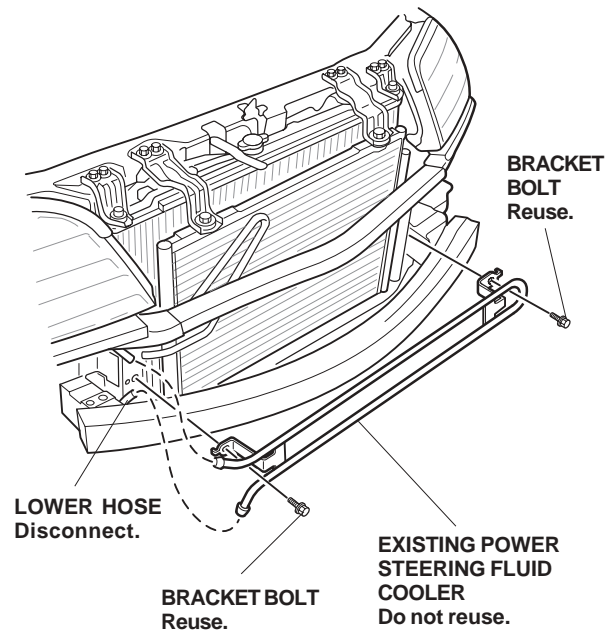

- Attach the lower hose to the new power steering fluid cooler, and fit the cooler into position on the front bulkhead. Reinstall the two bracket bolts, and tighten them securely.

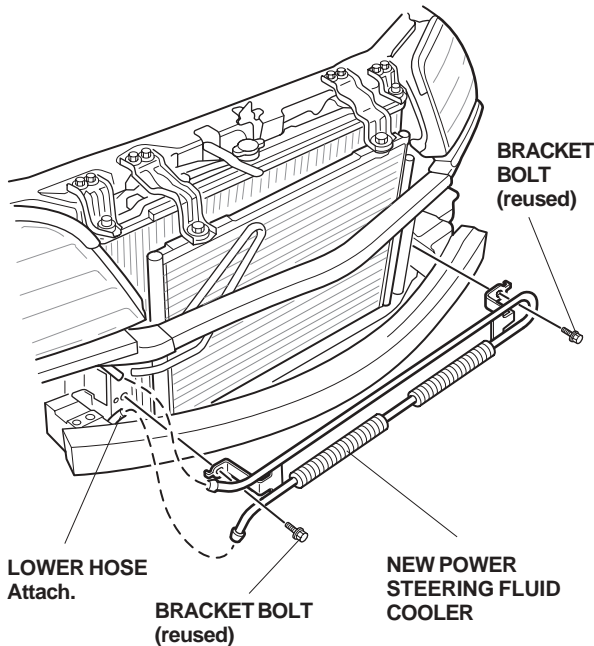

- Reinstall the upper hose. Make sure that the hose is pushed firmly against the stopper on the cooler and that the dot on the upper hose is facing forward. Tighten the upper hose clamp to the specification shown.

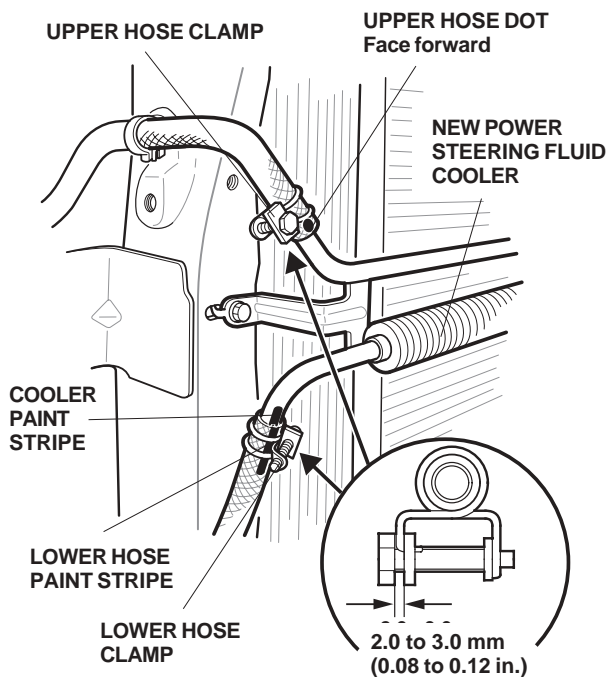

- Align the paint stripe on the lower hose with the paint stripe on the cooler, then tighten the lower hose clamp to the specification shown.

Installing the ATF Cooler

- Get the ATF hose and the ATF cooler. Attach the short end (from the white stripe) of the hose to the upper pipe with one new hose clamp from the kit.

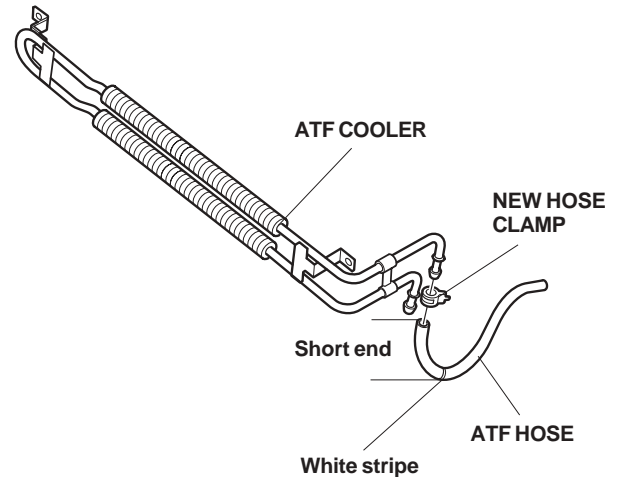

- Route the hose installed on the ATF cooler through the bulkhead, and fit the ATF cooler into position on the front bulkhead. Install the two 6 x 12 mm washer-bolts from the kit through the ATF cooler and into the threaded holes in the front bulkhead. Tighten the bolts securely.

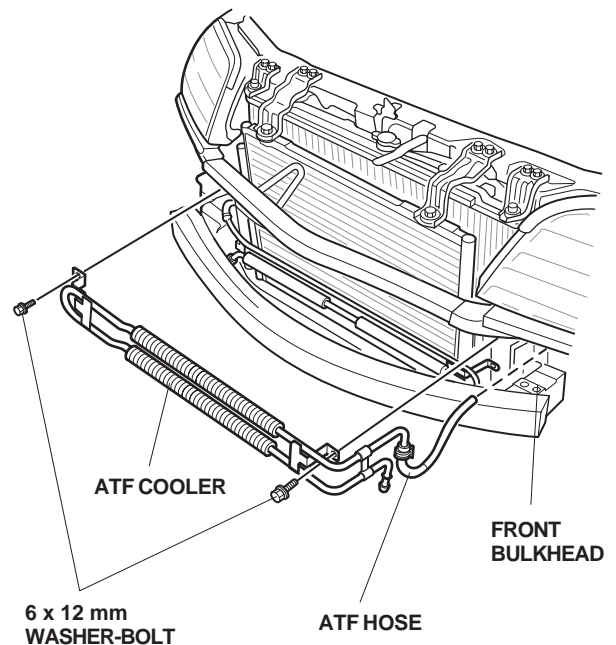

- Remove the ATF return hose from the transmission side, and attach the return hose to the lower ATF cooler pipe using one new hose clamp.

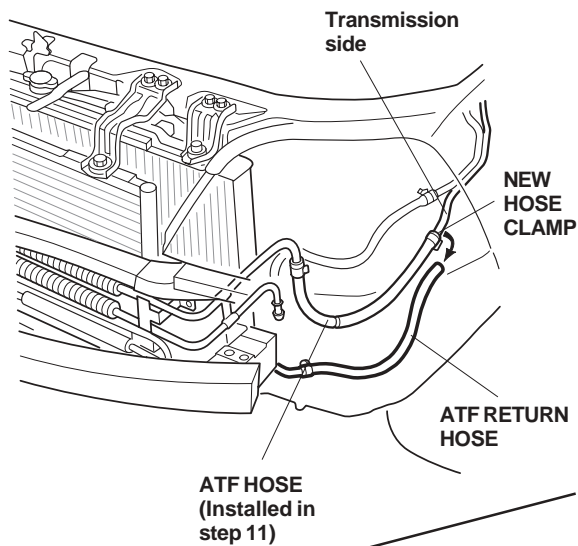

- Attach the ATF hose (installed in step 11) to the transmission side where you removed the return hose using one new hose clamp.

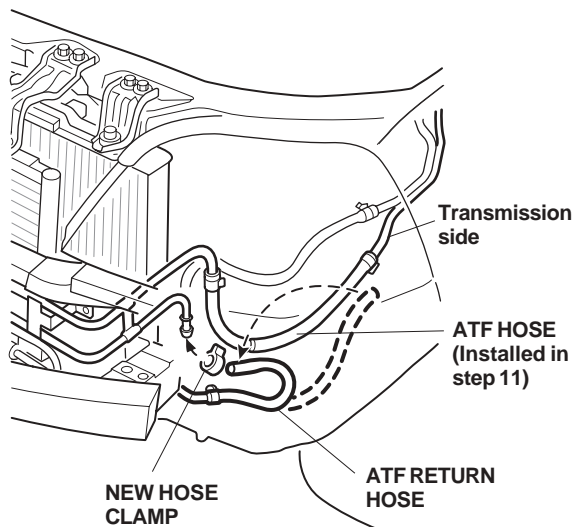

- Attach the hose spacer between the two hoses at the white line painted on the ATF hose.

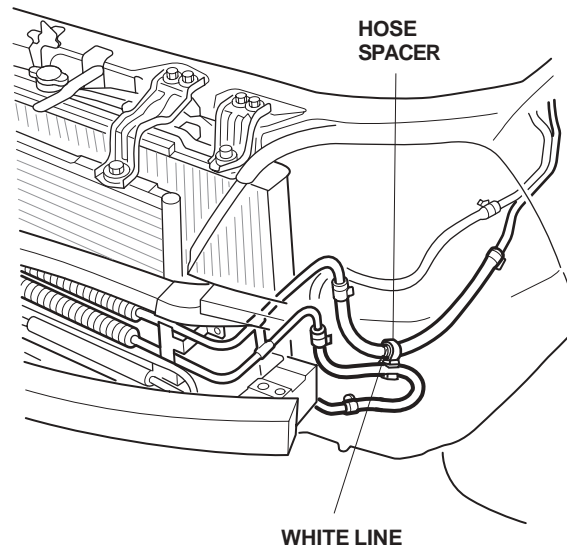

- Fill the power steering fluid to the Full level of the reservoir.
- Start the engine, and check for fluid leaks; repair as necessary.
- Check the ATF fluid level, and refill as necessary.
- With the engine turned off, turn the steering wheel all the way clockwise and all the way counterclockwise one time; then turn back to the straight-ahead position. Recheck the power steering fluid level, and refill as necessary.
- Perform an outside test drive of the vehicle involving vehicle turning, and lock to lock steering conditions. During the test drive, listen for any noise or any abnormal feeling in the steering. After the test drive, check the reservoir fluid level, and inspect for any fluid leaks. Refill as necessary.
- Reinstall the splash shield.
- Reinstall the front bumper. Make sure you plug in the fog light connectors.
- Place the ATF cooler hang-tag around the rearview mirror.