



INSTALLATION INSTRUCTIONS

Accessory
BACKUP SENSORS

Application
2015 TLX

Publications No.
VERSION 1
Issue Date
JULY 2014

PARTS LIST

Backup Sensors Attachment Kit
P/N 08V67-TZ3-200A

Control unit



Control unit bracket



Buzzer



Backup sensor harness

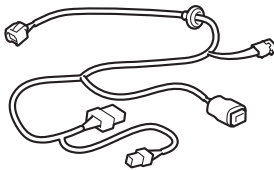

Subharness

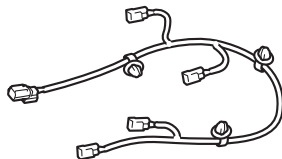

2 Corner sensor clips



6 Wire ties



4 Aluminum tapes



Fuse label



2 Flange bolts
(May not be used)



2 Urethane tapes



Wire tie with holder A



Wire tie with holder B



White center sensor clip



Black center sensor clip



Accessory user's information manual



**Backup Sensor Kit
P/N 08V67-TZ3-200K**

Right center sensor

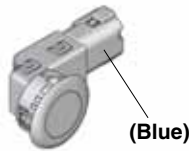

Left center sensor

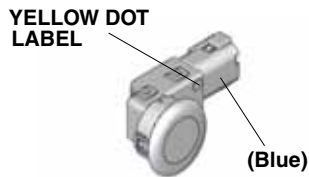

2 Corner sensors

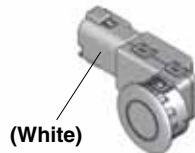

TOOLS AND SUPPLIES REQUIRED

- Phillips screwdriver
- 10 mm Open end wrench
- 10 mm Socket
- Pushpin
- Ratchet
- 3 mm Drill bit
- Eye protection (face shield, safety goggles, etc.)
- File
- Scissors
- Ruler
- Blanket
- Isopropyl alcohol
- Shop towel
- 24 mm and 26 mm Hole saws
- Drill
- Utility knife
- Diagonal cutters
- Masking tape
- Steel wire
- Tape

The following tool is available through the Honda Tool and Equipment Program. On the iN, click on: Service > Service Bay > Tool and Equipment Program, then enter the number under "Search." Or, call 888-424-6857.

- Trim Tool Set (T/N SOJATP2014)

Illustration of the Backup Sensors on the Vehicle

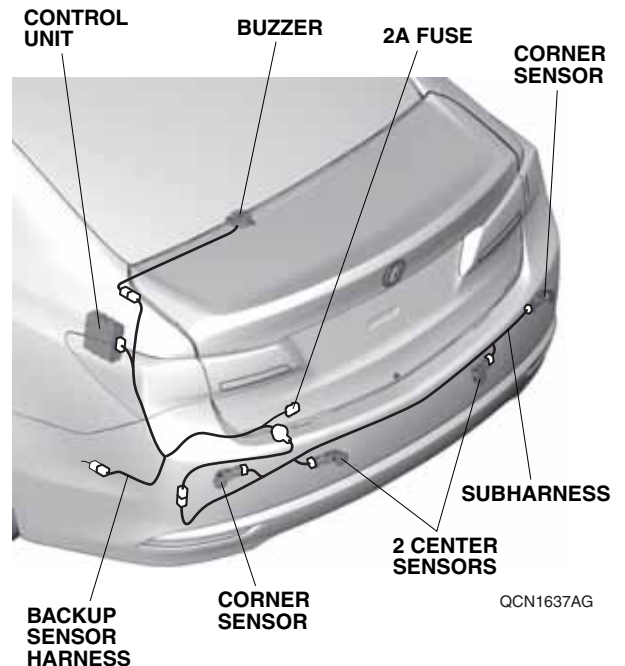

INSTALLATION

Client Information: The information in this installation instruction is intended for use only by skilled technicians who have the proper tools, equipment, and training to correctly and safely add equipment to your vehicle. These procedures should not be attempted by “do-it-yourselfers.”

NOTE: Refer to the 2015 TLX accessory Parts Information Bulletin (PIB) for the proper color sensors.

1. Open the trunk lid. Disconnect the negative cable from the battery.
2. Pull the two levers, and fold the both rear seat back forward.

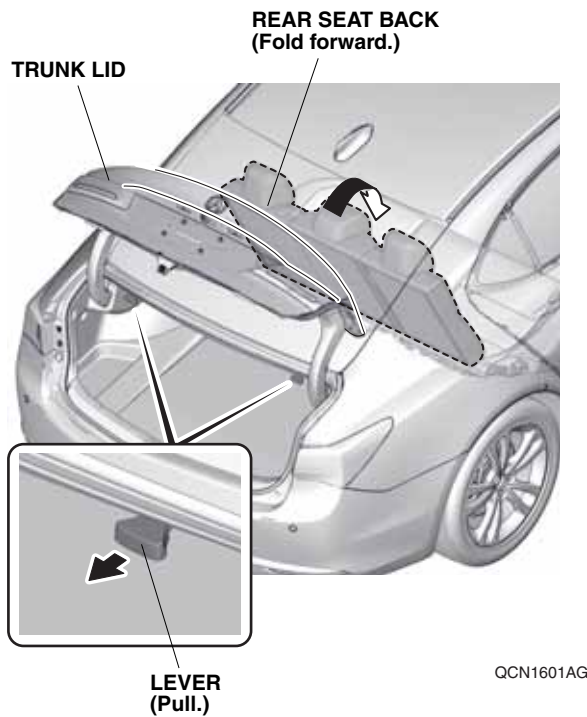

3. Pull back the weatherstrip, and remove the six clips from the trunk upper trim panel.

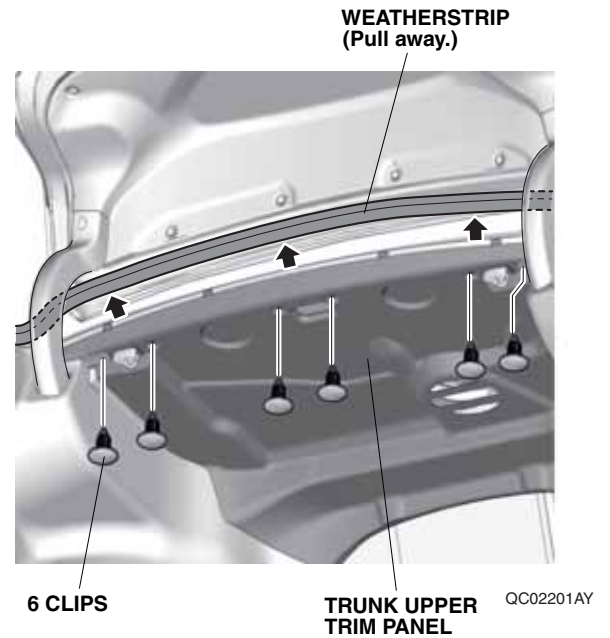

4. Remove the trunk floor lid.

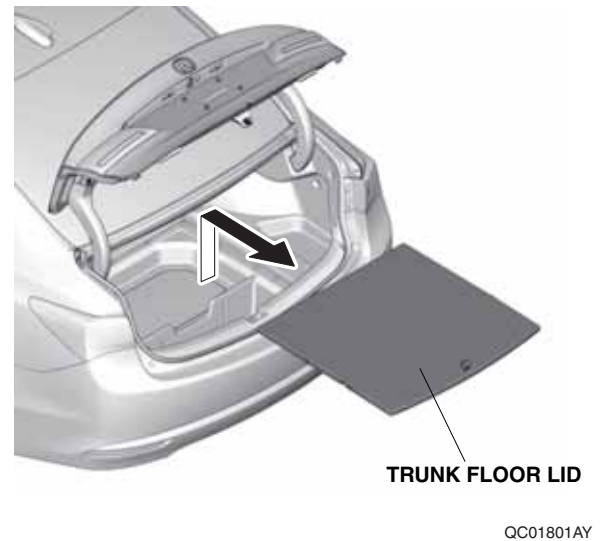

5. Remove the trunk rear trim panel.

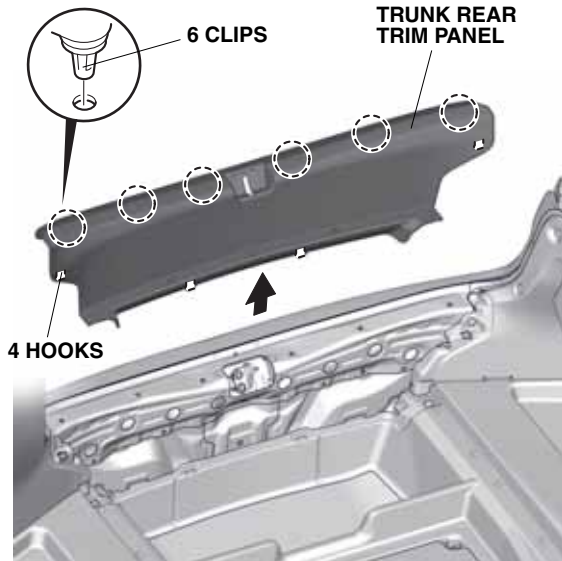

QCN1602AG

6. Remove the tool box.



TOOL BOX

QCN1603AG

7. Remove the trunk floor lining.

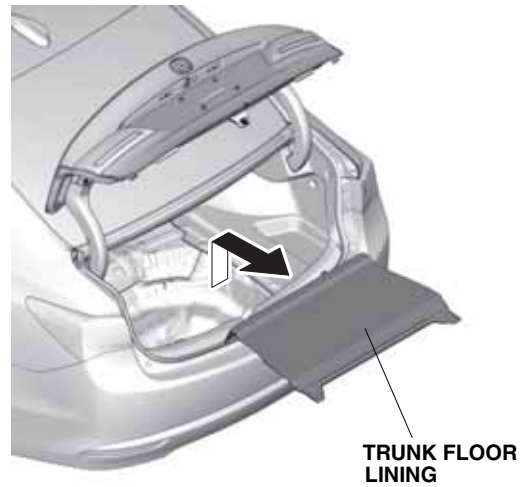

QCN1604AG

8. Pull back the weatherstrip. Remove the left trunk side trim panel.

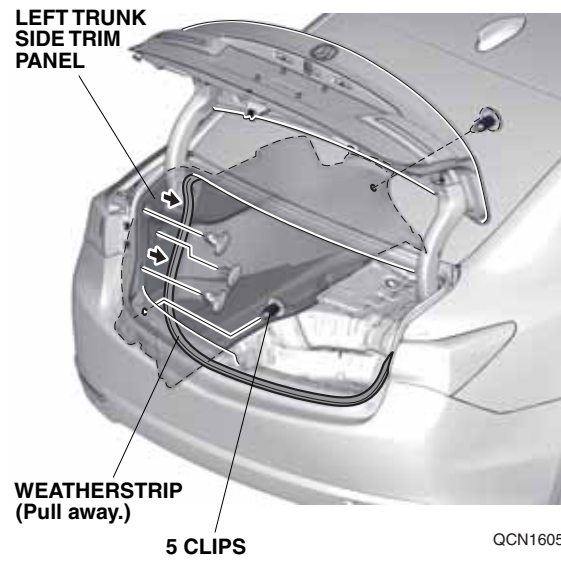

QCN1605BG

9. Remove the rear bumper.
 - On each side of the vehicle, attach masking tape to the rear bumper, taillight, and rear fender as shown.

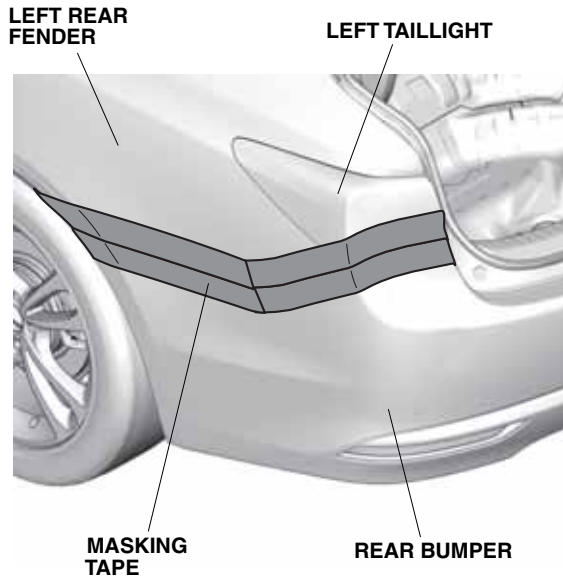

QCN1606AG

- Remove the two caps, two flange bolts, six self-tapping screws, and two clips.

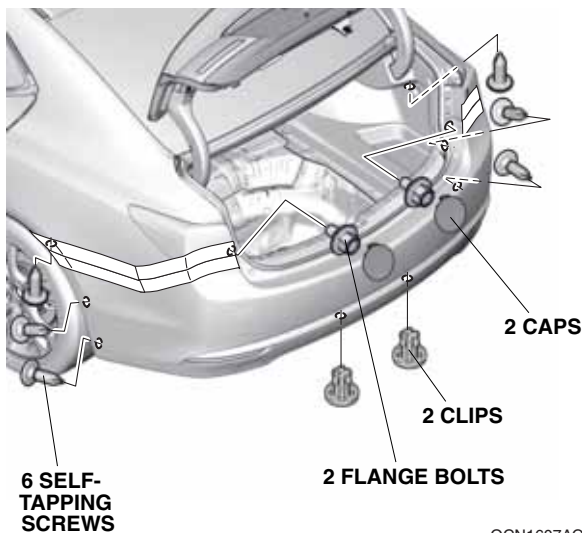

QCN1607AG

- Release the nine retaining tabs on each side of the bumper.

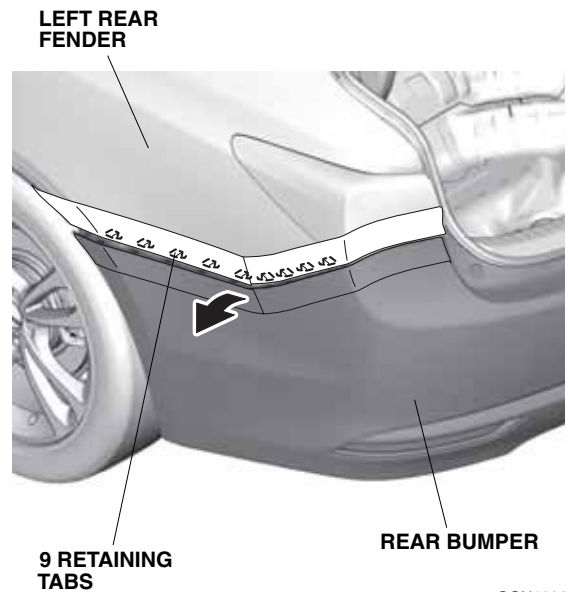

QCN1608AG

- Release the two retaining tabs on each side of the bumper.

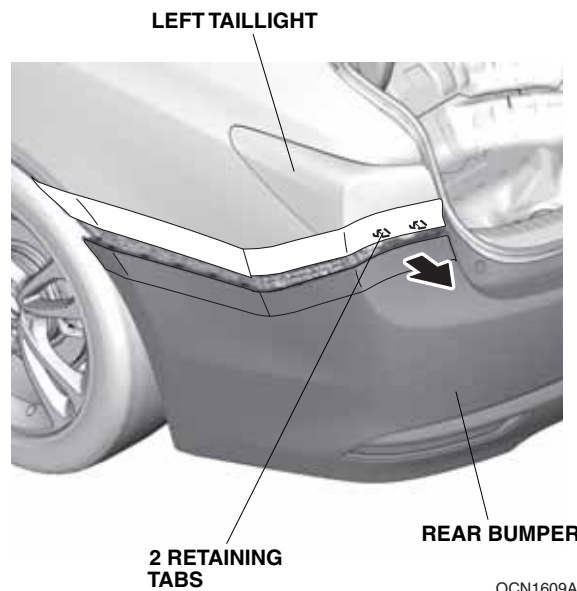

QCN1609AG

- With the help of an assistant, remove the rear bumper.
- Place the rear bumper on a blanket.

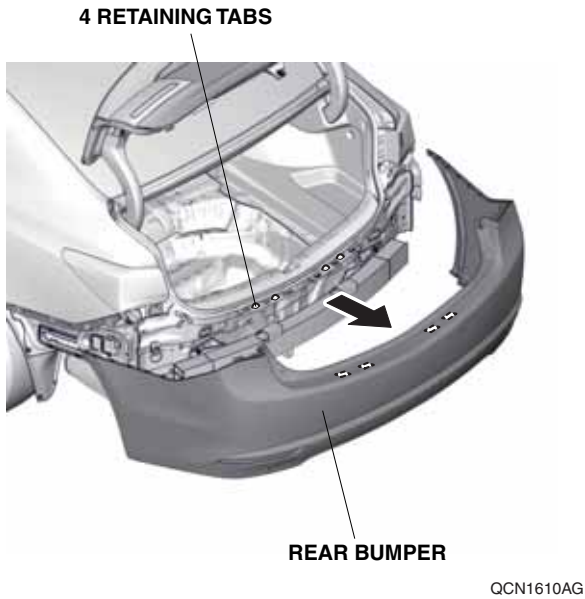

10. Mark the inside of the rear bumper:
- Locate the four scribe marks on the inside of the rear bumper at the center and left side.
 - Using a pushpin, pierce the rear bumper at the top and center of the two marks.
NOTE: There are several markings on the inside of the rear bumper. Before piercing the rear bumper, verify the locations.
NOTE: Make sure to pierce the scribe marks at a right angle to the rear bumper.

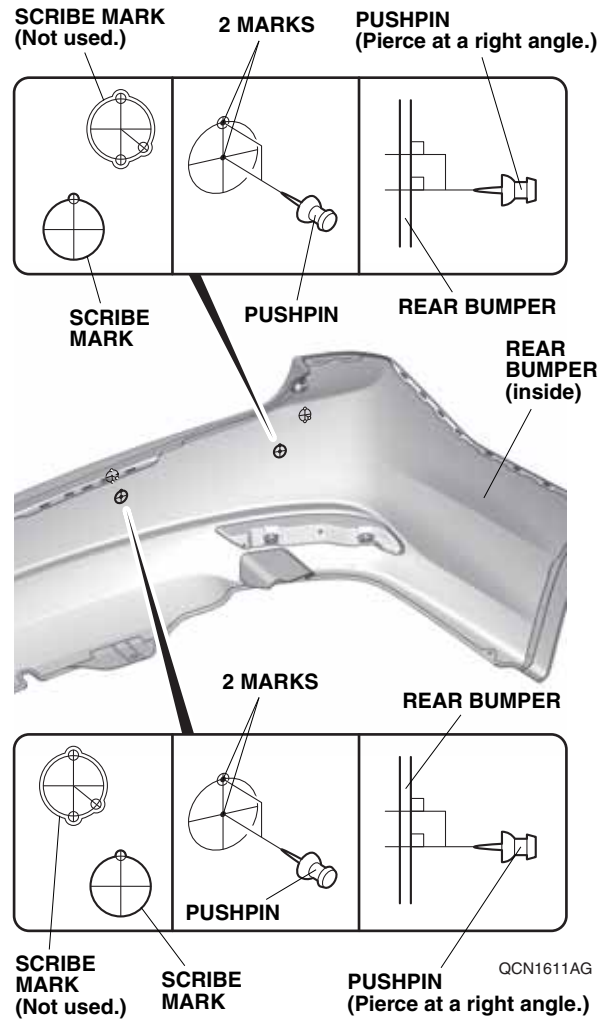

11. Mark the inside of the rear bumper:

- Locate the four scribe marks on the inside of the rear bumper at the center and right side.
- Using a pushpin, pierce the center scribe mark of rear bumper at the top and center of the two marks.
- Using a pushpin, pierce the right scribe mark of rear bumper at the bottom and center of the two marks.

NOTE: There are several markings on the inside of the rear bumper. Before piercing the rear bumper, verify you have the correct locations.

NOTE: Make sure to pierce the scribe marks at a right angle to the rear bumper.

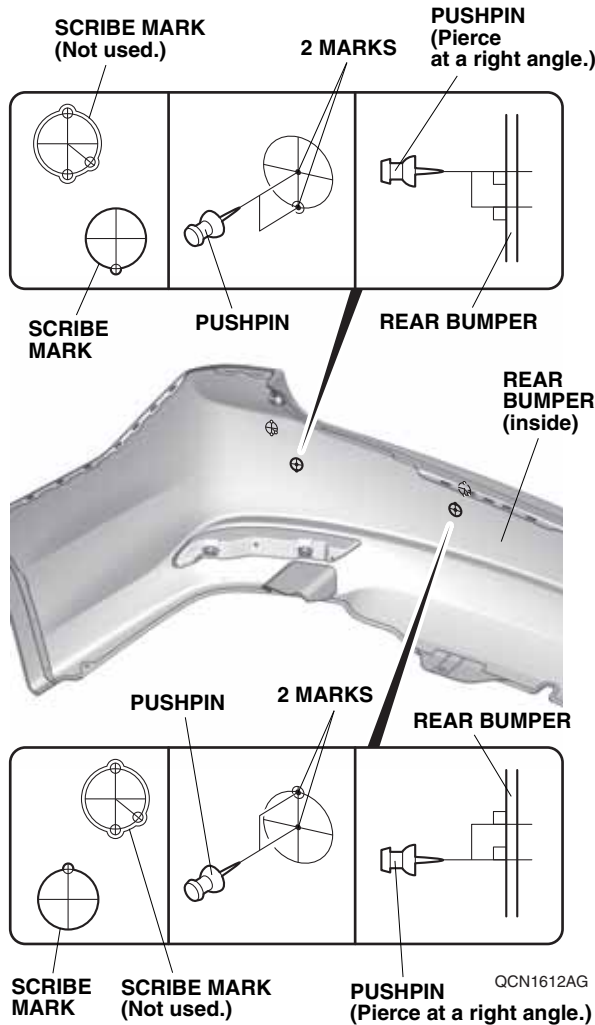

12. While wearing eye protection, drill all eight pierced marks.
NOTE: Make sure to drill at a right angle to the rear bumper.

- Using a 3 mm drill bit, drill each pierced marks from the outside of the rear bumper.

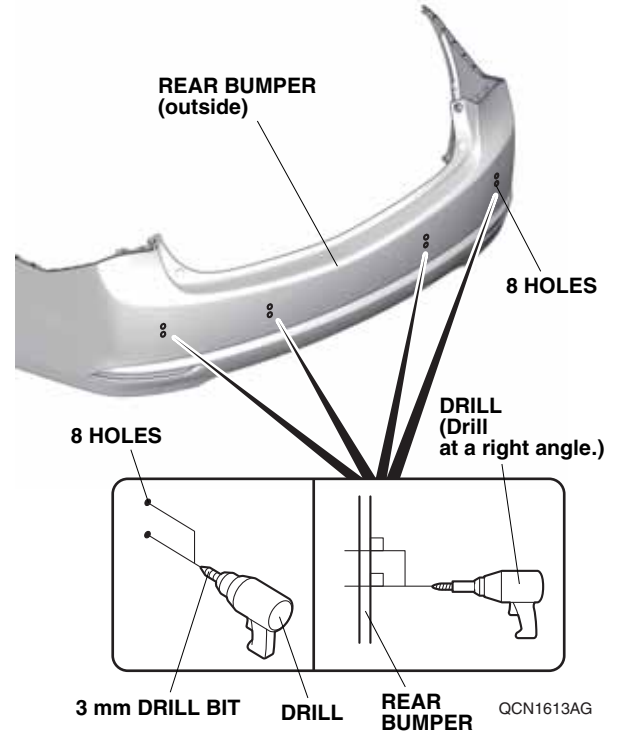

- Using a 24 mm hole saw, enlarge the outboard (left and right corner sensor) bumper holes by drilling the 3 mm holes. Make sure to drill the left outboard lower hole and right outboard upper hole. Remove any burrs.

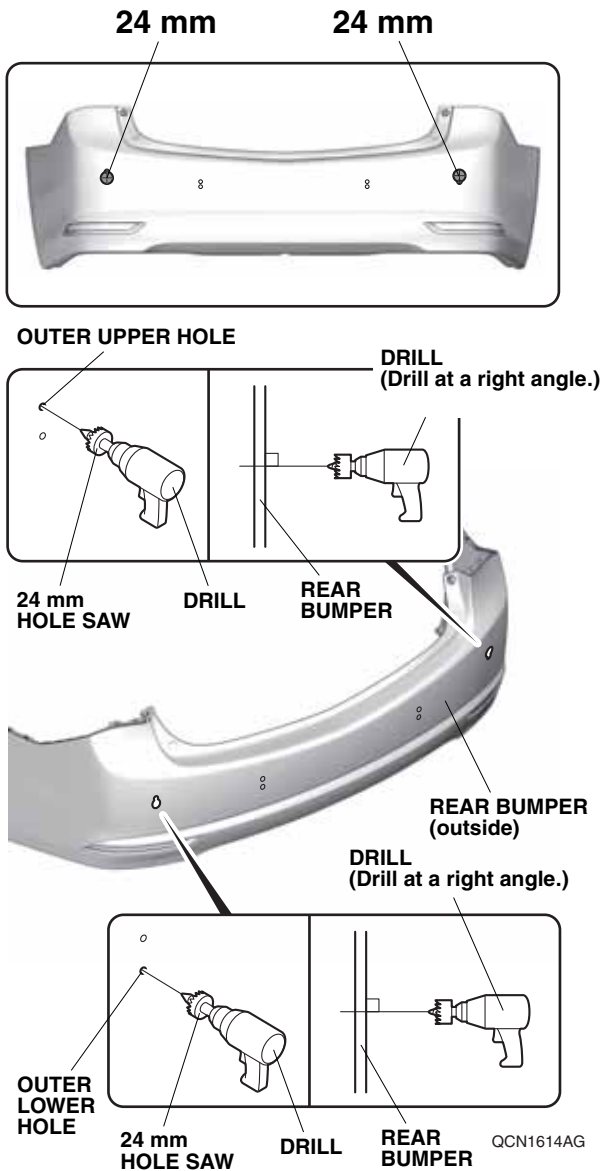

- Using a 26 mm hole saw, enlarge the inboard (center sensor) bumper holes by drilling the lower 3 mm holes. Remove any burrs.

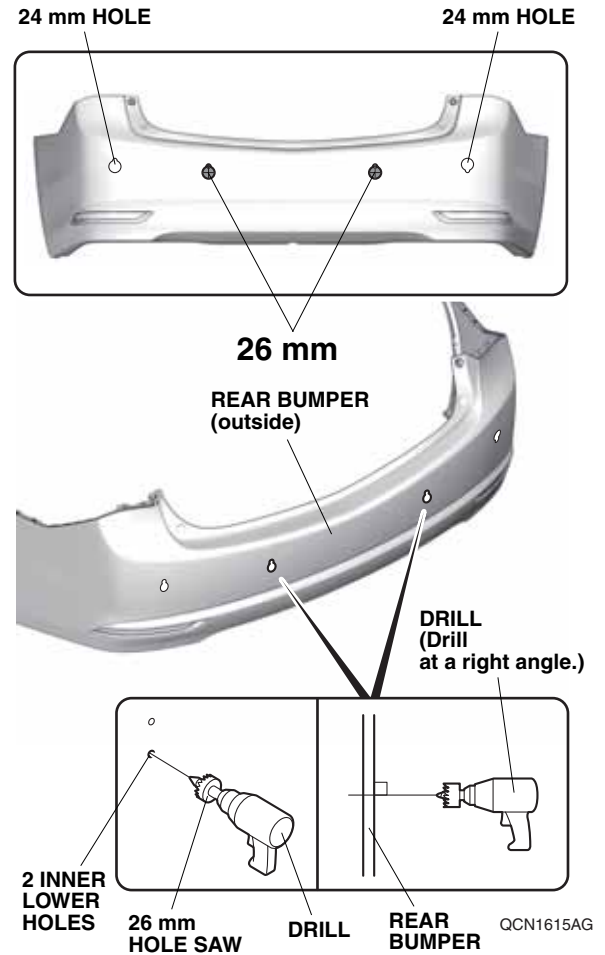

13. Using the sensor clips, install the left and right center sensors (blue) into the 26 mm holes in the rear bumper. Use the black clip on the left center sensor, and the white clip on the right center sensor. Note the direction and the pin location for each sensor.

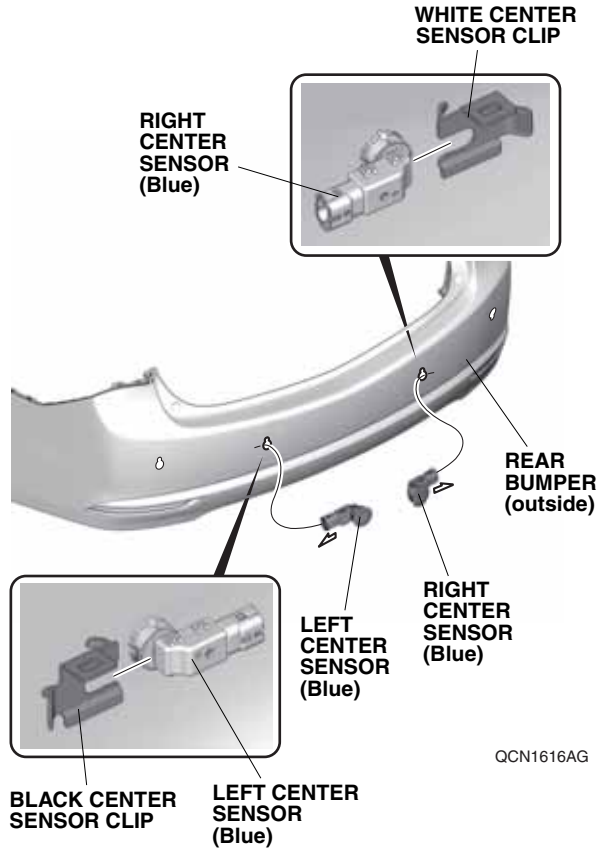

14. Using the sensor clips, install the two corner sensors (white) into the 24 mm holes in the rear bumper. Note the direction and the pin location for each sensor.

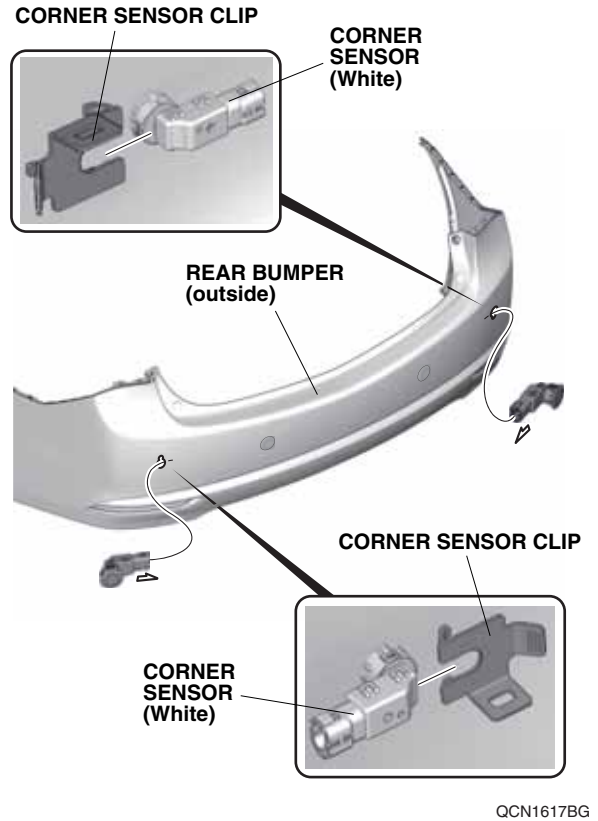

15. Plug the four subharness 2-pin connectors into the two center sensors (Blue) and the two corner sensors (White).

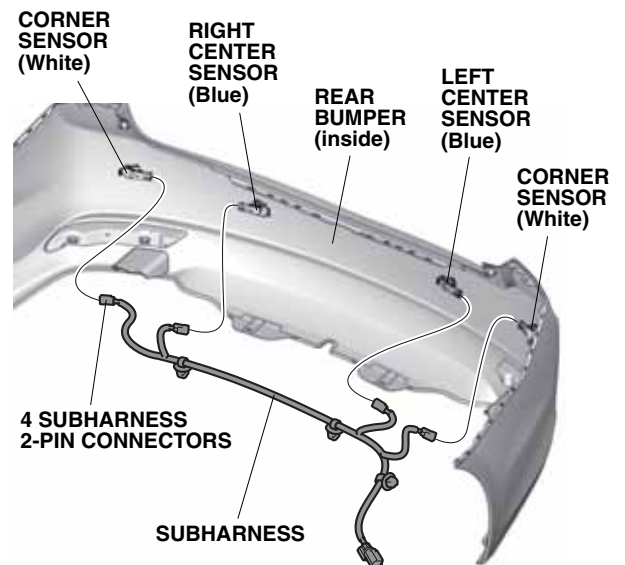

16. Secure the three subharness clips to the two center sensor clips and the corner sensor clip as shown.

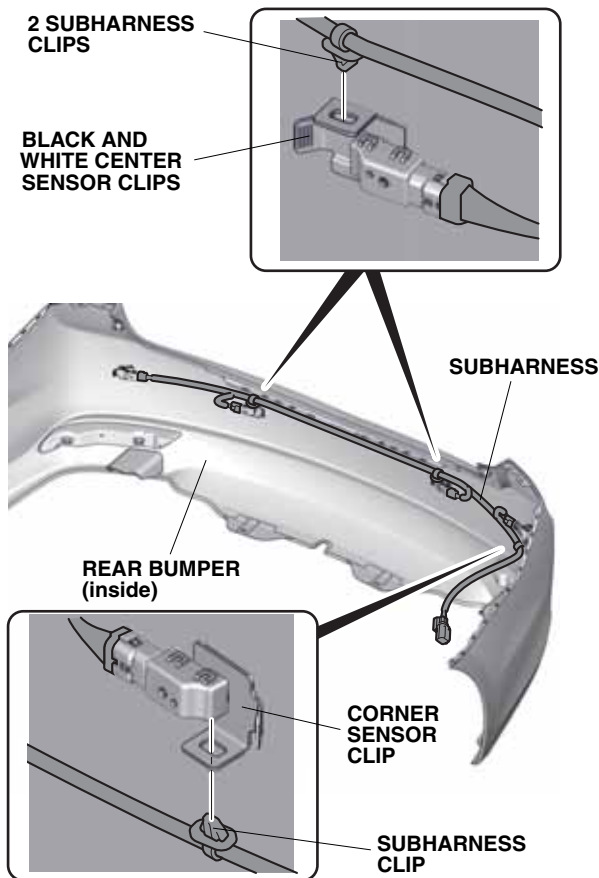

QC1619AG

17. Using isopropyl alcohol on a shop towel, thoroughly clean the rear bumper where the aluminum tapes will attach.

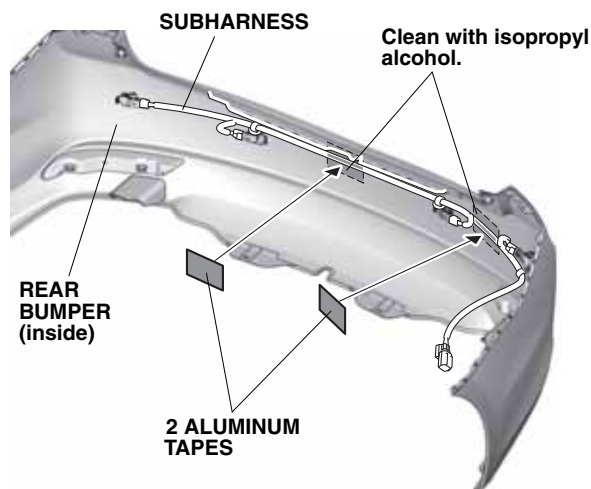

QC1620AG

18. Secure the subharness to the rear bumper with the two aluminum tapes.

19. Wrap one piece of urethane tape around the buzzer harness at the measurement shown.

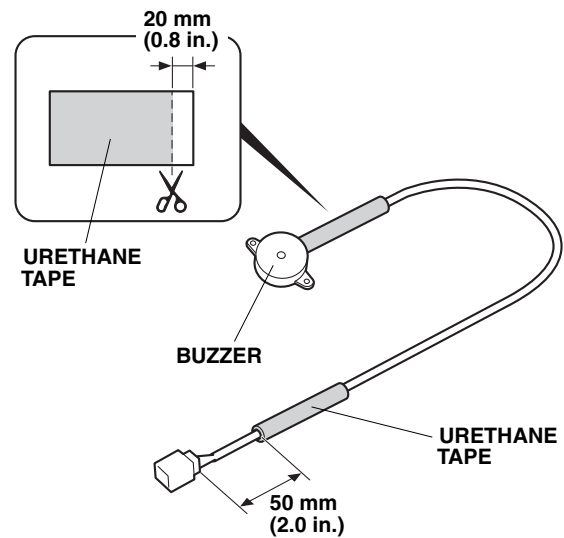

QC1621AG

20. Using scissors, cut the other piece of urethane tape at the measurement shown. Wrap the cut urethane tape around the buzzer harness as shown.

21. Route a piece of steel wire through the trunk area as shown.

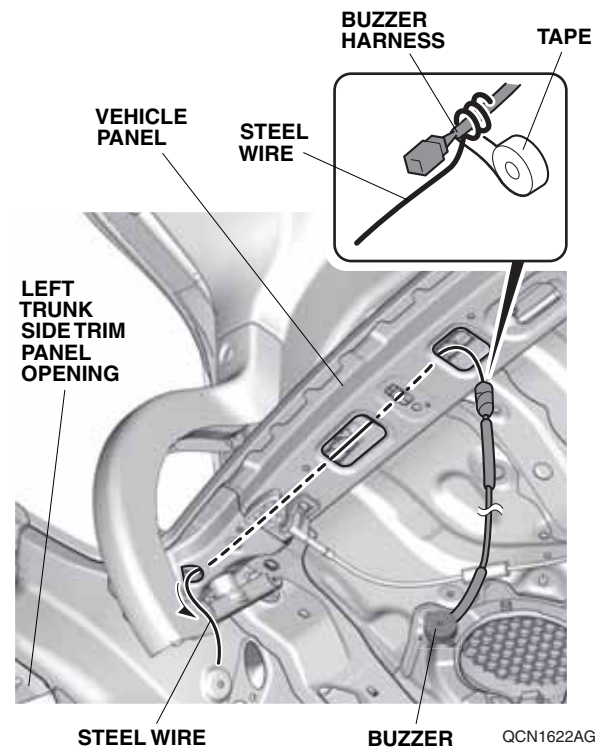

QC1622AG

22. Attach the connector end of the buzzer harness to the steel wire using tape.

23. Gently pull the steel wire to route the harness through the trunk area. Remove the tape and the steel wire.

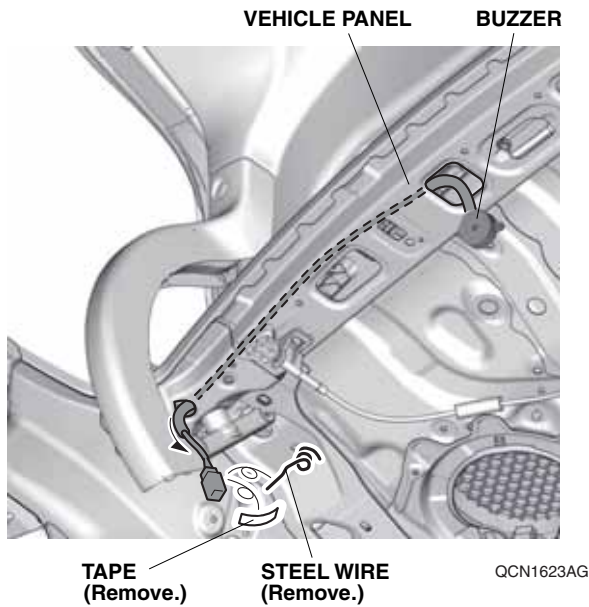

24. Using isopropyl alcohol on a shop towel, thoroughly clean the vehicle panel where the buzzer will attach.

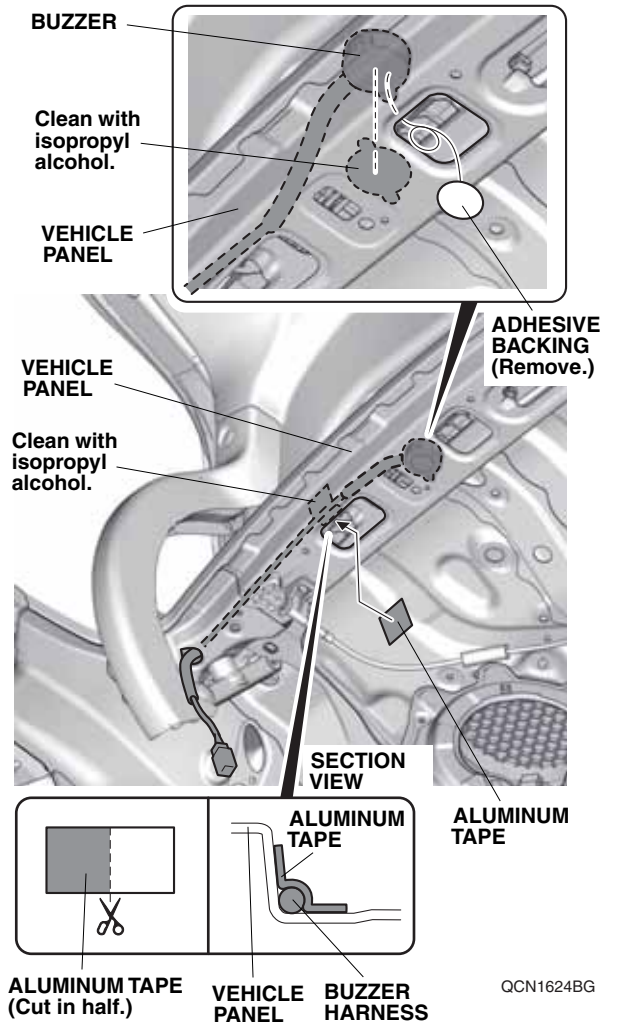

25. Remove the adhesive backing from the buzzer and attach it to the vehicle panel.
NOTE: Make sure the buzzer is attached in the correct position. Do not cover the installation holes.
26. Using scissors, cut one aluminum tape in half, and secure the buzzer harness to the vehicle panel with a cut piece of aluminum tape as shown.

27. Using an utility knife, remove the area of the trunk upper trim panel as shown.

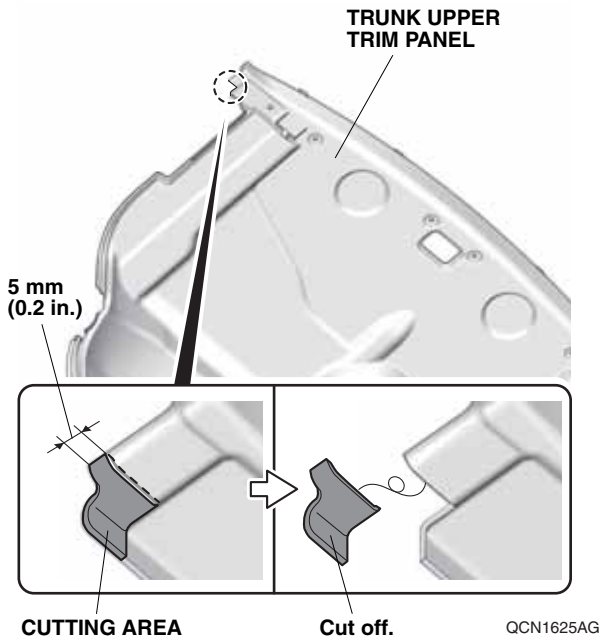

28. Using isopropyl alcohol on a shop towel, thoroughly clean the fuse case where the fuse label will attach. Attach 2A fuse label to the fuse case.

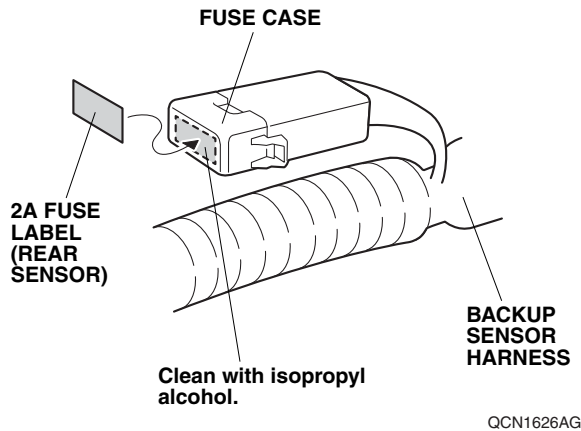

29. Install the control unit bracket on the control unit.

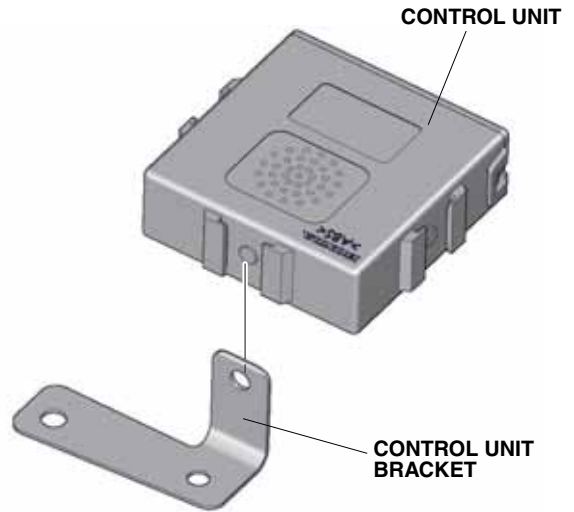

If the vehicle is equipped with a vehicle unit, go to step 30; if not, go to step 31.

With vehicle unit

30. Remove the two vehicle bolts from the vehicle unit. Secure the control unit to the vehicle panel with the two vehicle bolts just removed. Go to step 32.

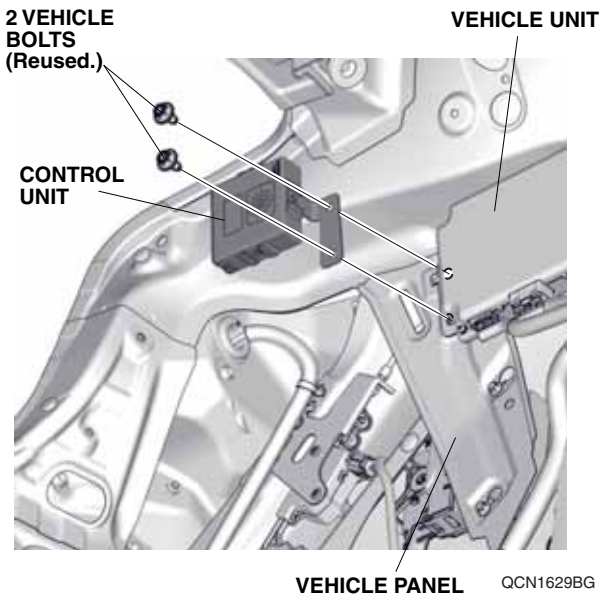

Without vehicle unit

31. Secure the control unit to the vehicle panel with the two flange bolts.

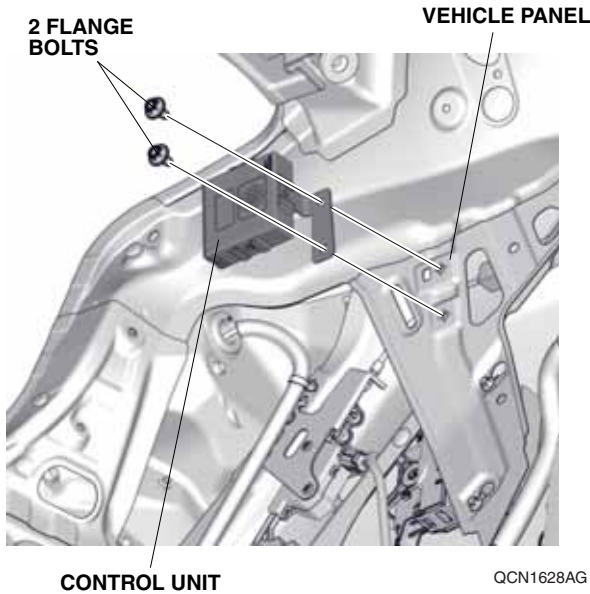

32. Plug the backup sensor harness 14-pin connector into the control unit.

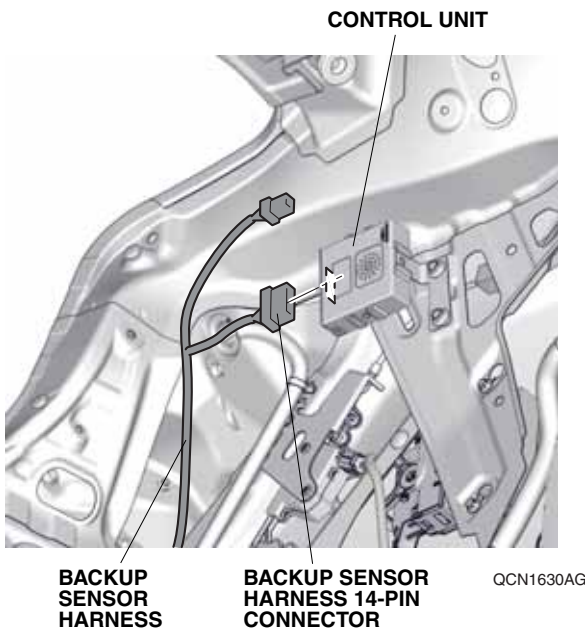

33. Route the backup sensor harness along the vehicle harness.

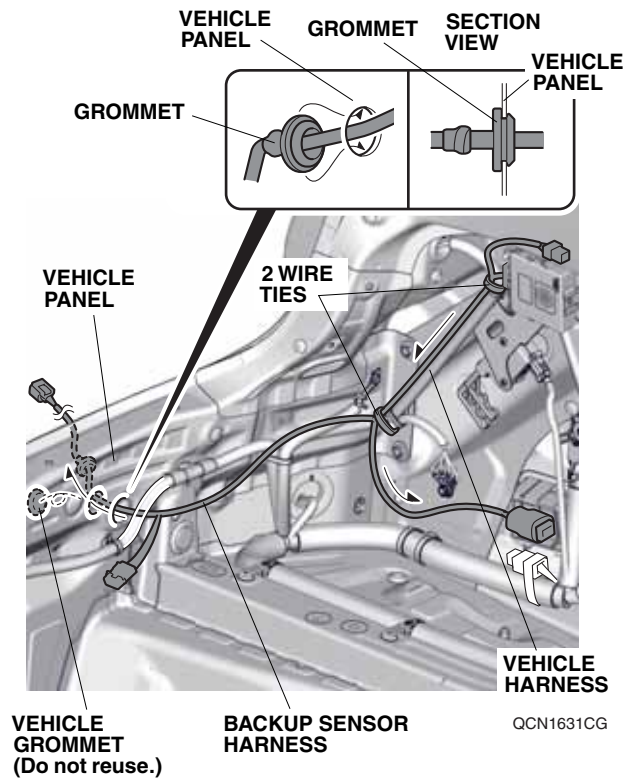

34. Locate and remove the vehicle grommet from the vehicle panel.
35. Route the backup sensor harness through the hole, and seat the grommet on the backup sensor harness in the vehicle panel hole.
NOTE: Do not pull on the backup sensor harness when installing the grommet.
36. Secure the backup sensor harness to the vehicle harness with two wire ties.

37. Release the vehicle harness 2-pin connector, and remove the dummy connector from the vehicle 2-pin connector.

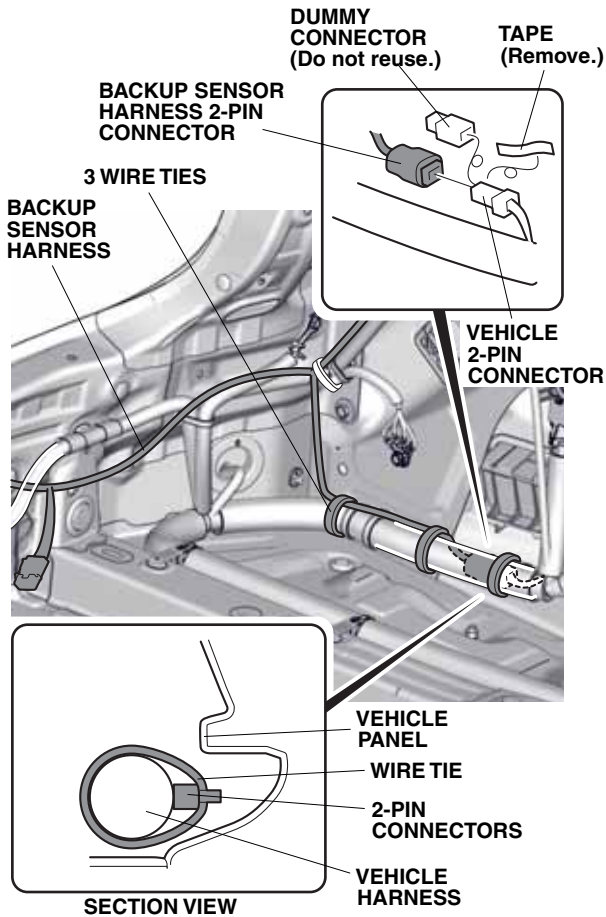

QCN1633CG

38. Plug the backup sensor harness 2-pin connector into the vehicle 2-pin connector. Secure the 2-pin connectors and backup sensor harness to the vehicle harness with three wire ties as shown.

39. Secure the fuse case to the vehicle harness with the wire tie with holder A.

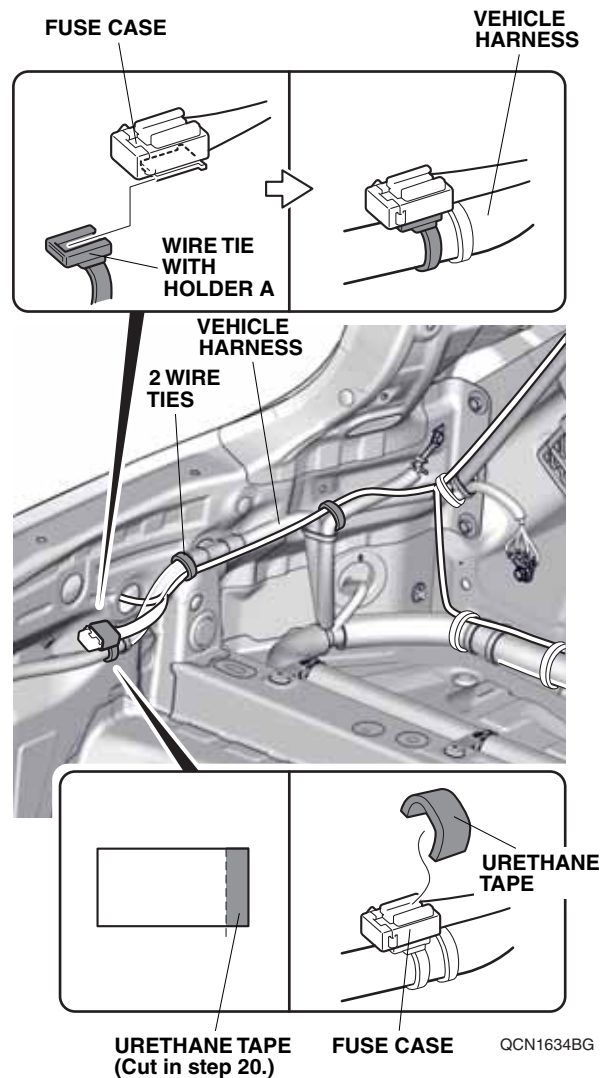

QCN1634BG

40. Using isopropyl alcohol on a shop towel, thoroughly clean the fuse case where the urethane tape will attach. Attach the urethane tape cut in step 20 on the fuse case as shown.
41. Secure the backup sensor harness to the vehicle harness with two wire ties.

42. Plug the backup sensor harness 2-pin connector into the buzzer harness 2-pin connector.

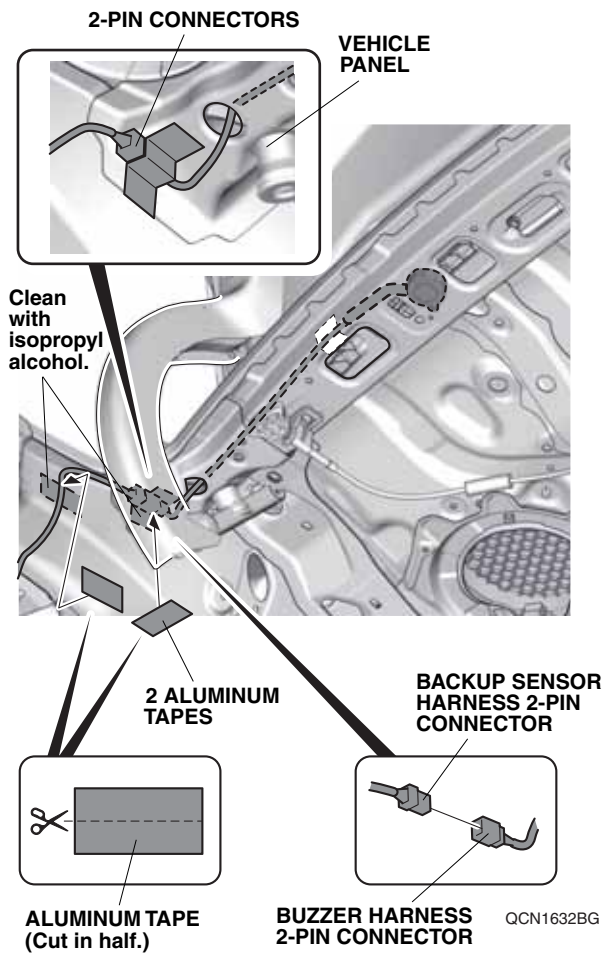

43. Using isopropyl alcohol on a shop towel, thoroughly clean the vehicle panel where the aluminum tapes will attach.
44. Using scissors, cut one aluminum tape in half. Secure the 2-pin connectors and the buzzer harness to the vehicle panel with the two cut pieces of aluminum tape.

45. Secure the backup sensor harness 8-pin connector to the vehicle harness with the wire tie with holder B.

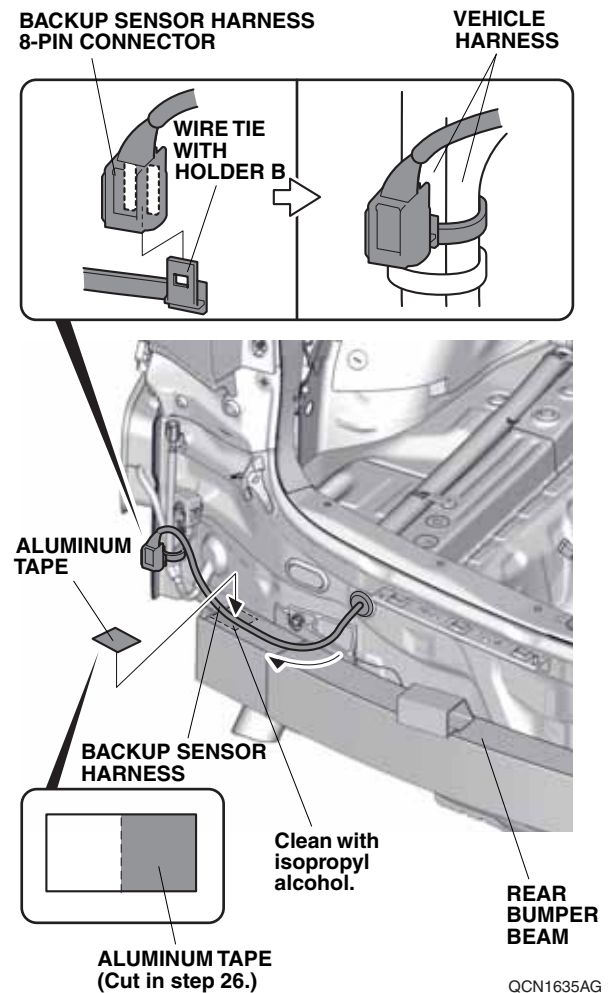

46. Using isopropyl alcohol on a shop towel, thoroughly clean the rear bumper beam where the aluminum tape will attach.
47. Secure the backup sensor harness to the rear bumper beam with one piece of aluminum tape cut in step 26.

48. With the help of an assistant, bring the rear bumper next to the rear of the vehicle, plug the subharness 8-pin connector into the backup sensor harness 8-pin connector, and reinstall the rear bumper.

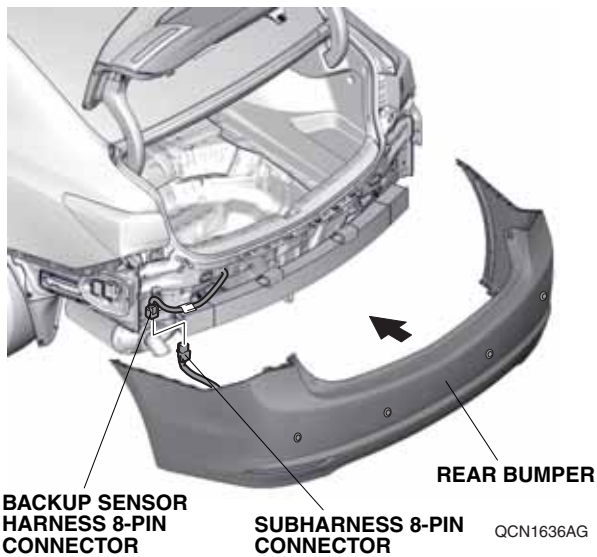

49. Check that all wire harnesses are routed properly and that all connectors are plugged in.
50. Reinstall all removed parts.
51. Reconnect the negative cable to the battery.
52. Press and hold the radio power button for two seconds to restore the radio and navi (if equipped) system functions.
53. Reset the clock on vehicles without navigation.

Check the Operation of the Backup Sensors

54. Make sure that the backup sensors work properly as described in the Accessory User's Information Manual supplied with the backup sensor kit.

Adjust the Volume Control

The factory setting is maximum volume. If the customer wants the volume adjusted, turn the control knob as shown using a small flat-tip. Do not force the adjuster as it could damage the unit.

