



INSTALLATION INSTRUCTIONS

Accessory
CARGO LINER
P/N 08P42-TL7-200

Application
**2013 TSX
SPORT WAGON**

Publications No.
BII 13475
Issue Date
SEP 2012

PARTS LIST

Cargo liner

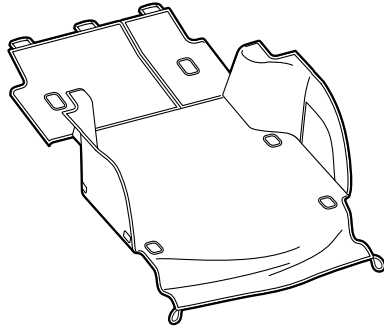

Bag

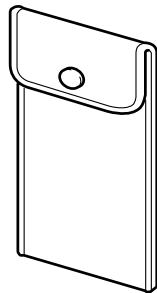
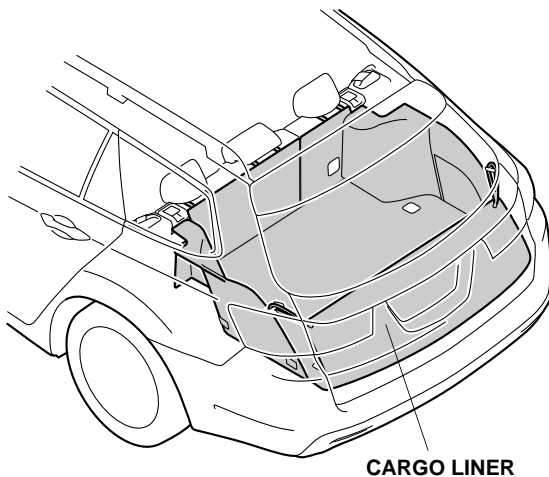

Illustration of the Cargo Liner in the Vehicle



INSTALLATION

NOTE:

- Do not damage the vehicle during installation.
- Store the cargo liner in the bag for safe-keeping when not being used.

Removing the Vehicle Parts

1. Open the tailgate. Remove the tonneau cover from the vehicle.

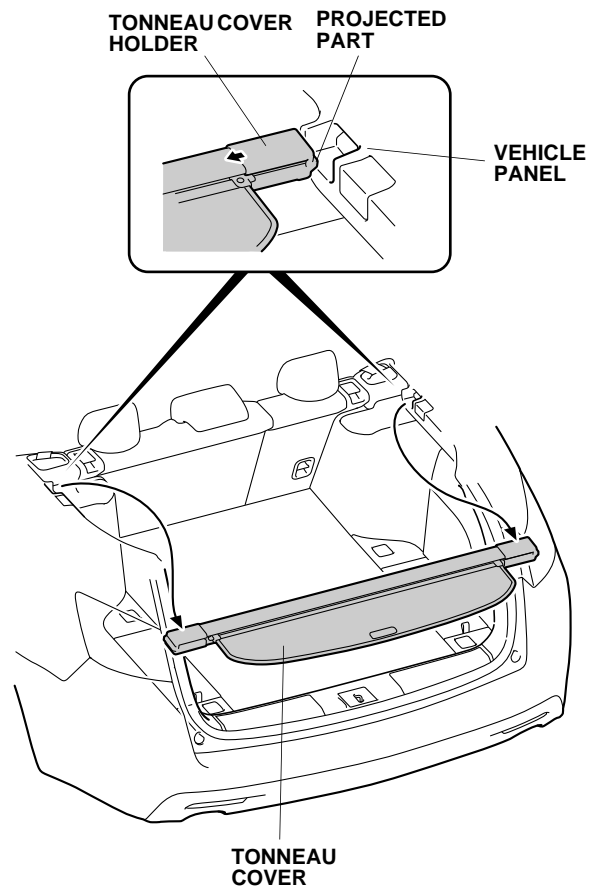

Installing the Cargo Liner

2. Remove three headrests from the left rear seat and right rear seat.

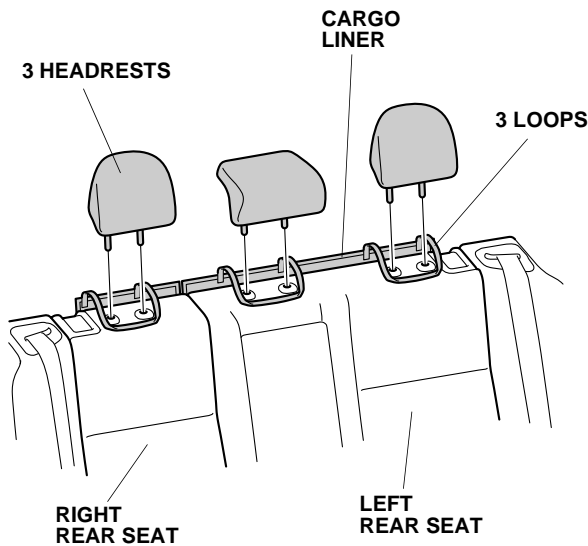

3. Place three loops on the cargo liner over the seats, and secure by reinstalling the headrests. Make sure the headrests are facing the correct direction.
4. Lift the cargo floor. Secure two pockets on the cargo liner to the cargo floor as shown.

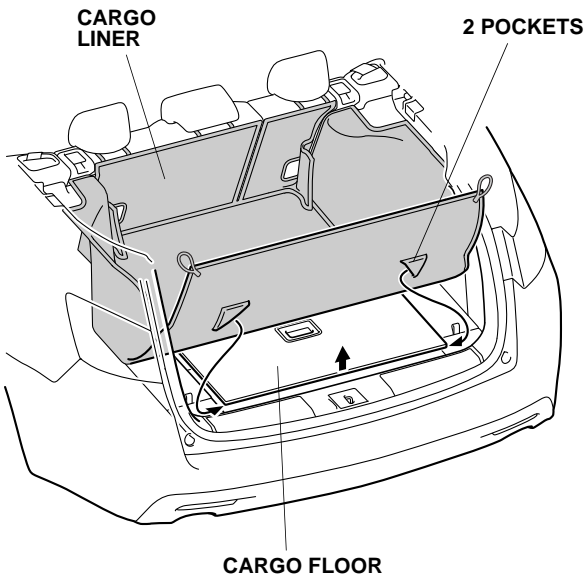

5. Insert two tabs on the cargo liner between the left side trim.

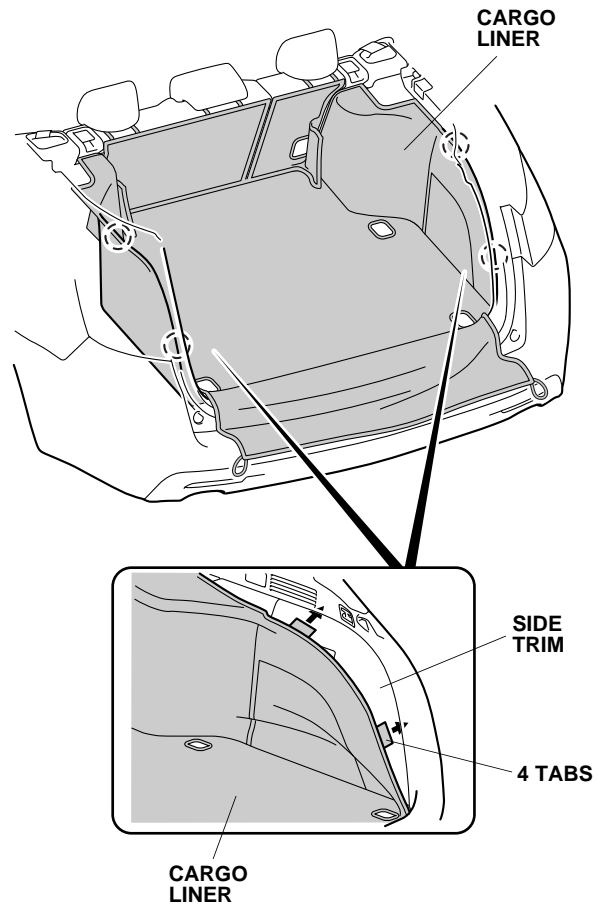

6. Repeat the same procedure on the other side of the vehicle.

7. Fold down the rear seats.

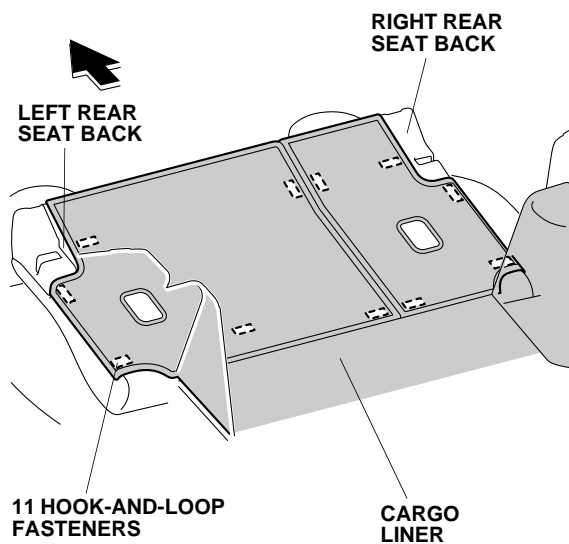

8. Secure eleven hook-and-loop fasteners on the cargo liner to the left rear seat back and right rear seat back.
9. Secure twenty hook-and-loop fasteners (10 on each side) on the cargo liner to the cargo area as shown.

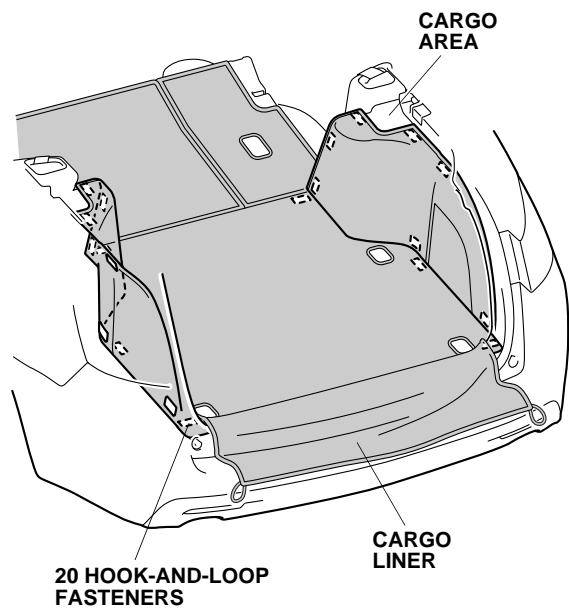

10. Secure two loops on the cargo liner to two hooks.

