



INSTALLATION INSTRUCTIONS

Accessory
TRUNK DRAWER

Application
2012 TL

Publications No.
BII 45426
Issue Date
MAR 2011

PARTS LIST

Trunk drawer tray

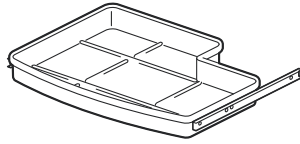

Right trunk drawer rail

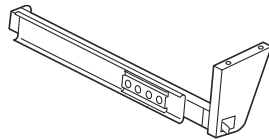

Left trunk drawer rail

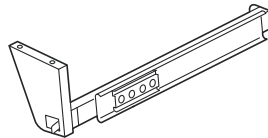

4 Rivet nuts, 6 mm



4 Washer screws



4 Plain washers



TOOLS AND SUPPLIES REQUIRED

Phillips screwdriver

Torque wrench

Ratchet

12 mm Socket

Center punch

Drill

3 mm, 6 mm, and 10 mm Drill bits

File

Scale

Electrical tape

Eye protection (face shield, safety goggles, etc.)

Utility knife

Rivet Nut Tool (P/N 07AAE-000A100)

Hex wrench

19 mm Wrench

Blanket

Touch-up paint

Plastic Trim Tool (T/N SILTRIMTL10)

INSTALLATION

Client Information: The information in this installation instruction is intended for use only by skilled technicians who have the proper tools, equipment, and training to correctly and safely add equipment to your vehicle. These procedures should not be attempted by "do-it-yourselfers."

NOTE: The trunk drawer cannot be used if the vehicle is equipped with an optional cargo hook.

Installing the Trunk Drawer

1. Open the trunk lid. Pull down the trunk upper trim panel (four clips).

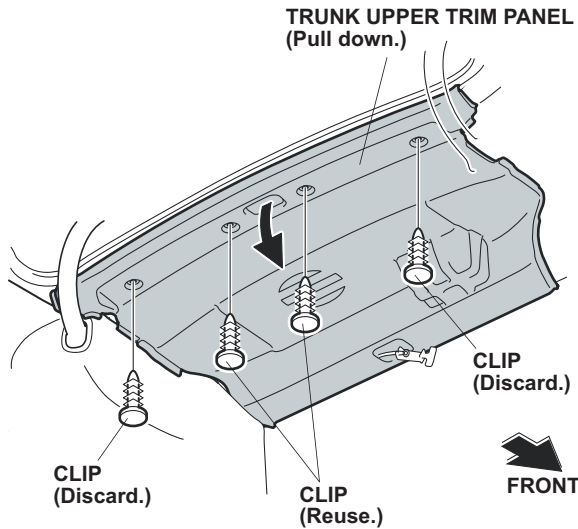

2. Remove the two vehicle bolts from the vehicle panel.

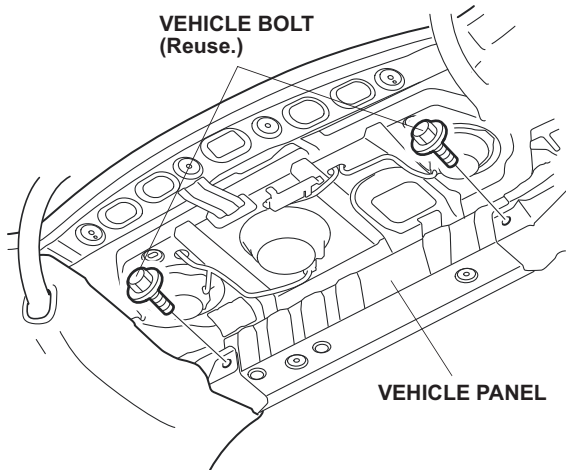

3. While wearing eye protection, enlarge two holes in the rear metal shelf to 10 mm.
 - Place a blanket on the trunk floor to catch the metal shavings.
 - Take care not to damage the wire harness when drilling.
 - Wrap the drill bit with electrical tape 10 mm (0.4 in.) from the tip, or use a drill stop. Do not drill deeper than 10 mm.
 - Remove all burrs and metal shavings, and apply touch-up paint to the edge of each drilled hole. Allow the touch-up paint to dry before proceeding to the next step.

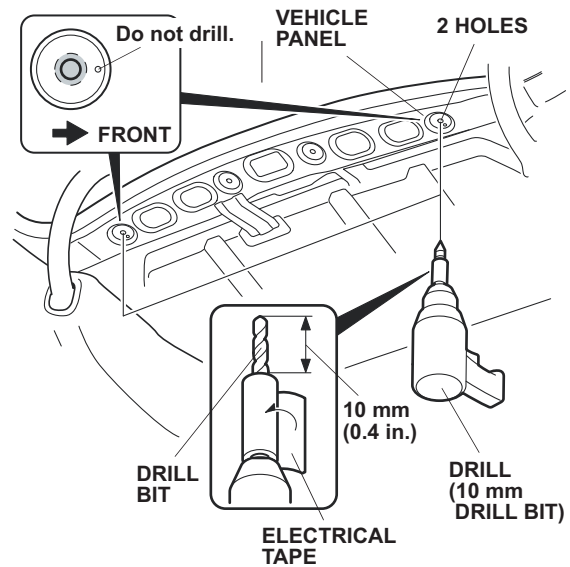

4. Install two 6 mm rivet nuts in the two holes in the vehicle panel by following steps 5 through 8.

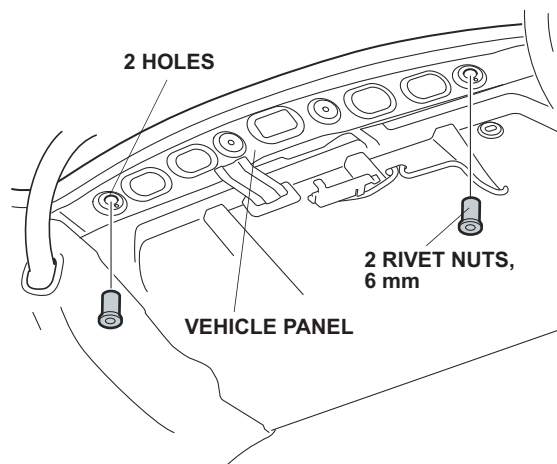

- Thread the 6 mm rivet nut onto the mandrel of the rivet tool as shown.

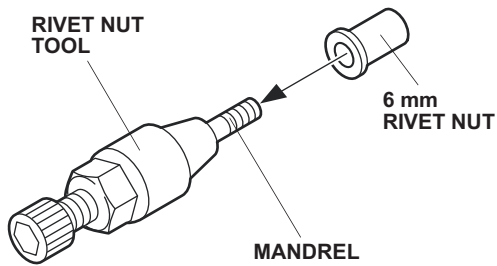

- Insert the 6 mm rivet nut into the hole in the vehicle panel, and attach the hex wrench to the rivet tool.

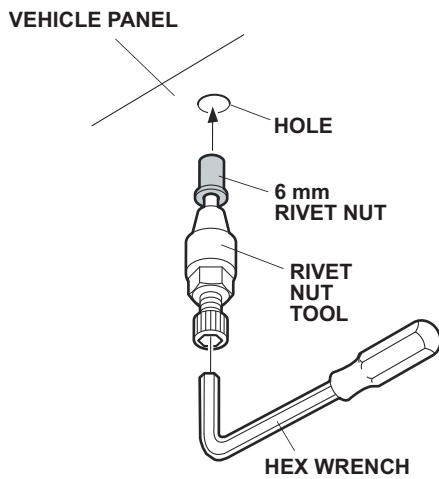

- While holding the rivet nut tool with the hex wrench, turn the 19 mm wrench counterclockwise to install the 6 mm rivet nut to the vehicle panel.

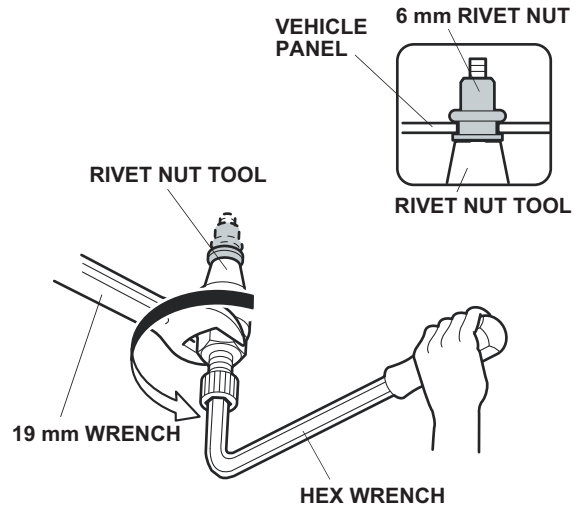

- Remove the rivet nut tool from the 6 mm rivet nut by turning the hex wrench counterclockwise.
- Temporarily install both trunk drawer rails.

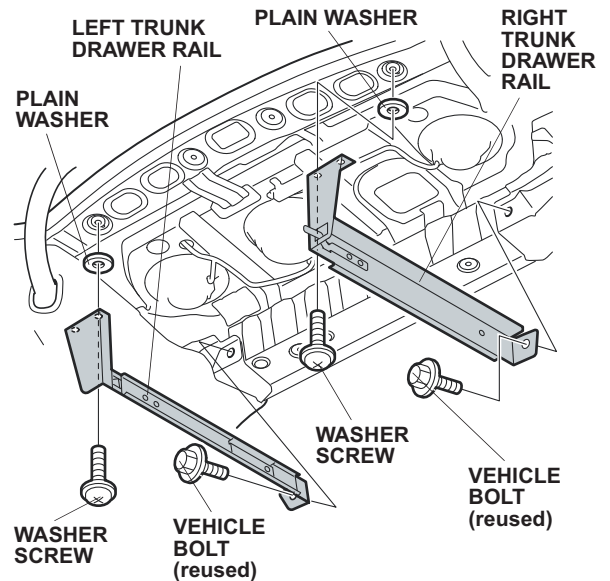

10. On each side, use the trunk drawer rail as a template, and center punch the rear metal shelf through the hole in the rail.

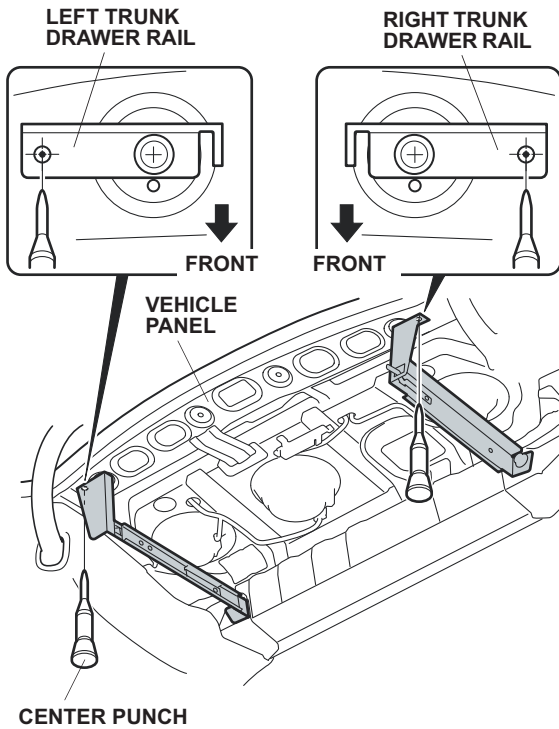

11. Remove the left and right trunk drawer rails.

12. While wearing eye protection, drill the rear metal shelf at the two center punched marks:
- First drill with a 3 mm drill bit, then with a 6 mm drill bit, and finish with a 10 mm drill bit.
 - Wrap each drill bit with electrical tape 10 mm (0.4 in.) from the tip, or use a drill stop. Do not drill deeper than 10 mm.
 - Place a blanket on the trunk floor to catch the metal shavings.
 - Take care not to damage the wire harness when drilling.
 - Remove all burrs and metal shavings, and apply touch-up paint to the edge of each drilled hole. Allow the touch-up paint to dry before proceeding to the next step.

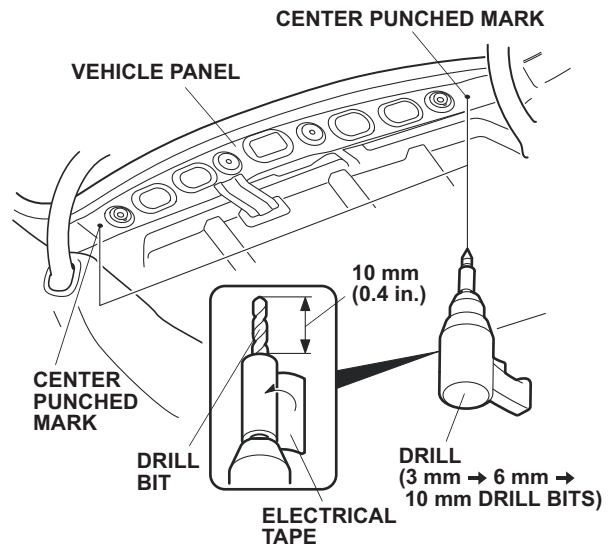

13. Install two 6 mm rivet nuts into the two holes in the vehicle panel by following steps 5 through 8.

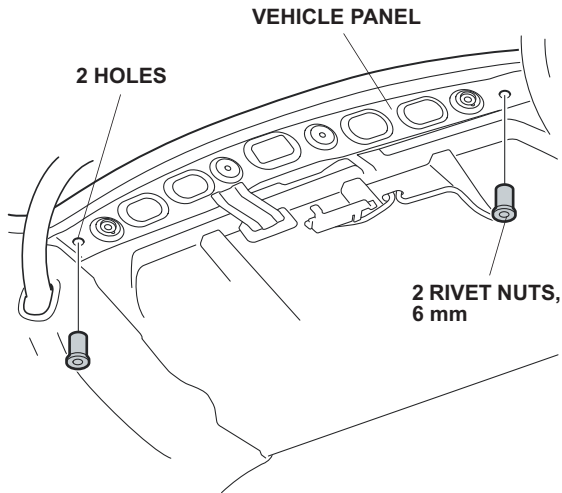

14. Reinstall the trunk upper trim panel using only the two center clips.

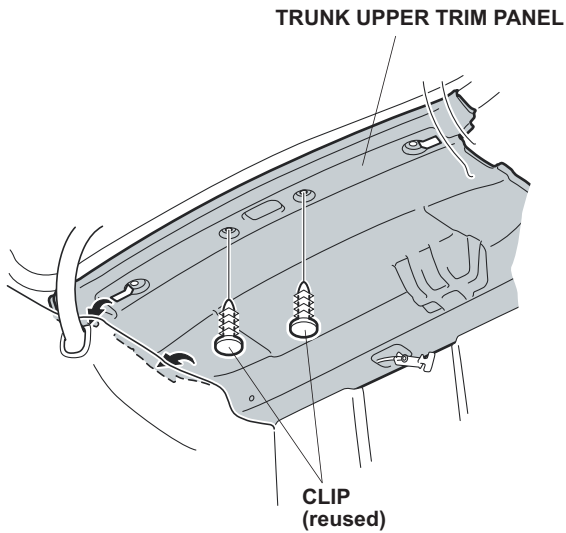

15. Using a utility knife, cut out the trunk upper trim panel at the measurements shown.

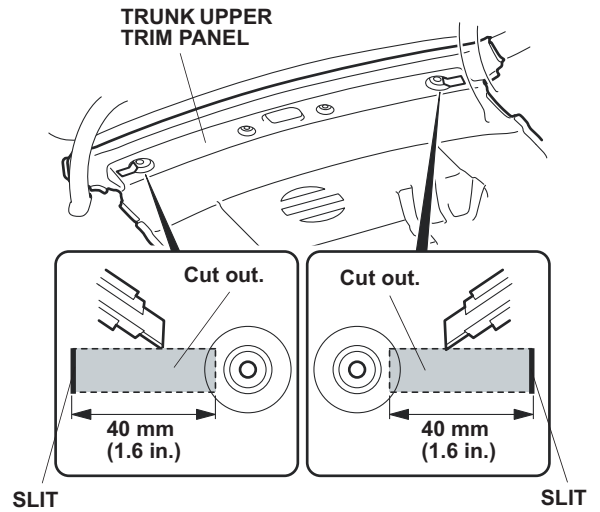

16. Using a utility knife, cut out the three slits in two locations in the trunk upper trim panel.

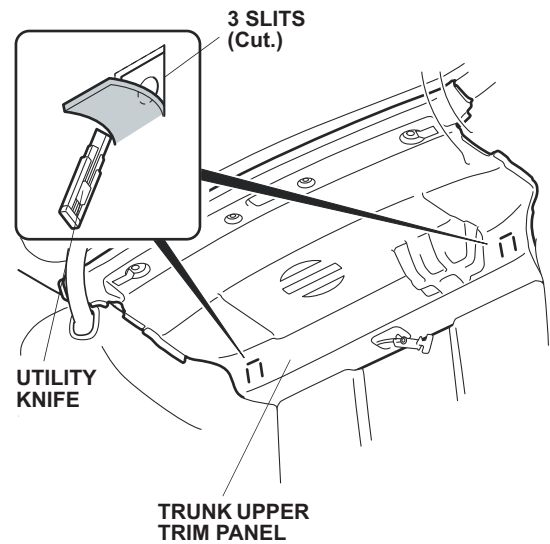

17. Install the left trunk drawer rail on the vehicle panel:
- First, install and tighten the vehicle bolt.
 - Then, install the two washer screws and one plain washer. (Plain washer can be taped to left trunk drawer rail to aid installation).

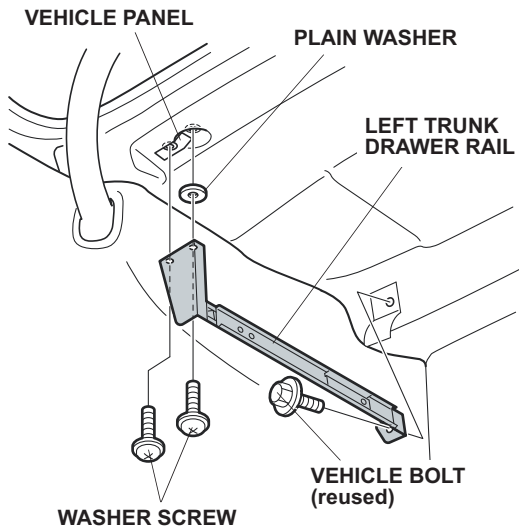

18. Repeat on the right side.

19. Install the trunk storage tray in the left and right trunk drawer:
- Hold the ball-bearing cage in place while inserting the inner rail.
 - Complete one full open/close cycle to test installation.
 - Trunk storage tray should slide smoothly and stop at the fully open position.

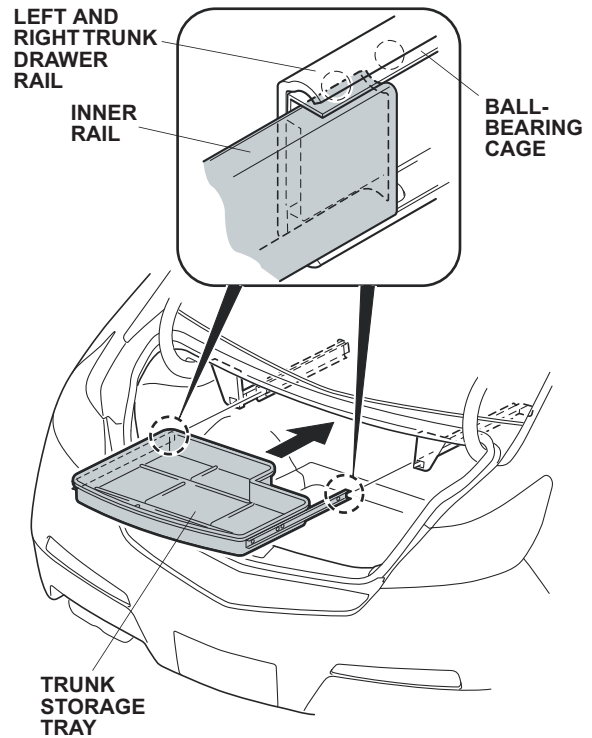

20. Torque the vehicle bolts to 20 N·m (15 lbf·ft).
Torque the washer screw to 4 N·m (3 lbf·ft).