



# INSTALLATION INSTRUCTIONS

Accessory  
**REMOTE CONTROL ENGINE STARTER**

Application  
**2011 TSX L4**

Publications No.  
**BII 44991**  
Issue Date  
**NOV 2010**

## PARTS LIST

### Remote Engine Starter Unit Kit P/N 08E91-TK4-200A

Transmitter

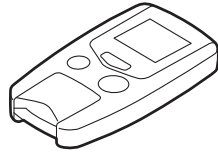

Control unit

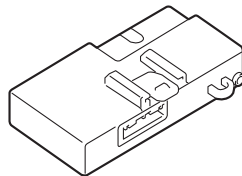

Antenna

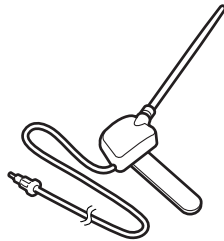

Key ring



Protective tape (black)



Caution label



Fuse label

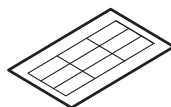

Accessory User's Information Manual

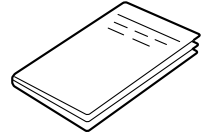

Quick Start Guide

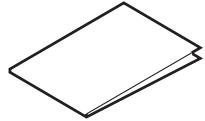

### Remote Control Engine Starter Attachment Kit P/N 08E92-TL2-200A

Engine starter harness

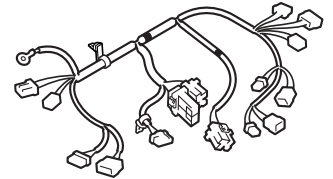

Control unit bracket



Template

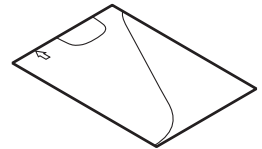

3 Relays

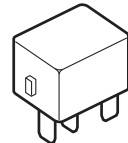

Flange nut



18 Wire ties

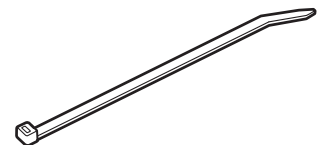

7 Urethane tapes

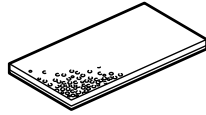

A-Pillar clip



### TOOLS AND SUPPLIES REQUIRED

Phillips screwdriver  
Flat-tip screwdriver  
Small flat-tip screwdriver  
Ratchet  
10 mm Socket  
10 mm Open end wrench  
Diagonal cutters  
Isopropyl alcohol  
Shop towel  
Tape measure  
Scale  
Scissors  
Rubber mallet  
HDS  
Masking tape  
Needle nose pliers  
Trim Tool Set (T/N SOJATP2014)  
Dryer

### Illustration of the Remote Control Engine Starter Installed in the Vehicle

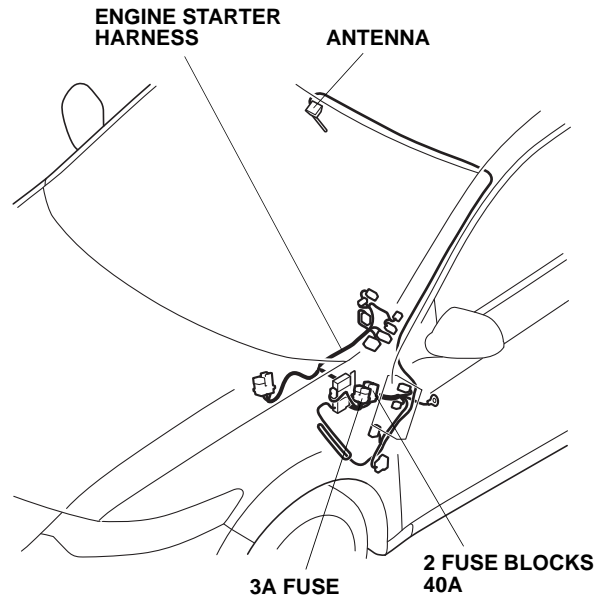

### INSTALLATION

**Client Information:** The information in this installation instruction is intended for use only by skilled technicians who have the proper tools, equipment, and training to correctly and safely add equipment to your vehicle. These procedures should not be attempted by “do-it-yourselfers.”

**NOTE:** This antenna should be installed only if the ambient air temperature 15°C (60°F) or above.

1. Make sure you have the anti-theft code for the radio, then write down the radio station presets.
2. Disconnect the negative cable from the battery.

## Setting the Control Unit

If the vehicle is a sedan, go to step 3.

If the vehicle is a sport wagon, go to step 6.

### Sedan

- Touch the metal part of the screwdriver to any metal part of the vehicle to discharge any static electricity.

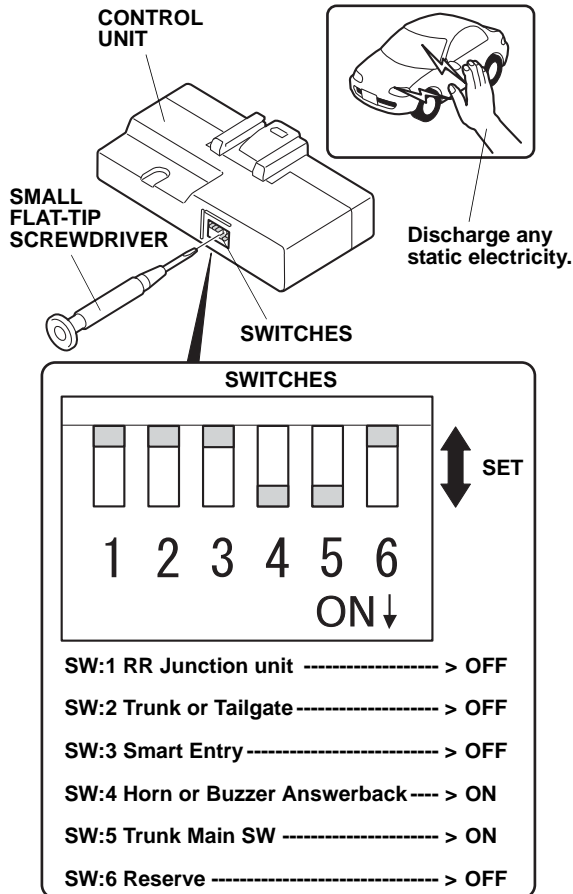

- Check the settings of the switches on the control unit.

#### NOTE:

- The switches must be set before the control unit is plugged in.
- If the switch settings are not correct, the remote control engine starter will not operate correctly.
- If you are setting the switches with the control unit installed in the vehicle, touch the metal part of the screwdriver to any metal part of the vehicle to discharge any static electricity.
- If you change the switch settings with the unit connected, you must disconnect the unit, then reconnect it before the new settings are recognized.

- Using a small flat-tip screwdriver, adjust the switches on the control unit as shown. Go to step 9.

### Sport Wagon

- Touch the metal part of the screwdriver to any metal part of the vehicle to discharge any static electricity.

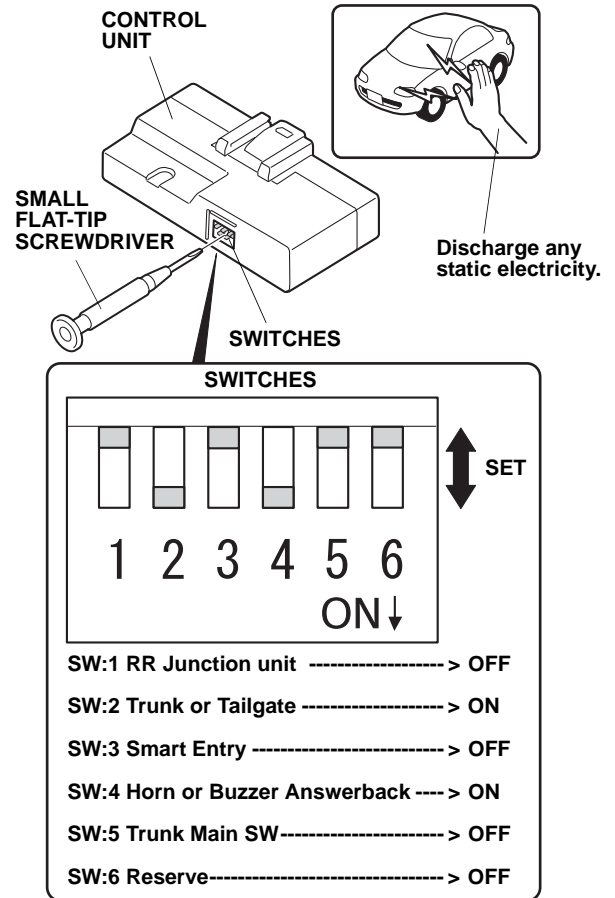

- Check the settings of the switches on the control unit.

#### NOTE:

- The switches must be set before the control unit is plugged in.
- If the switch settings are not correct, the remote control engine starter will not operate correctly.
- If you are setting the switches with the control unit installed in the vehicle, touch the metal part of the screwdriver to any metal part of the vehicle to discharge any static electricity.
- If you change the switch settings with the unit connected, you must disconnect the unit, then reconnect it before the new settings are recognized.

- Using a small flat-tip screwdriver, adjust the switches on the control unit as shown.

9. Using isopropyl alcohol on a shop towel, clean the area where the protective tape will attach. Attach the protective tape to the control unit over the switches.

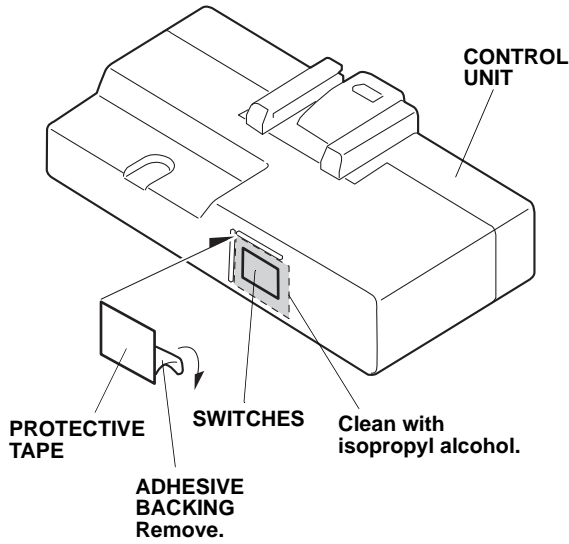

10. Remove the driver's dashboard lower cover (one screw, twelve clips, and unplug the vehicle connector).

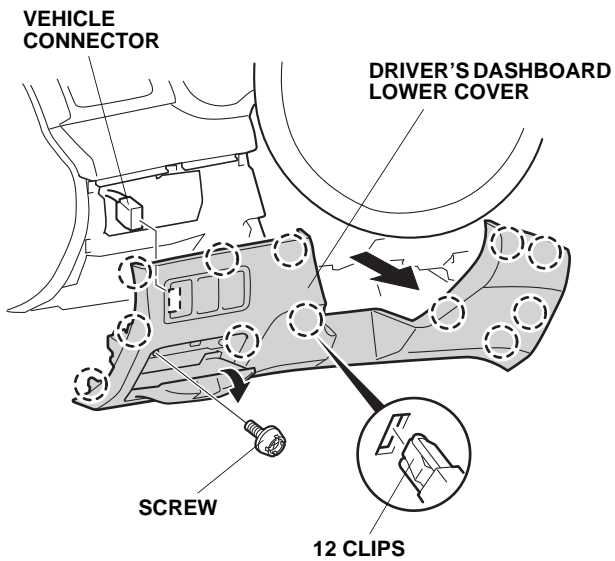

11. Remove the driver's dashboard under cover (two clips and one pin, and unplug the vehicle connector).

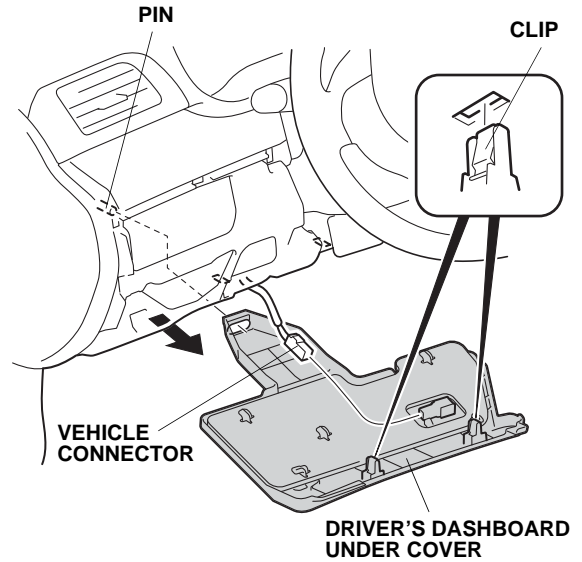

12. Remove the left front door sill trim (four clips and four retaining tabs).

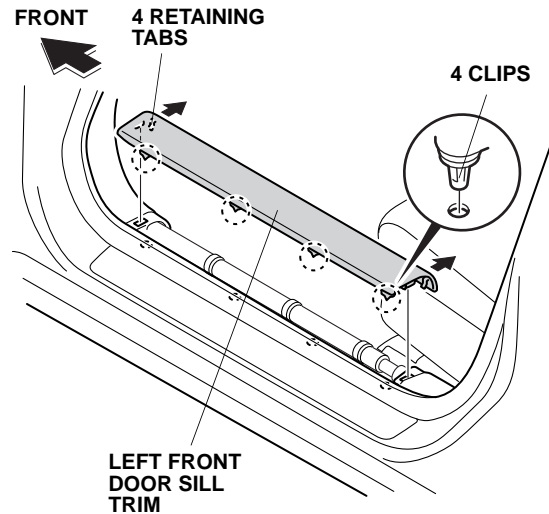

13. Pull back the door opening seal, and remove the left kick panel (two clips).

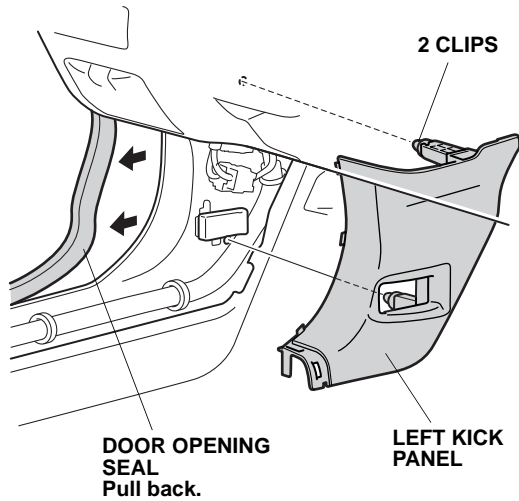

14. Remove the dashboard left side cover (six clips).

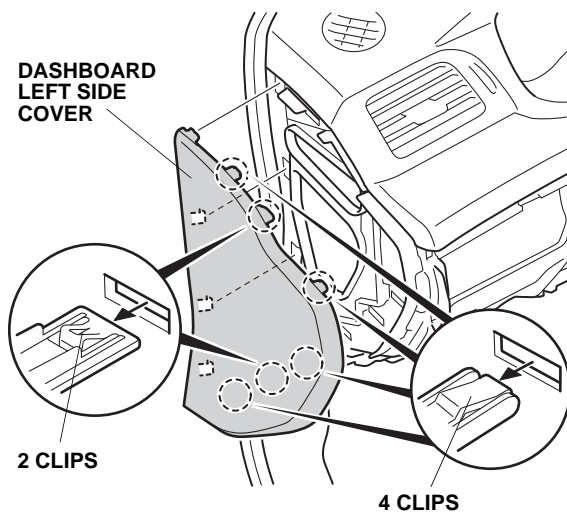

15. Lower the tilt lever and pull the steering wheel out.

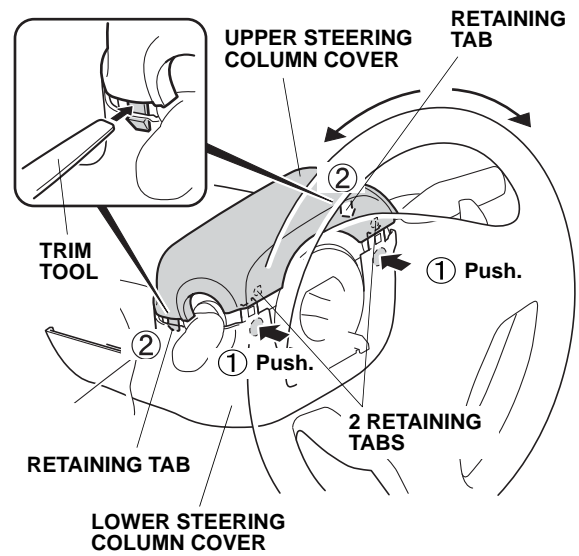

16. Remove the upper steering column cover:

- Turn the steering wheel clockwise to access the tab (point ①). Push in on the lower steering column cover in the areas shown to release the tab. Turn the steering wheel counterclockwise to release the tab on the other side.
- Insert a trim tool between the upper and lower steering column covers to release the retaining tabs (point ②) as shown.
- Insert a trim tool between the upper cover hood and lower steering column cover to release two hood hooks as shown.

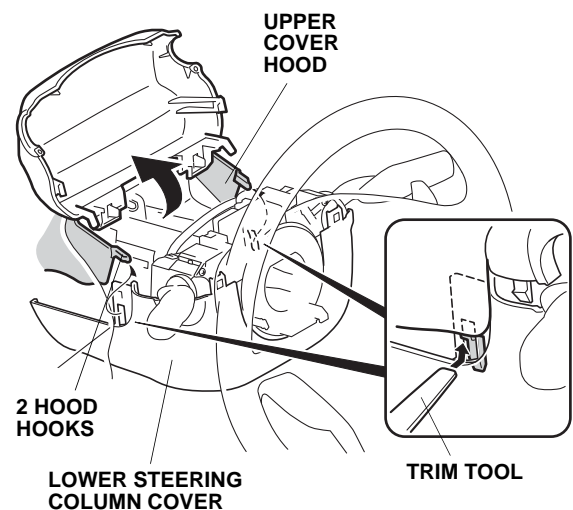

- Remove the upper steering column cover from the upper cover hood (two clips).

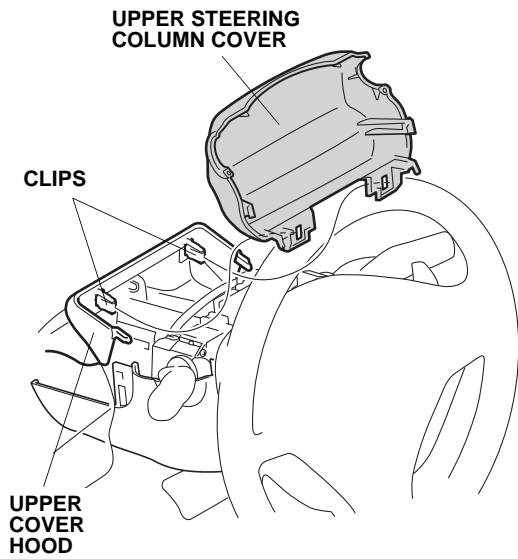

- Remove the lower steering column cover (one screw and two self-tapping screws).

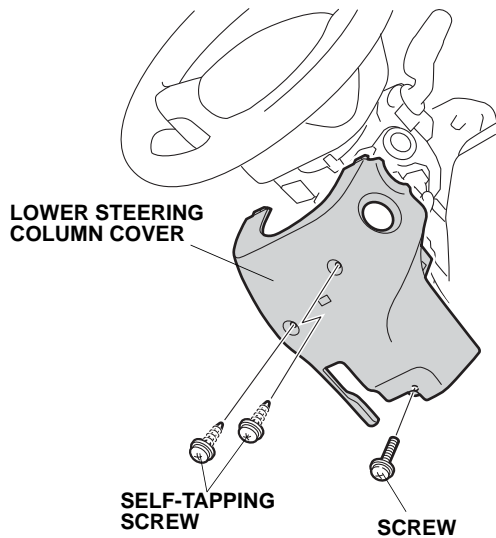

- Remove the roof console:
  - Using a flat-tip screwdriver with a shop towel, pry out and remove the left and right lenses (four retaining tabs each).

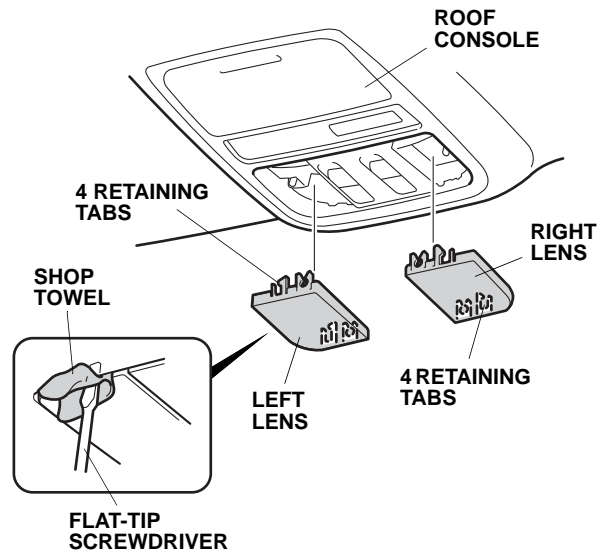

- Open the sunglasses holder, and remove four screws.
- Unplug the vehicle connectors to remove the roof console.

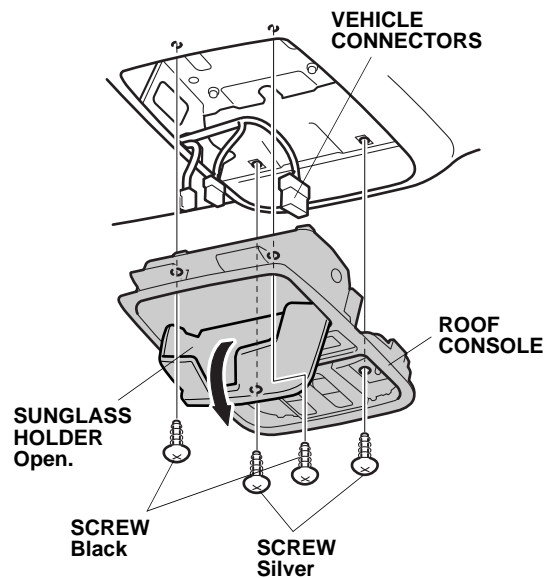

19. Remove each sunvisor holder by turning it 90°.

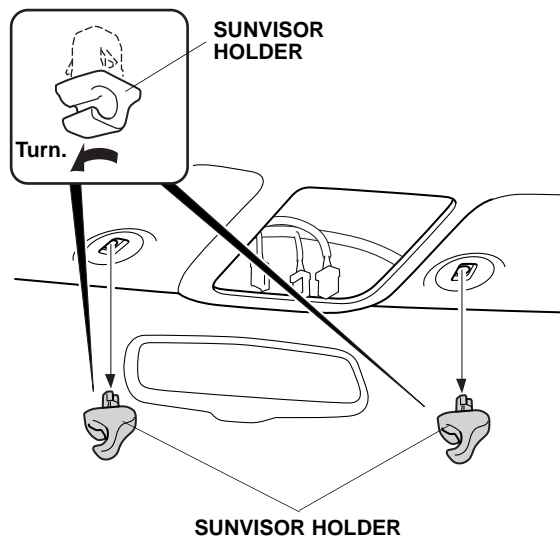

20. Locate the slot in the holder, and insert a flat-tip screwdriver into the slot. Push in and hold the retaining tab.

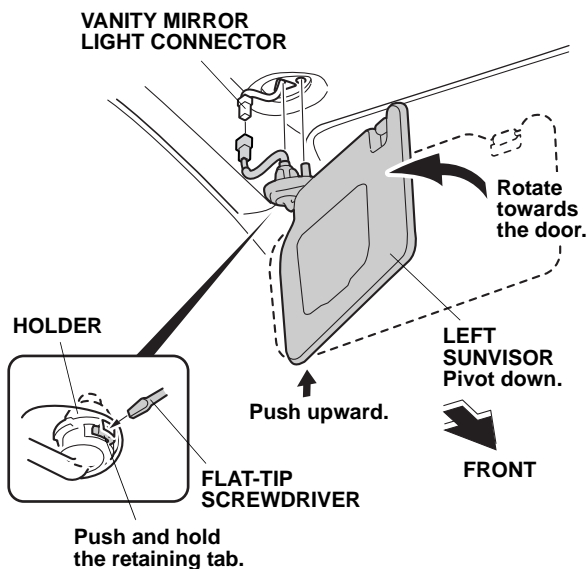

21. While holding the retaining tab, rotate the sunvisor towards the door to remove it. Unplug the vanity mirror light connector. If the retaining tab did not stay pushed in, return the left sunvisor to its original position and repeat steps 20 and 21.

22. Pull the door opening seal away from the left A-pillar trim.

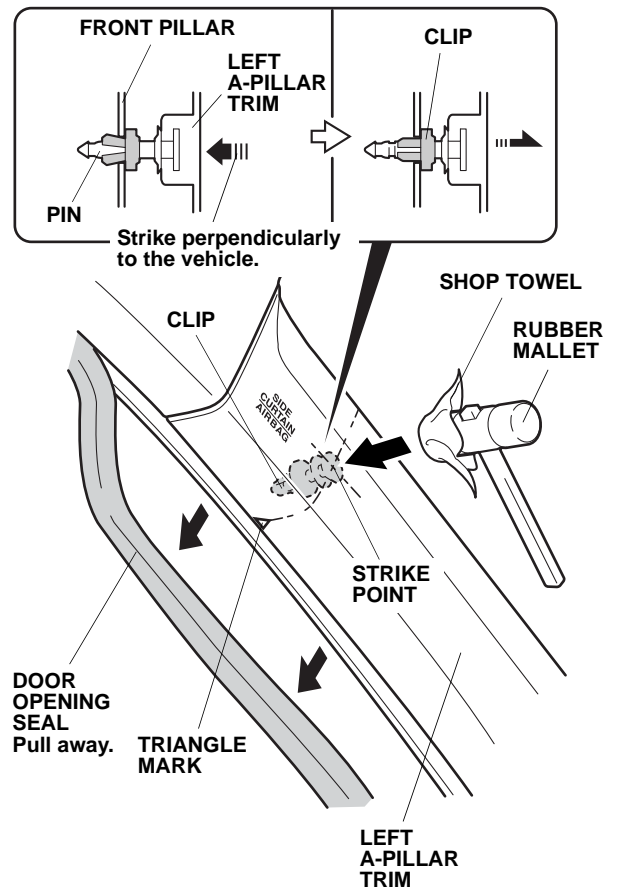

23. Using a rubber mallet and a shop towel, gently tap the left A-pillar trim at the position shown to release the clip.
24. Remove the left A-pillar trim (one clip).

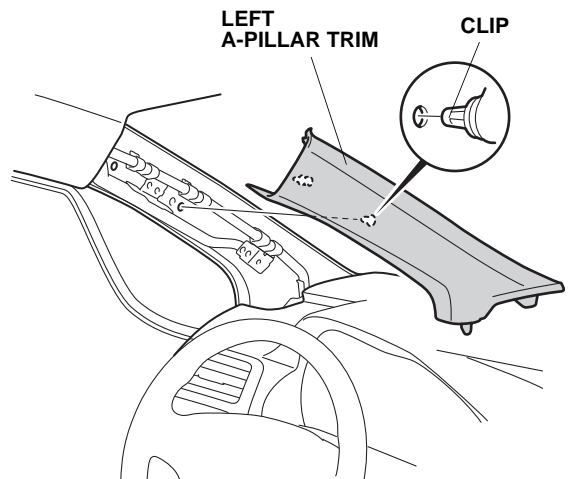

25. Remove and discard the clip from the left A-pillar trim, and install a new A-pillar clip (supplied) on the left A-pillar trim.

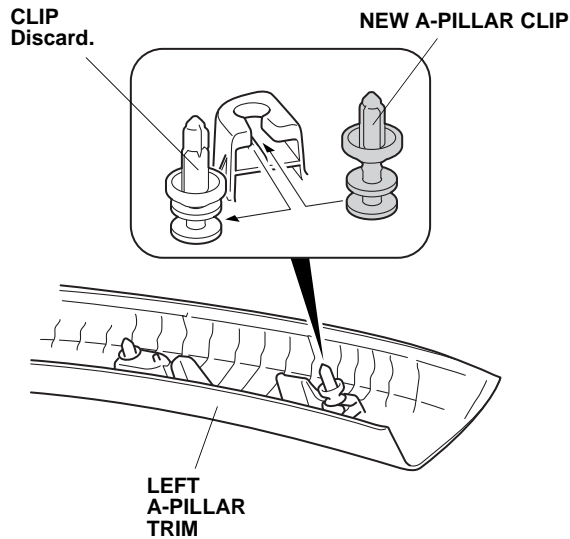

### Routing the Engine Starter Harness

26. Using isopropyl alcohol on a shop towel, thoroughly clean the areas where the fuse labels will attach. Attach two 40A fuse labels to the engine starter harness fuse block.

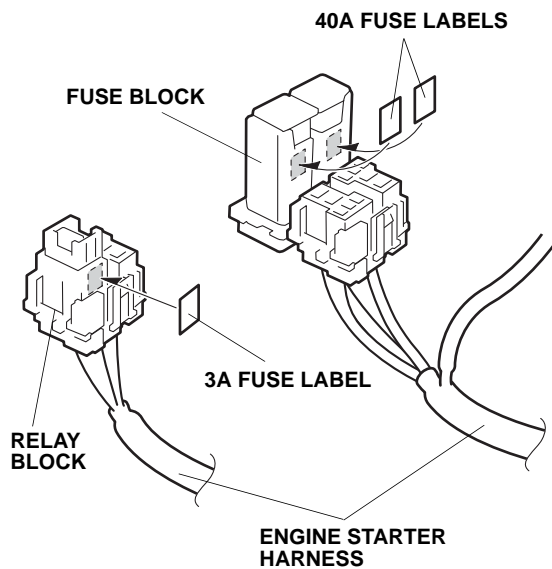

27. Using isopropyl alcohol on a shop towel, thoroughly clean the area where the fuse label will attach. Attach one 3A fuse label to the engine starter harness relay block.

28. Install three relays in the engine starter harness relay blocks.

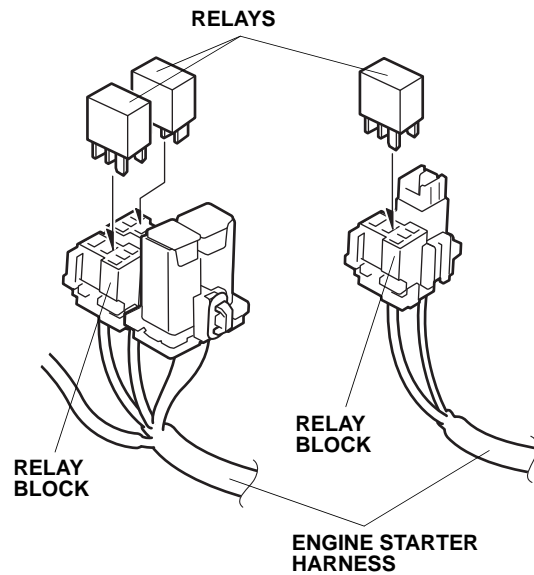

29. Route the 12-pin/8-pin/7-pin/5-pin connector end of the engine starter harness to the ignition switch.

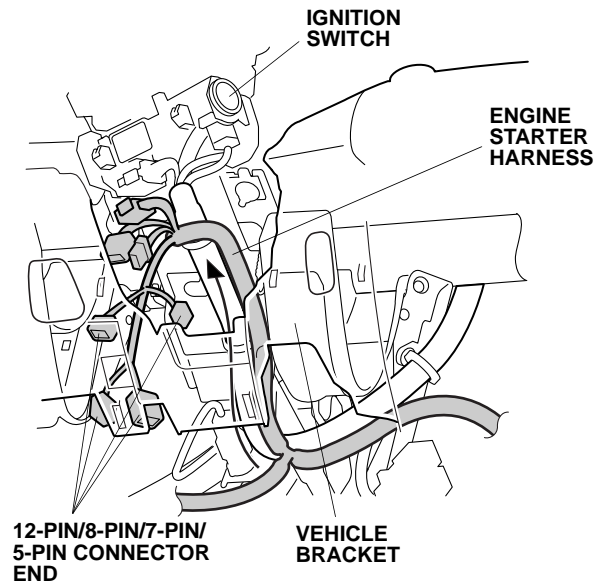

- Unplug the vehicle 5-pin connector from the ignition switch, and plug the engine starter harness 5-pin connector into the ignition switch.

NOTE: Make sure the engine starter harness 5-pin connector is connected securely to the ignition switch. A loose connection can cause the engine to stall during driving.

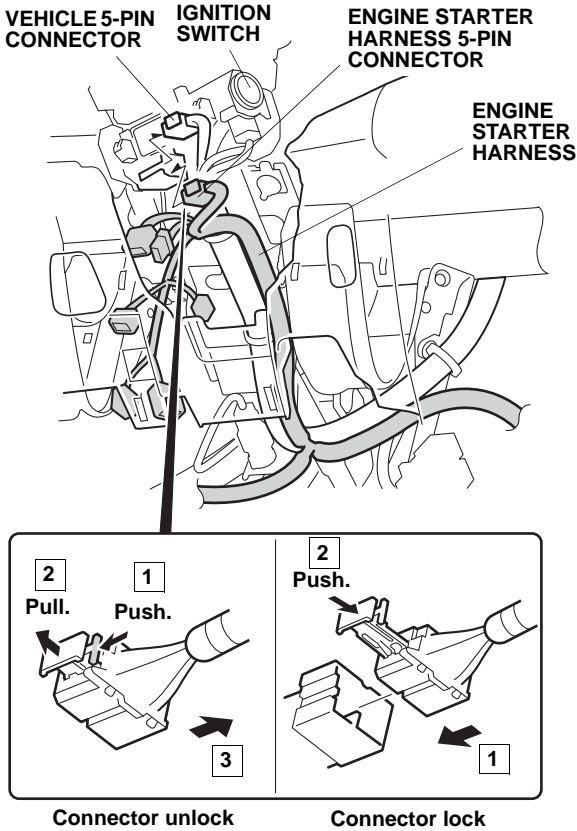

- Wrap one urethane tape around the vehicle 5-pin connector, and tuck it into the area shown.

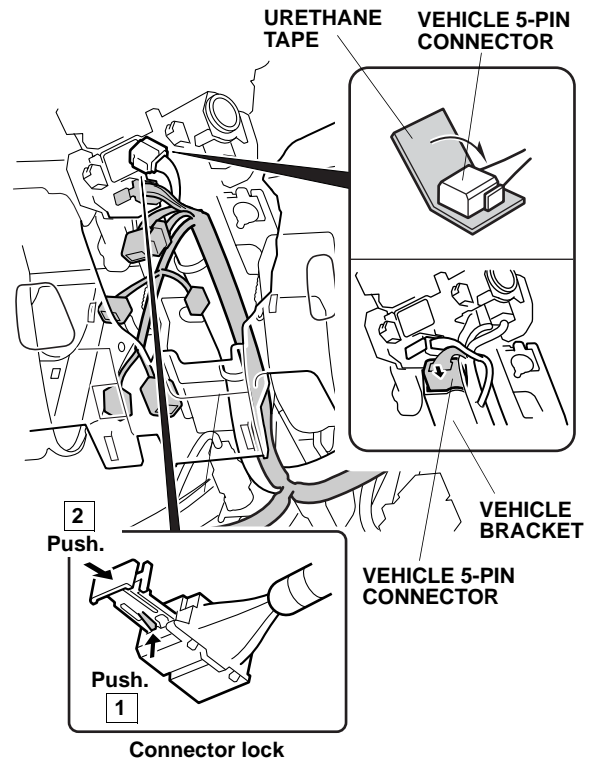

- Unplug the vehicle 7-pin connector, and plug it into the engine starter harness 7-pin connector. Plug the remaining engine starter harness 7-pin connector into the vehicle 7-pin connector.

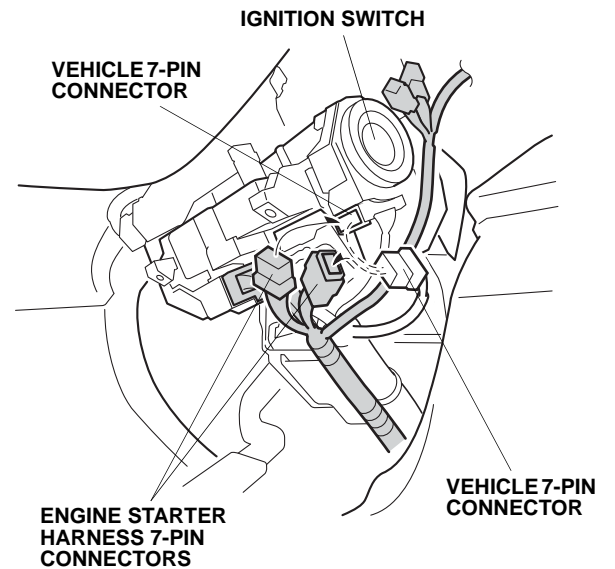

33. Unplug the vehicle 12-pin connector, and plug it into the engine starter harness 12-pin connector. Plug the remaining engine starter harness 12-pin connector into the turn signal switch.

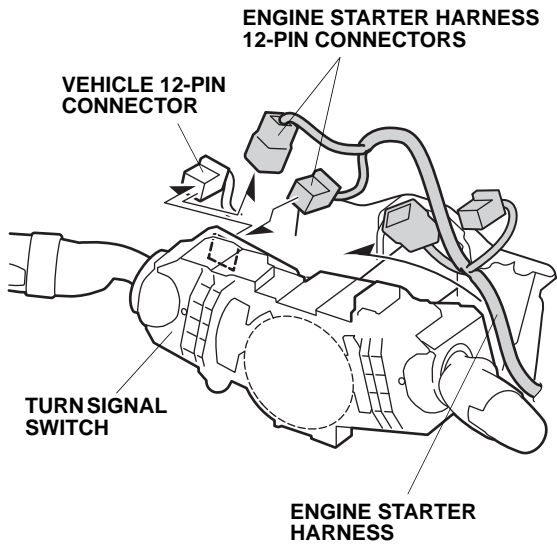

34. Unplug the vehicle 8-pin connector, and plug it into the engine starter harness 8-pin connector. Plug the remaining engine starter harness 8-pin connector into the wiper switch.

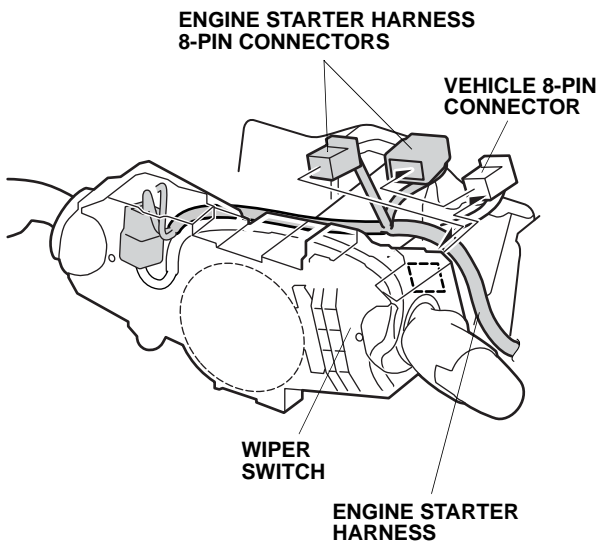

35. Secure the engine starter harness to the vehicle harness with two wire ties. Do not secure it to the SRS harness.

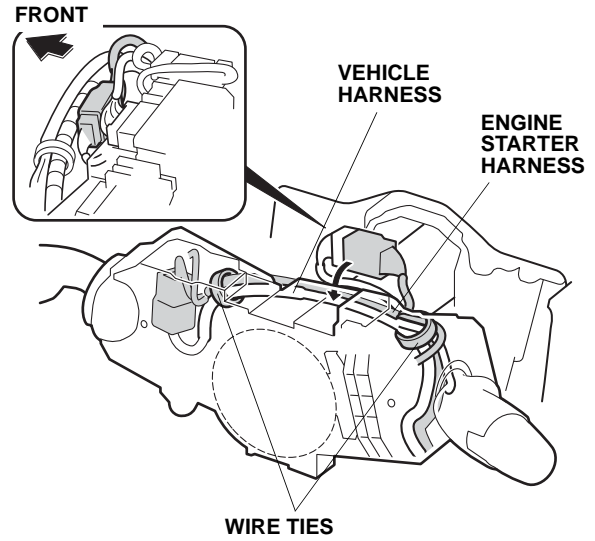

36. Secure the engine starter harness to the vehicle harness with three wire ties in the areas shown.

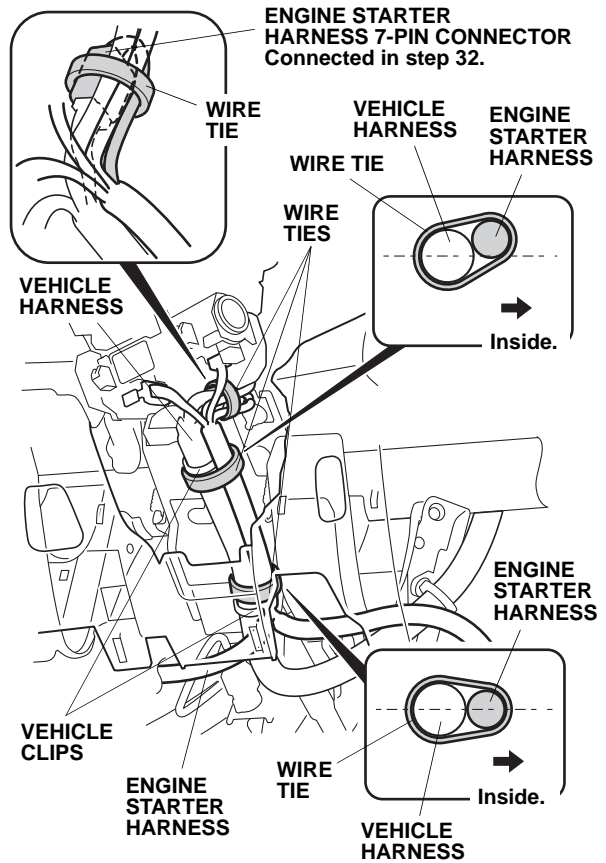

37. Attach the engine starter harness relay block onto the vehicle relay block as shown.

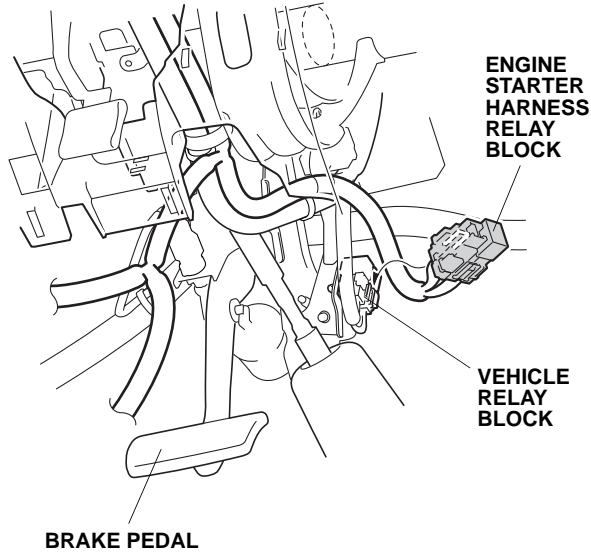

38. Align the white tape on the engine starter harness with the holes in the dashboard behind the tilt lever as shown, and secure the engine starter harness to the dashboard with one wire tie.

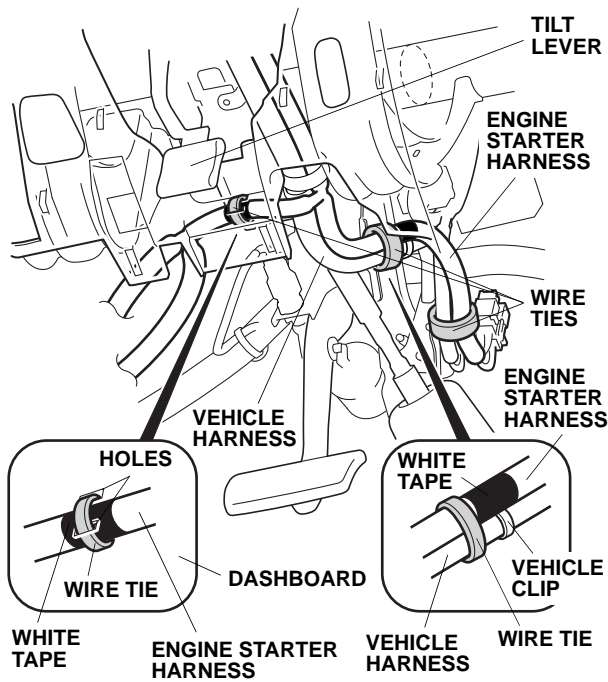

39. Align the white tape on the engine starter harness with the vehicle clip as shown, and secure the engine starter harness to the vehicle harness with one wire tie.
40. Secure the engine starter harness to the vehicle harness with one wire tie at the location shown.

41. Route the engine starter harness through the opening in the vehicle frame in front of the fuse box.

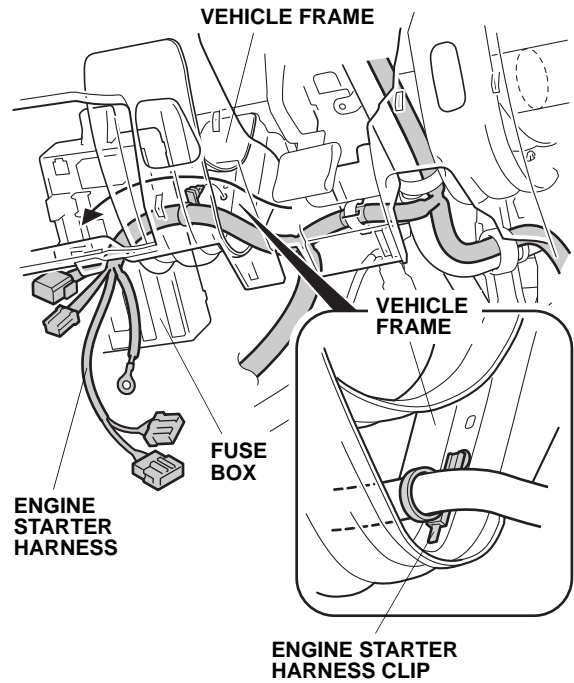

42. Attach the engine starter harness clip to the hole in the vehicle frame as shown.

43. Unplug the vehicle 5-pin connector from the fuse box. Plug the engine starter harness 5-pin connector into the fuse box 5-pin connector. Wrap one urethane tape around the vehicle 5-pin connector.

NOTE: Make sure the engine starter harness 5-pin connector is securely connected to the fuse box 5-pin connector. A loose connection can cause the engine to stall during driving.

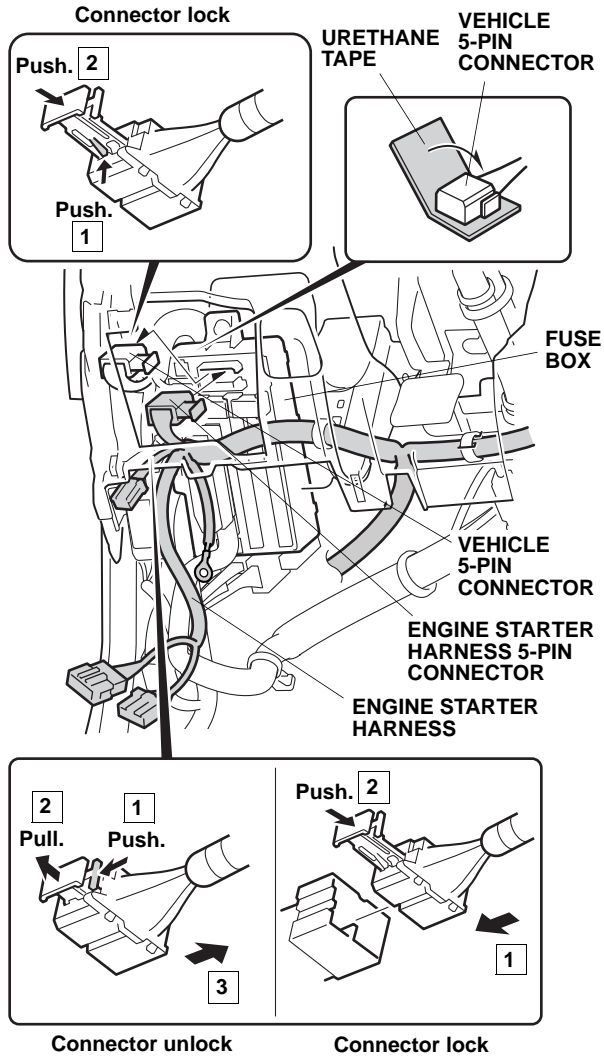

44. Secure the vehicle 5-pin connector unplugged in step 43 to the vehicle harness with one wire tie.

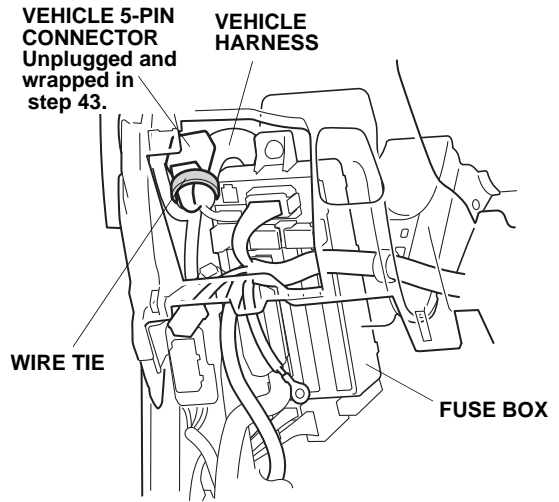

45. Plug the engine starter harness 12-pin connector into the fuse box 12-pin connector.

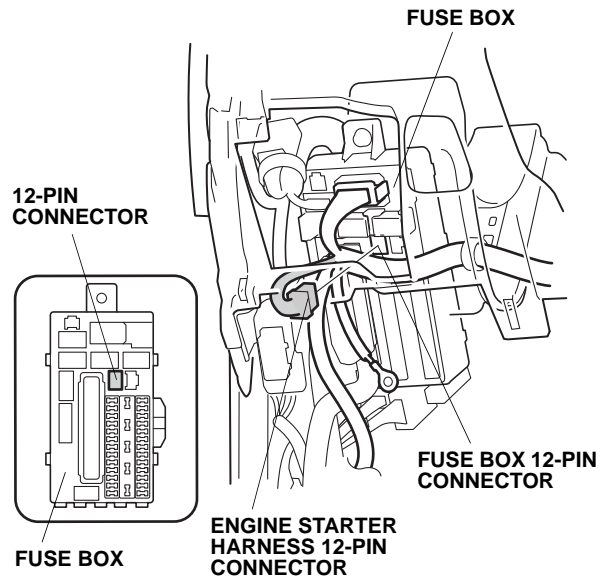

46. Remove the vehicle ground bolt. Attach the engine starter harness ground terminal to the vehicle ground terminal, and reinstall the vehicle ground bolt as shown.

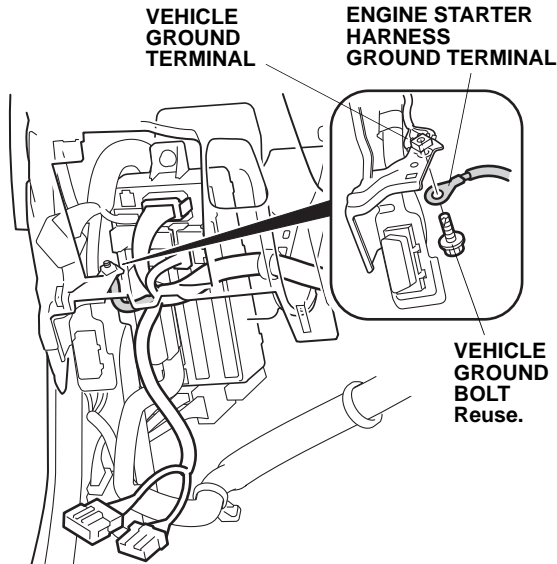

47. Loosely install one wire tie around the engine starter harness and the vehicle harness.

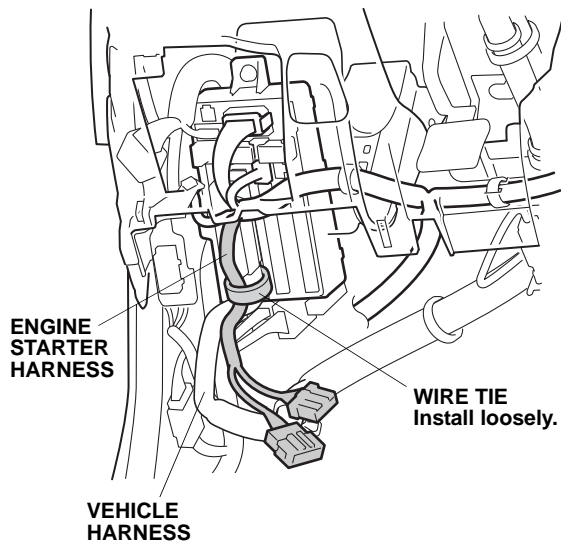

48. Unplug the vehicle 24-pin connector from the fuse box, and plug the engine starter harness 24-pin connector into the fuse box. Plug the remaining engine starter harness 24-pin connector into the vehicle 24-pin connector.

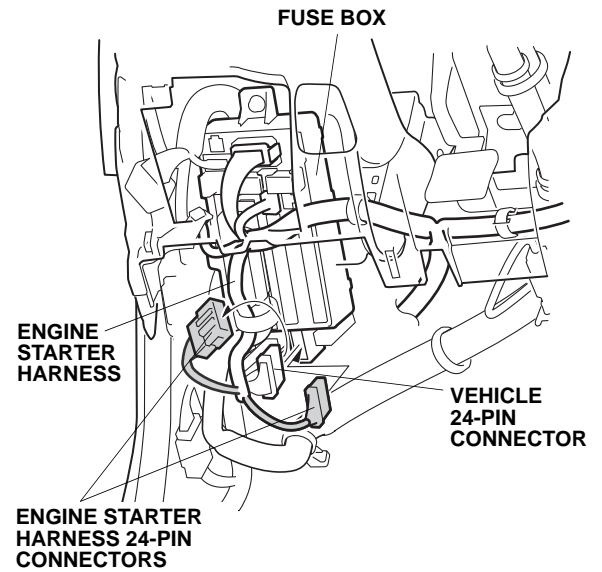

If the vehicle is equipped with a power tailgate, go to step 49; if not, go to step 52.

### With power tailgate

49. Detach the vehicle 2-pin connector from the vehicle 8-pin connector.

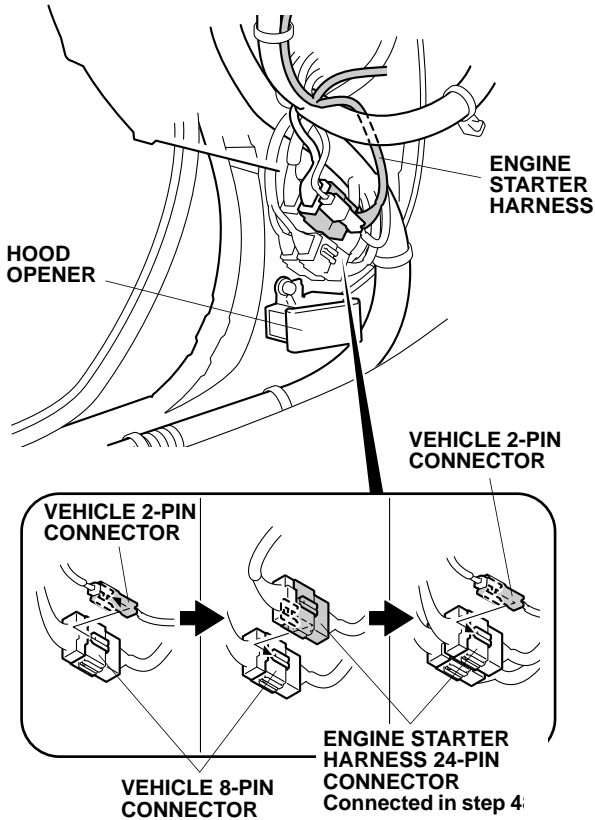

50. Attach the engine starter harness 24-pin connector onto the vehicle 8-pin connector.
51. Attach the vehicle 2-pin connector onto the engine starter harness 24-pin connector. Go to step 53.

### Without power tailgate

52. Attach the engine starter harness 24-pin connector onto the existing vehicle 8-pin connector already attached to the side panel.

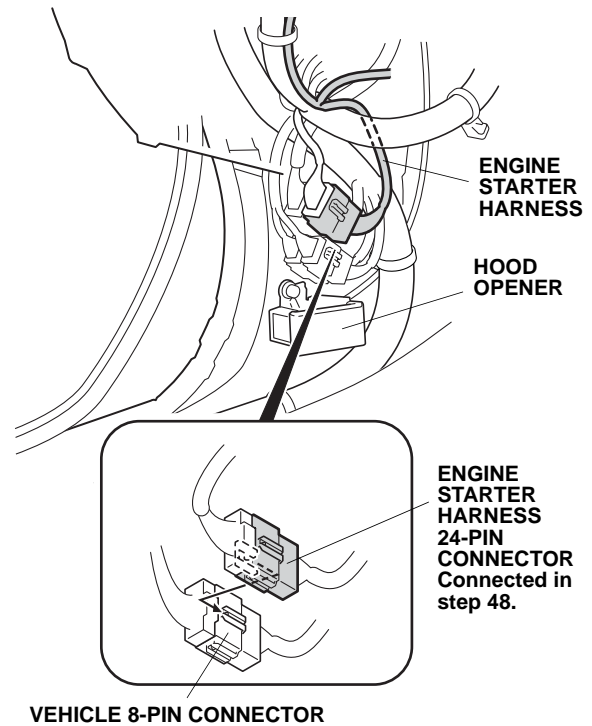

### Installing the Antenna

53. Use scissors to cut out the template.

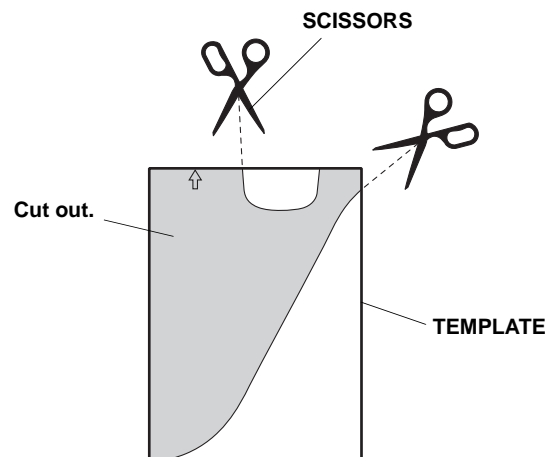

54. Using two pairs of needle nose pliers, bend the antenna plate according to the full scale drawing below.

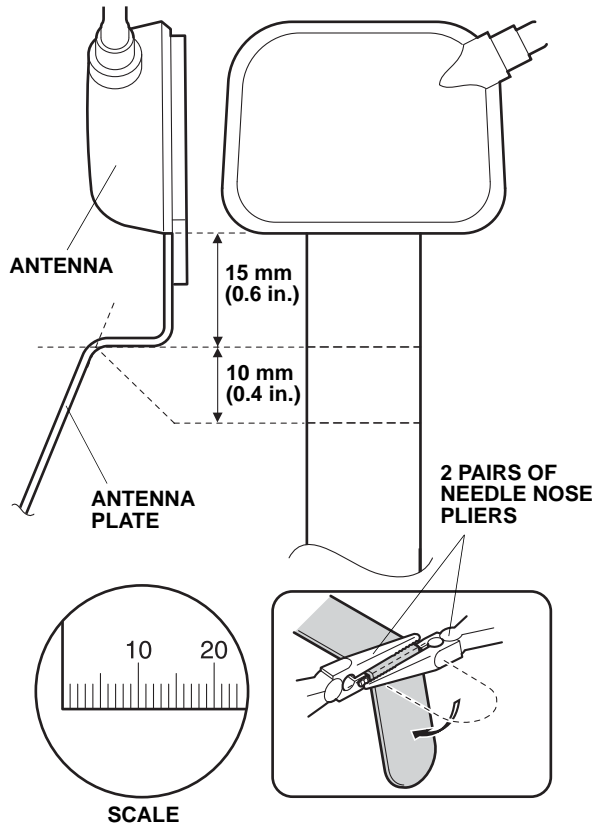

55. Starting at the antenna end of the cable, wrap three urethane tapes around the antenna cable at the measurements shown.

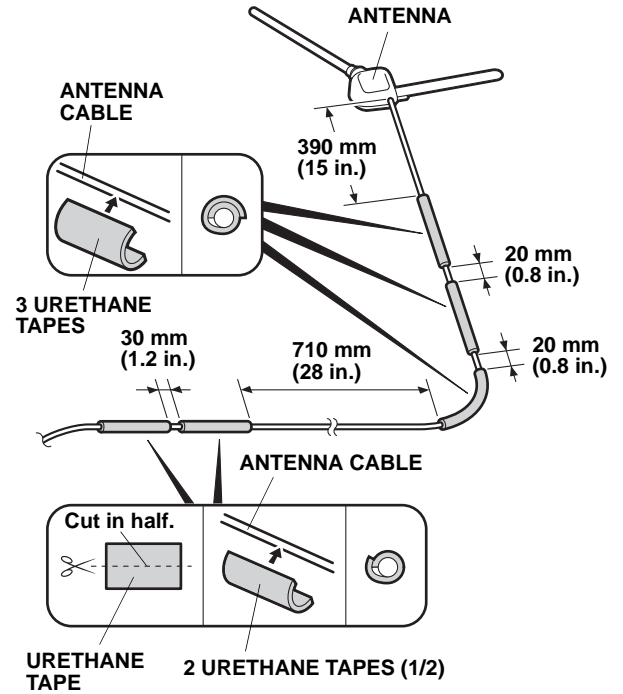

56. Cut one urethane tape in half. Wrap the two cut pieces of urethane tape around the antenna cable at the measurements shown.
57. Attach the template to the windshield. Align it with the black ceramic as shown.

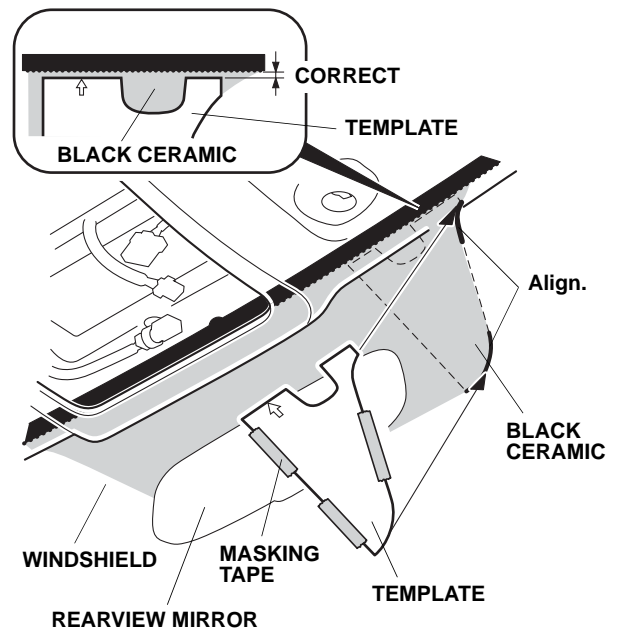

58. Using isopropyl alcohol on a shop towel, thoroughly clean the area where the antenna will attach.

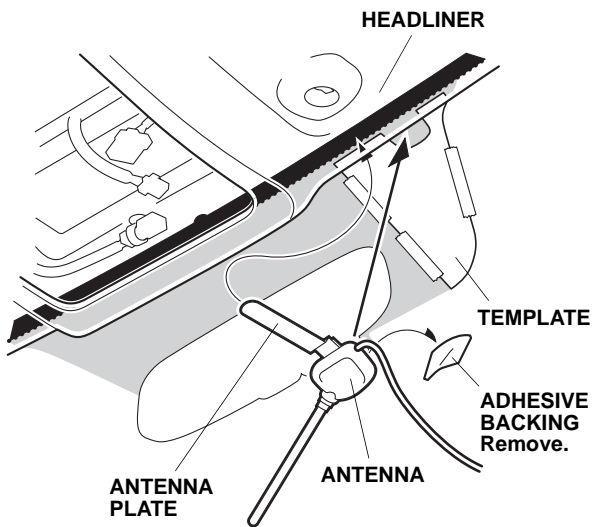

59. Remove the adhesive backing from the antenna. Insert the antenna plate behind the headliner, align the antenna with the template, and attach the antenna to the windshield.
60. Remove the template.
61. Gently pull down the headliner, and tuck the antenna cable behind it. Be careful not to crease the headliner.

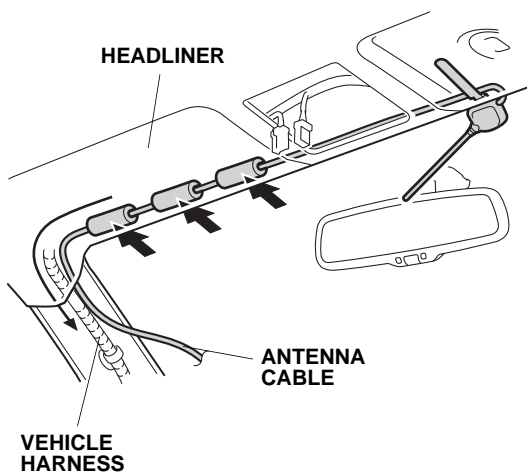

62. Using isopropyl alcohol on a shop towel, thoroughly clean the area where the urethane tape will attach.

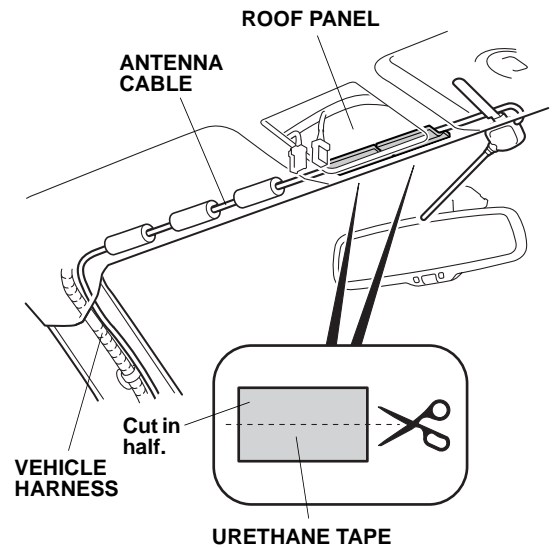

63. Use scissors to cut one urethane tape in half. Secure the antenna cable to the roof panel with the two cut pieces of urethane tape.
64. Pull back the door opening seal. Route the antenna cable down under the dashboard. Tuck the antenna cable between the left front A-pillar and the dashboard, and reinstall the door opening seal.

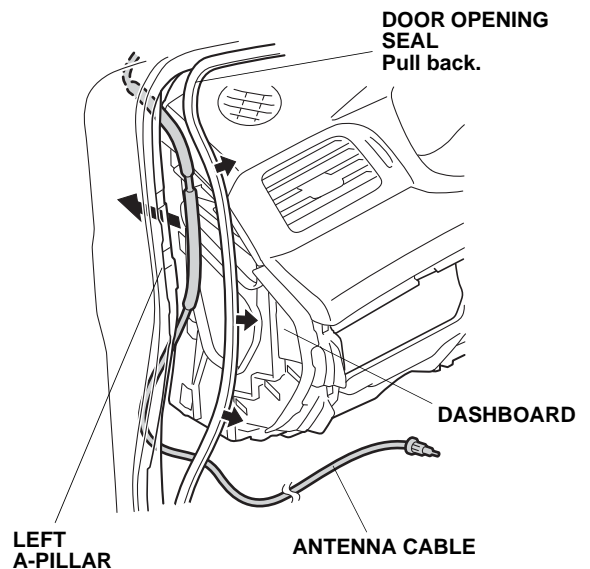

65. Secure the antenna cable to the vehicle harness with four wire ties. If the vehicle is equipped with a moonroof, do not secure the wire ties to the front drain tube.

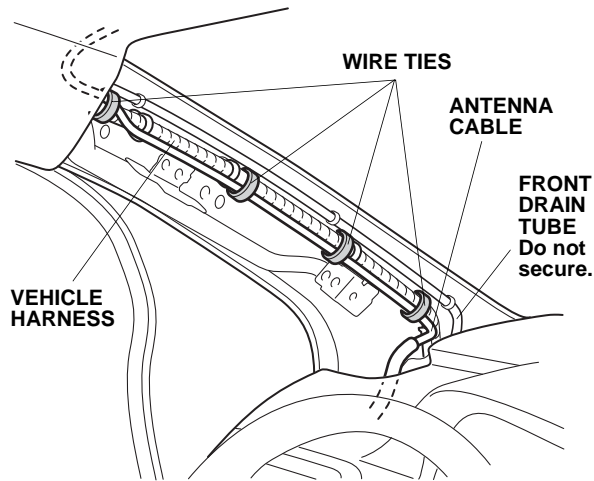

66. Secure the antenna cable with the one wire tie loosely installed to the vehicle harness in step 47.

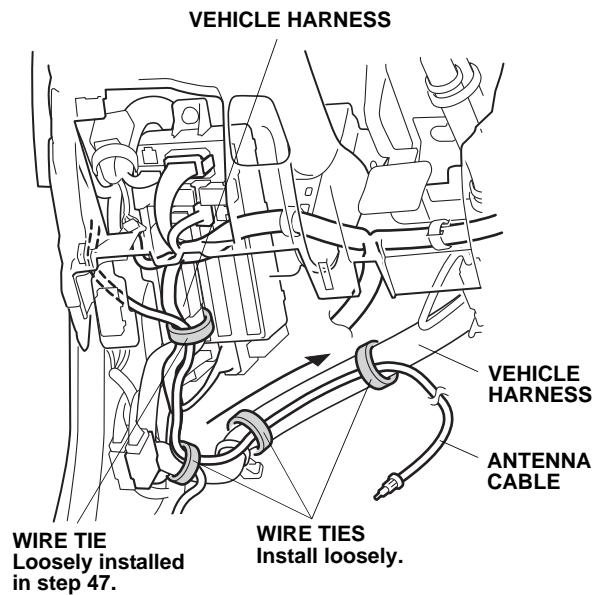

67. Route the antenna cable along the vehicle harness, and loosely install three wire ties around the antenna cable and the vehicle harness.

## Installing the Control Unit

68. Install the control unit bracket to the control unit.

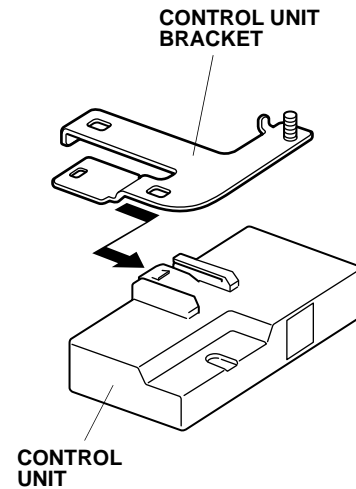

69. Plug the engine starter harness 28-pin connector into the control unit.

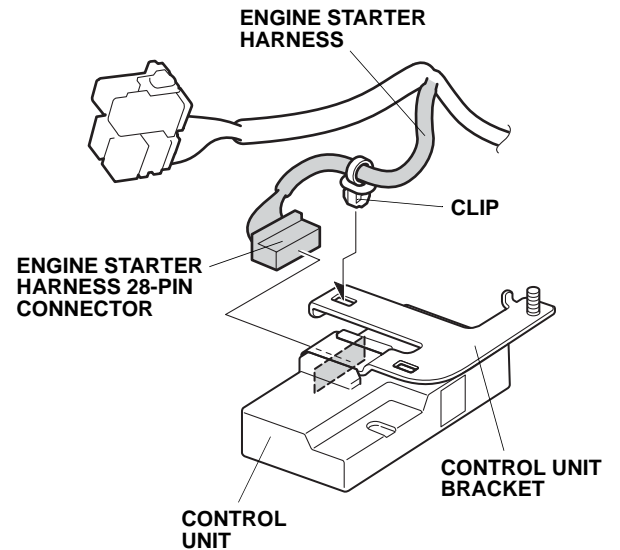

70. Install the clip on the engine starter harness to the control unit bracket.

71. Plug the antenna terminal into the control unit as shown.

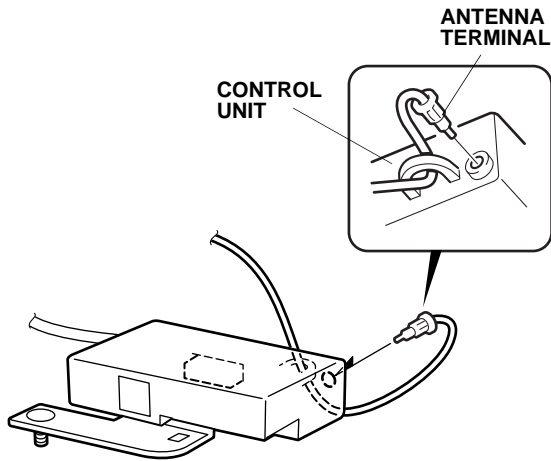

72. Insert the stud on the control unit bracket through the hole in the vehicle frame, and secure the control unit bracket to the vehicle frame with one flange nut.

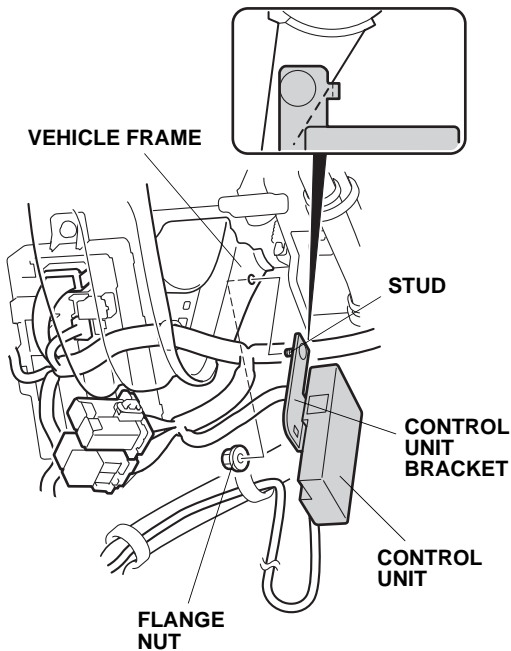

73. Secure the engine starter harness relay block clip to the vehicle frame.

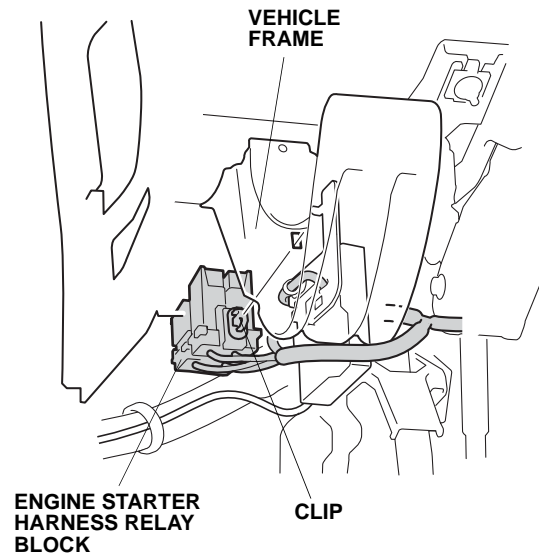

74. Bundle the excess antenna cable. Insert the bundled cable under two wire ties loosely installed in step 67. Secure the antenna cable with the remaining loosely-installed wire tie.

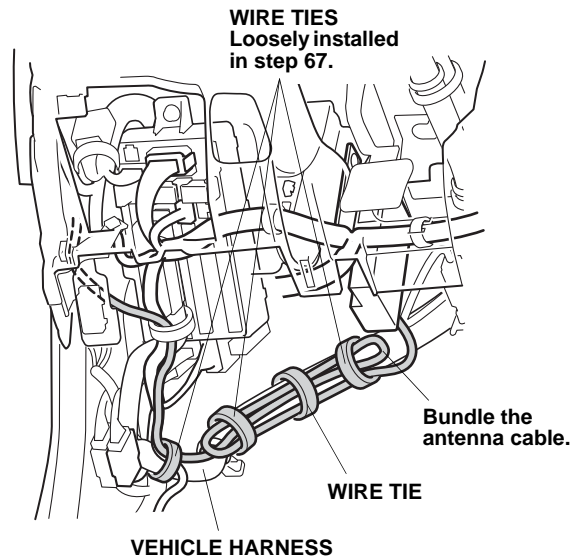

75. Secure the antenna cable to the vehicle harness with one additional wire tie.

76. Open the hood, and locate the area where the caution label will attach. Using isopropyl alcohol on a shop towel, thoroughly clean the area where the caution label will attach.

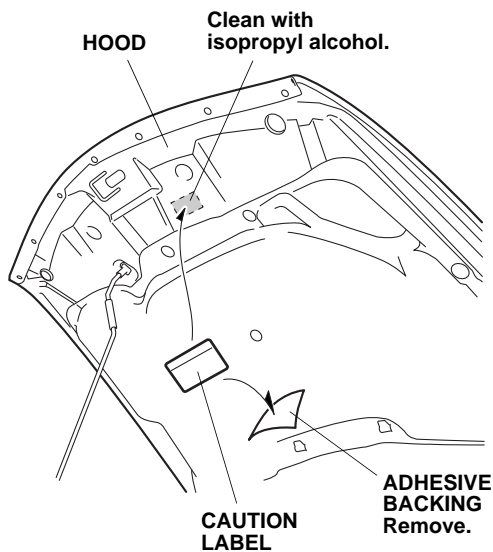

77. Attach the caution label to the hood as shown.
78. Check that all wire harnesses and cables are routed properly and that all connectors are plugged in.
79. Reinstall all removed parts. Check that all clips and other fasteners are installed securely. Take care not to pinch the side curtain airbag with the clip during reinstallation of the left A-pillar trim. Do not push excessively on the A-pillar trim.
80. Reconnect the negative cable to the battery. Check that all electrical accessories and other electrical systems function properly.
81. Enter the client's radio anti-theft code and reset the radio station presets.
82. Reset the clock on models without a navigation system.
83. Do the "REMOTE ENGINE STARTER REGISTRATION" and "FUNCTION CHECK."

## REMOTE ENGINE STARTER REGISTRATION

1. Acquire the PCM Code from the Interactive Network.
2. Connect the HDS tester to the OBD II data link connector, then turn the ignition switch to the on (II) position.
3. Start the HDS, and click the car icon.

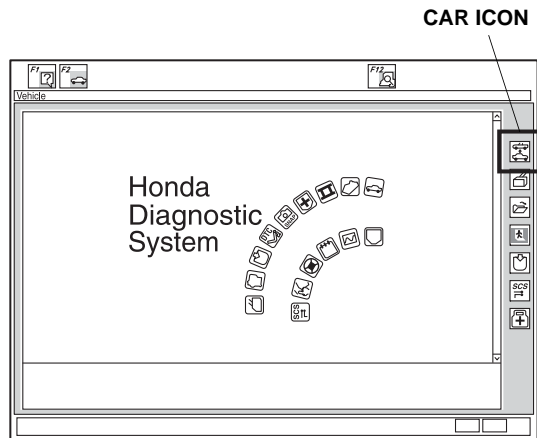

4. Input the VIN and other required information into the HDS, then click the check button.

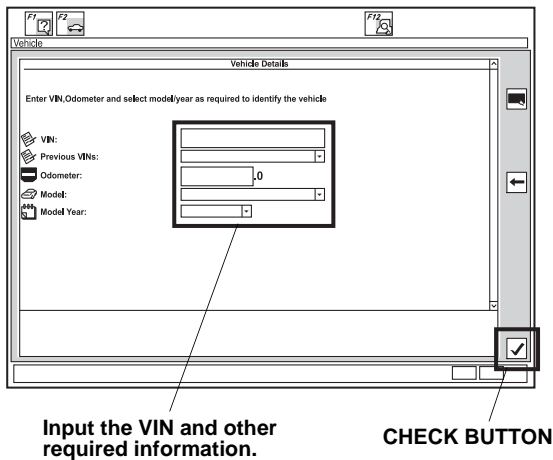

5. Select **Honda Systems**, then click the check button.

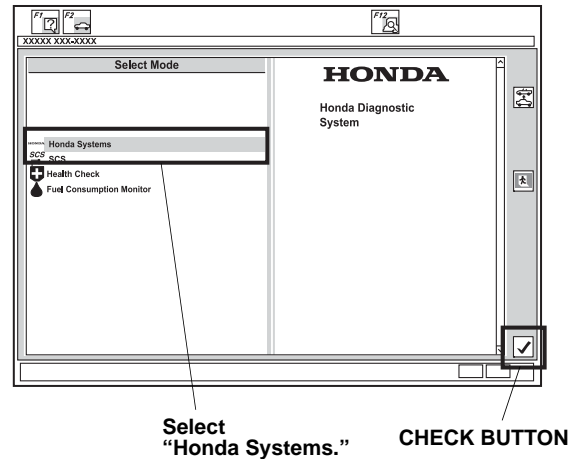

6. Select **R/C ENG STARTER** and click the check button.

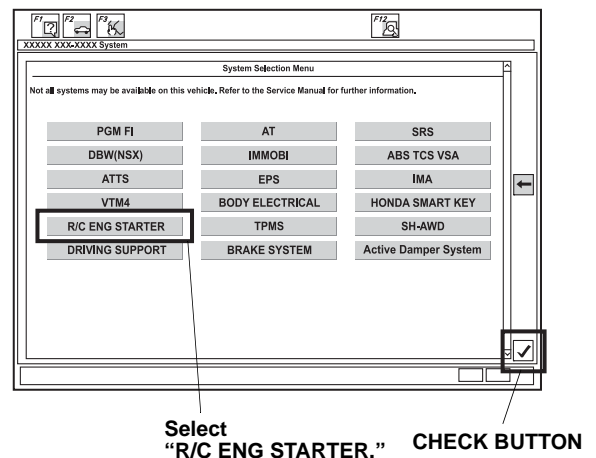

7. A **REMARKS** message will display. Click on the check button.

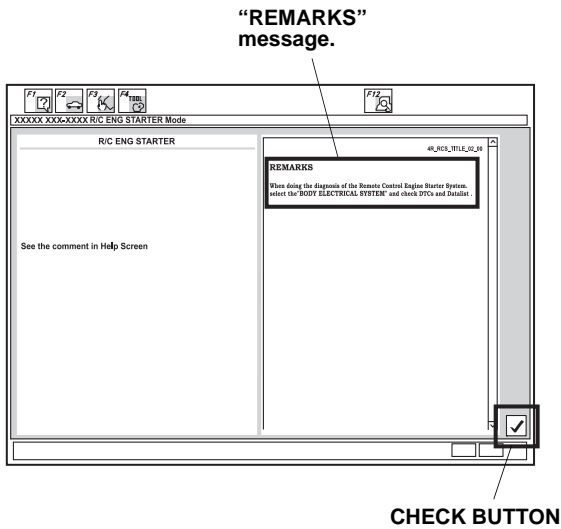

8. Select **REGISTER REMOTE CONTROL ENGINE STARTER UNIT**, then click the check button.

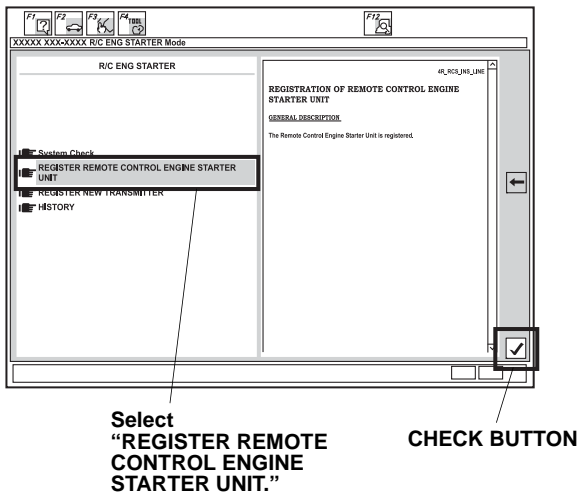

9. The following message will display: **Obtain PCM code (IMMOBILIZER PCM CODE) from IN. This vehicle’s VIN will be required to obtain the password (USA).** Click on the check button.

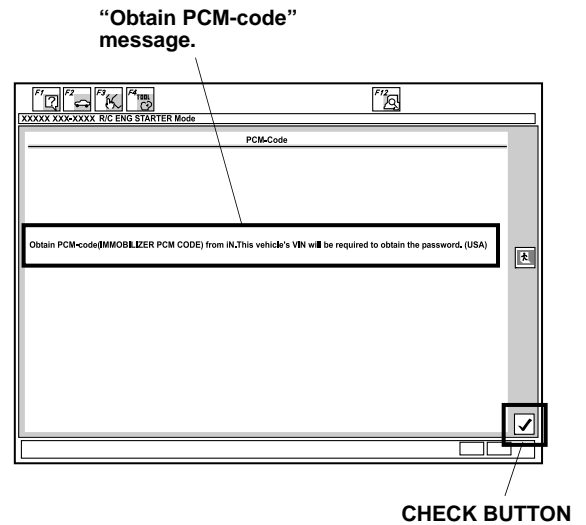

10. Input the PCM Code, then click the check button.

NOTE: To ensure security, the PCM code (password) is changed every day, so it is impossible to register the remote control engine starter if the dates of the PCM code acquisition and registration are different. The date on the HDS tester should also be the same.

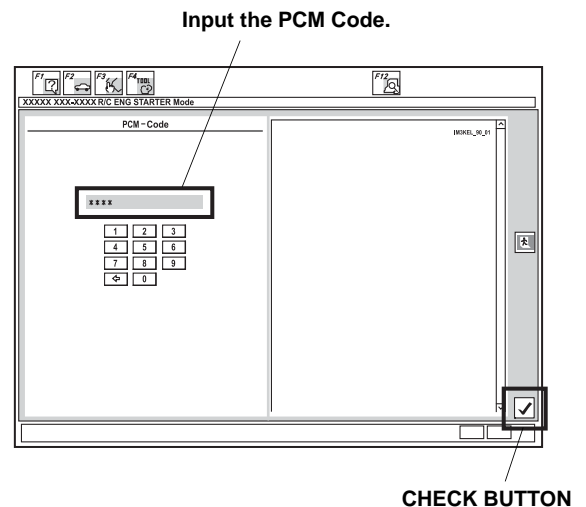

11. The following message will display: **The registration of the Remote Control Engine Starter Unit has been completed.** Click on the check button.

“The registration of the Remote Control Engine Starter Unit has been completed.”

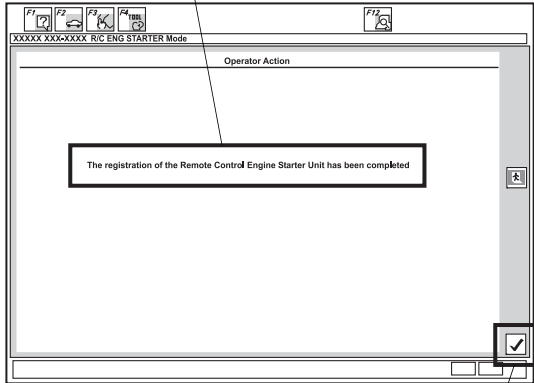

CHECK BUTTON

12. The following message will display: **Check that the engine can be started by the Transmitter.** Click on the check button.

“Check that the engine can be started by the Transmitter.”

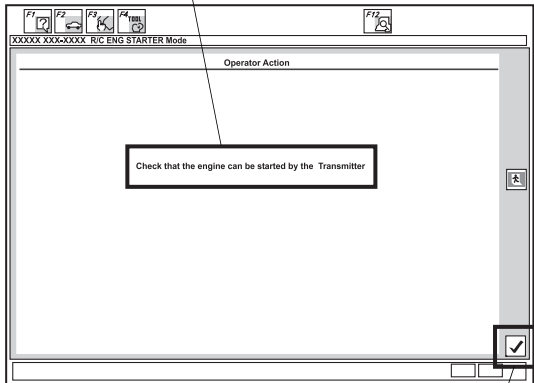

CHECK BUTTON

13. Perform the Function Check on page 23, then disconnect the HDS.

## FUNCTION CHECK

### Operating Conditions

- Hood is closed
- Shift lever in park
- The key is out of the ignition switch
- All doors and trunk lid or tailgate closed and locked

### Inspection

1. Press the command button, and then, within one second, press the start button on the transmitter.  
The engine should start if all operating conditions are met.

Does the engine start?

Yes - Operation is normal.
No: <ul style="list-style-type: none"><li>• Make sure all "Operating Conditions" are met.</li><li>• Check the engine starter harness connections.</li><li>• Connect the HDS and check for an indicated failure. (Refer to the appropriate service manual for details.)</li></ul>

2. Press the command button on the transmitter and, within 1 second, press the stop button. The engine should stop.

Does the engine stop?

Yes - Operation is normal.
No - Check the engine starter harness connections.

3. After the engine has stopped, start the engine again, and check that the engine stops after each of the following conditions:

NOTE: After each test the ignition switch must be cycled, or the driver's door must be opened and closed.

- Move the shift lever out of the P position.
- Unlock or open the doors or the trunk lid or tailgate.
- Open the hood.
- Insert the key in the ignition switch.
- Press the brake pedal.

Does the engine stop after each of these tests?

Yes - Operation is normal.
No - Check the engine starter harness connections.

4. Check that the power windows and the moonroof do not function, and that the shift lever does not move to any position but the P position when the engine is started with the transmitter.
5. Start the engine again, press the command button on the transmitter two times, and check the vehicle condition on the display.
6. Check the operation of the transmitter when the vehicle is 100 m to 150 m (325 to 490 ft.) away and in direct sight.

