



# INSTALLATION INSTRUCTIONS

Accessory

DOOR VISORS  
P/N 08R04-TL2-200

Application

2011 TSX

Publications No.

BII 44979

Issue Date

NOV 2010

## PARTS LIST

Left front door visor

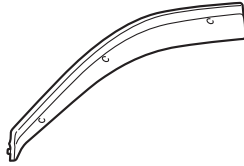

Right front door visor

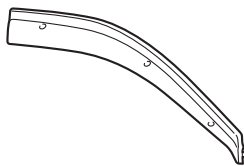

Left rear door visor



Right rear door visor



4 Brackets B



4 Brackets C



10 Clips



2 Brackets D

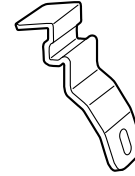

2 Washers



## TOOLS AND SUPPLIES REQUIRED

Isopropyl alcohol

Shop towel

Masking tape

Ruler

### *Illustration of the Door Visors Installed on the Vehicle*

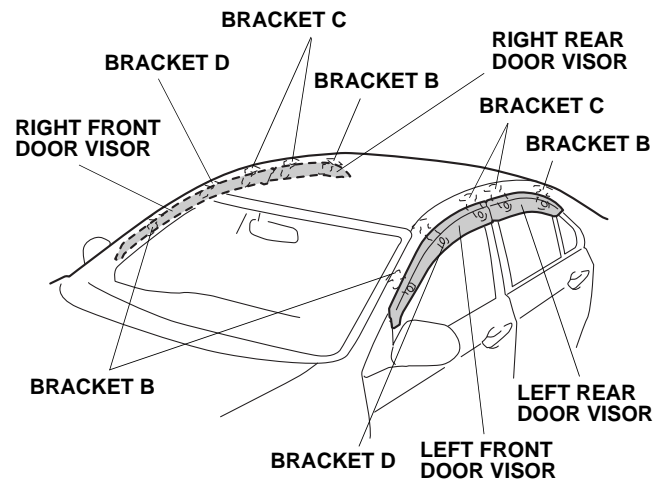

**Client Information:** The information in this installation instruction is intended for use only by skilled technicians who have the proper tools, equipment, and training to correctly and safely add equipment to your vehicle. These procedures should not be attempted by “do-it-yourselfers.”

**NOTE:**

- Visors may not be legal in all states. Please check your local regulations.
- These instructions show the left door visors being installed. The same procedure applies to installing the right door visors.
- Be careful not to damage the paint finish and the glass run channels when installing the door visors.
- Handle the door visors with care. They are not designed to absorb shock or impact.
- This door visor kit should be installed only if the ambient air temperature is 15°C (60°F) or above.
- To allow the adhesive to cure, do not wash the vehicle for 24 hours.

**Installing the Front Door Visors**

1. Fully lower the left front door glass.
2. Remove the run channel as shown. Do not remove the run channel at the corners.

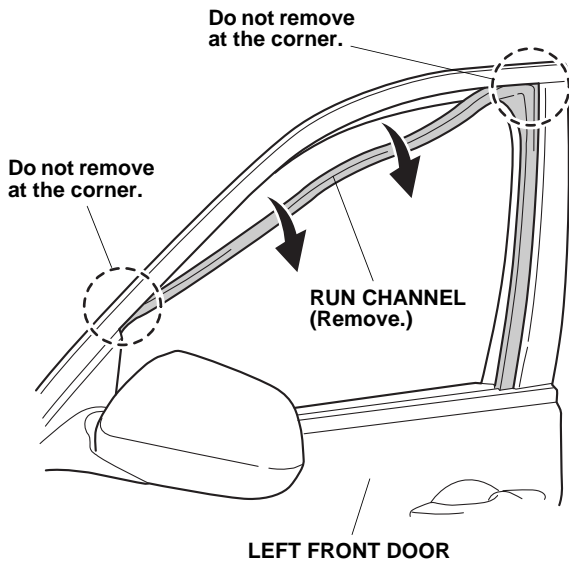

3. Position bracket B on the door sash as shown, then reinstall the run channel in this area.

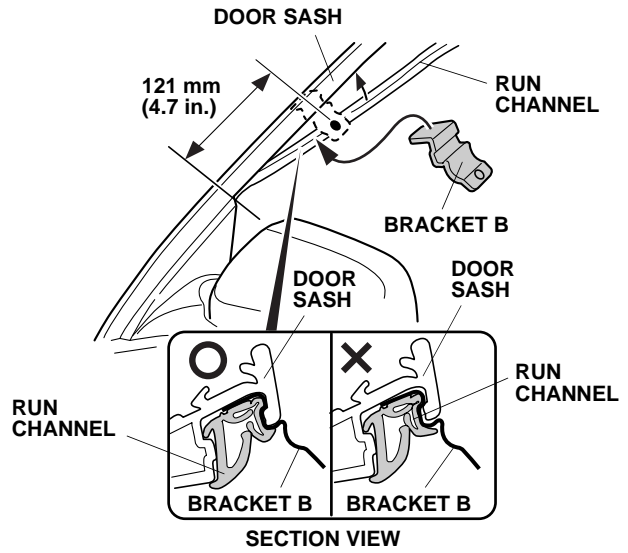

4. Position bracket D on the door sash as shown, then reinstall the run channel in this area.

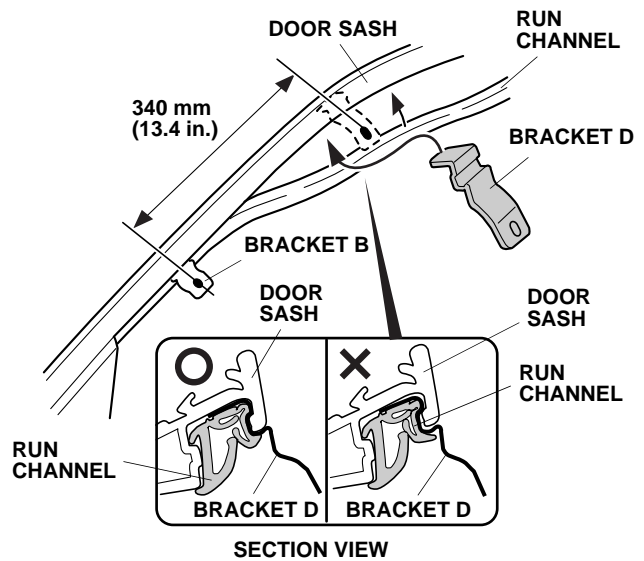

- Position bracket C on the door sash as shown, then reinstall the run channel.

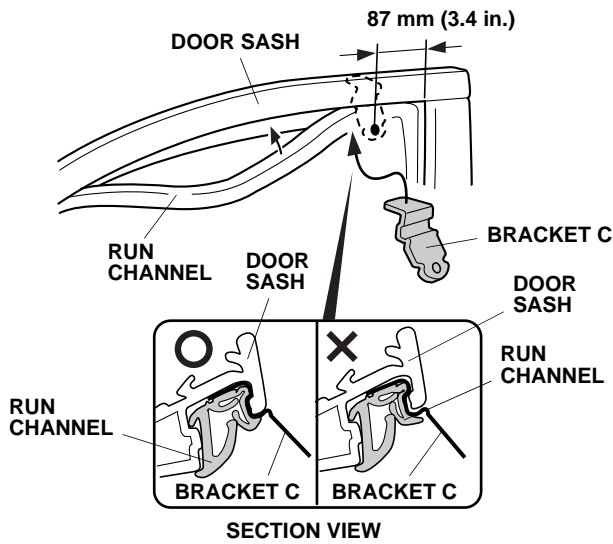

- Peel back approximately 40-50 mm (1/2 to 2 in.) of adhesive backing from each adhesive tape, and tape the ends to the front surface of the left front door visor.

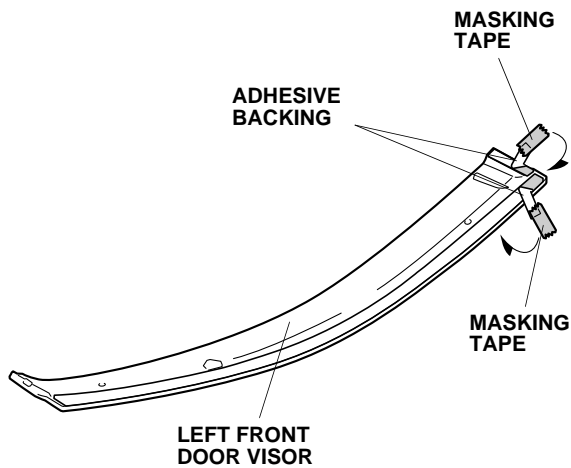

- Using isopropyl alcohol on a shop towel, clean the door sash where the left front door visor will attach.

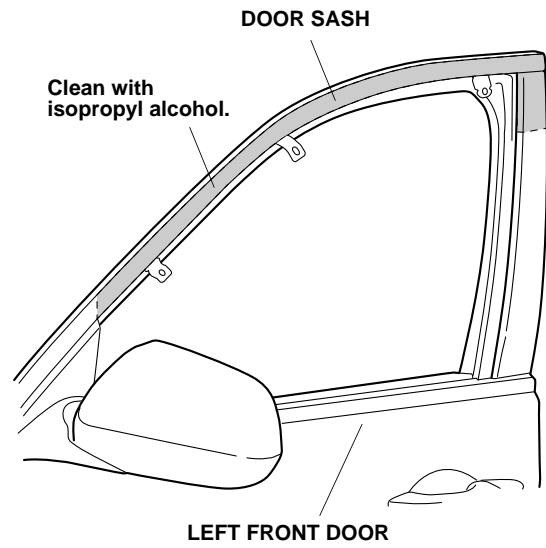

- Position the left front door visor on the door sash. Push the front retaining bracket behind the door mirror base as shown.

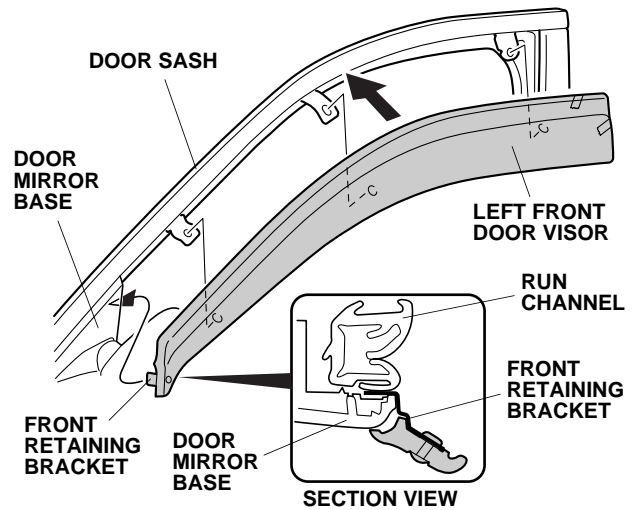

- Adjust the position of bracket B and install the front clip.

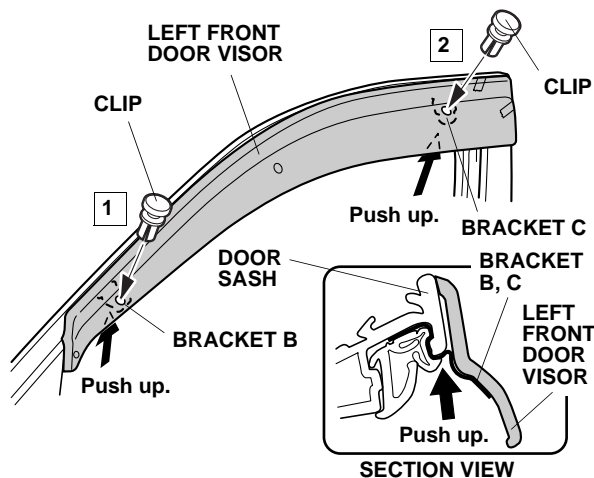

- Adjust the position of bracket C and install the rear clip. There should be no clearance between the bracket and the door sash.

- Adjust the door visor so there is 5 mm (0.2 in.) between the edge of the left front door visor and the outside edge of the door sash.

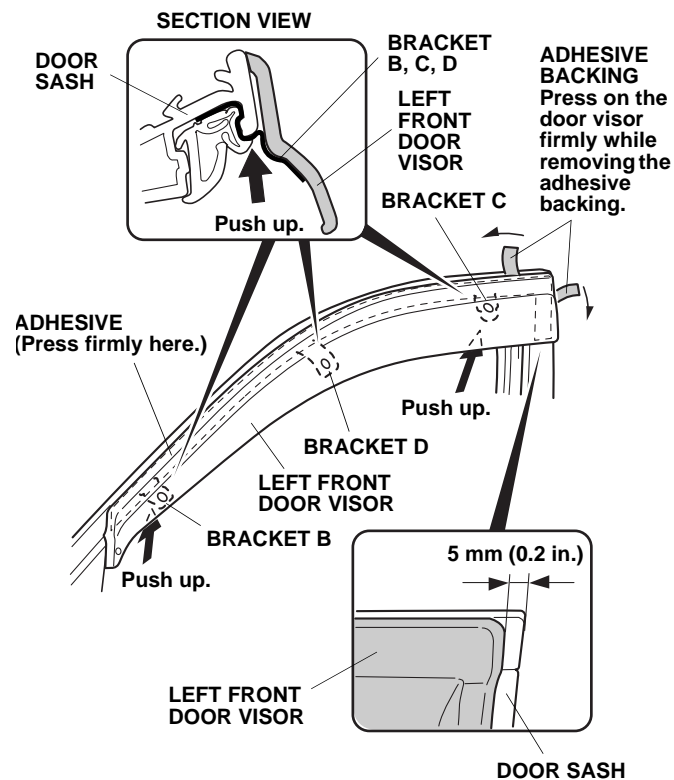

- Press the left front door visor firmly against the door. Starting from the rear edge of the door visor and working forward, remove the two adhesive backings and attach the adhesive tape on the left front door visor to the door sash. With a soft towel around your finger, push up the brackets so there is no clearance between the bracket and the door sash.

13. Using one clip and one washer, secure the left front door visor to bracket D as shown.

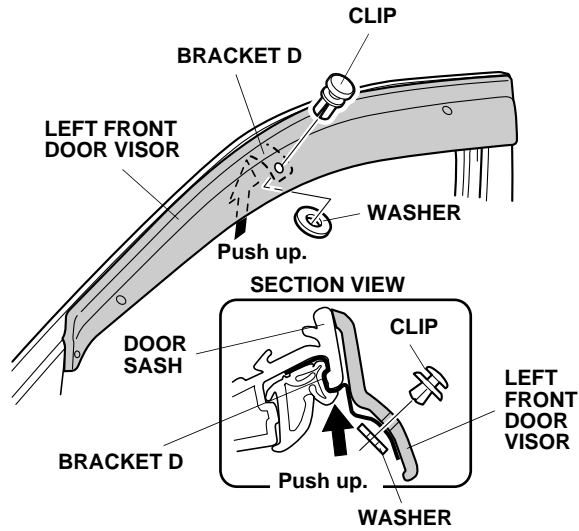

### Installing the Rear Door Visors

14. Fully lower the left rear door glass.  
 15. Remove the run channel as shown. Do not remove the run channel at the corners.

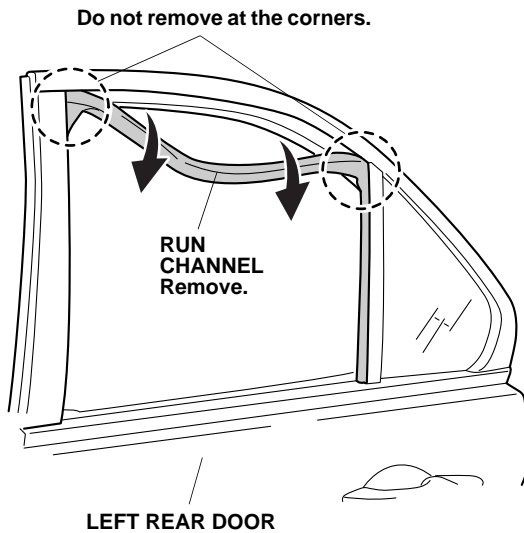

16. Position bracket B on the door sash as shown, then reinstall the run channel around the bracket.

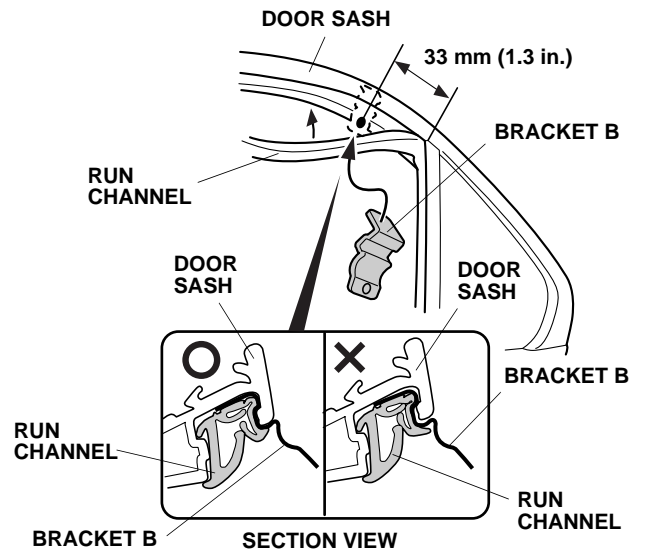

17. Position bracket C on the door sash as shown, then reinstall the run channel.

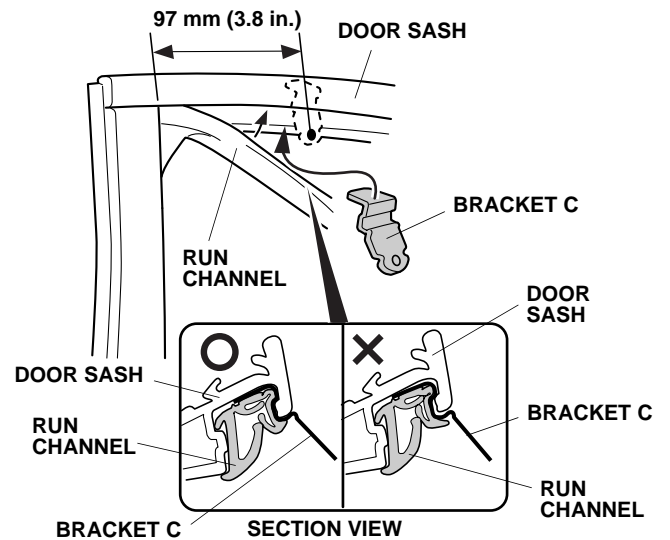

18. Peel back approximately 40–50 mm (1.5–2 in.) of adhesive backing from each adhesive tape, and tape the ends to the front surface of the left rear door visor.

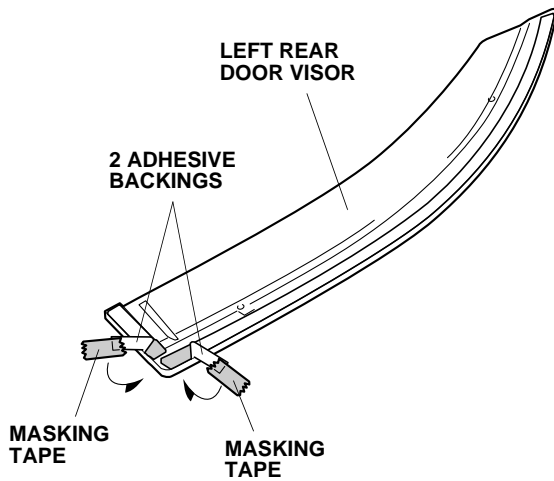

19. Using isopropyl alcohol on a shop towel, clean the door sash where the left rear door visor will attach.

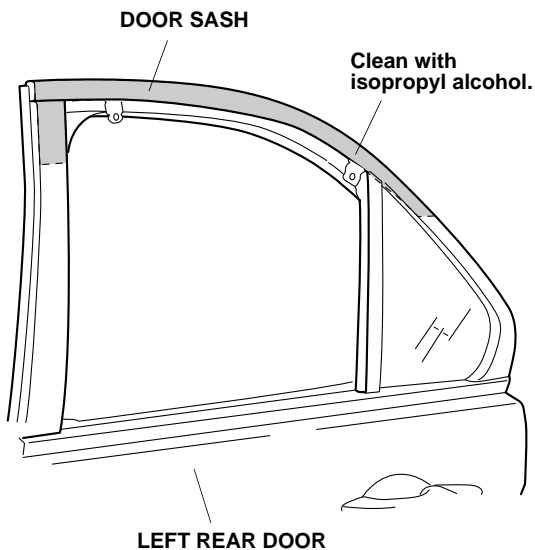

20. Position the left rear door visor on the door sash.

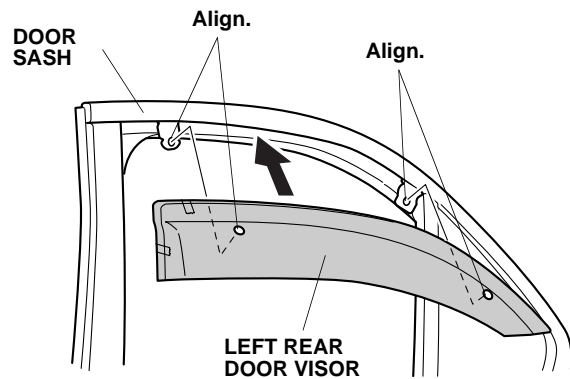

21. Adjust the position of bracket B and install the rear clip.

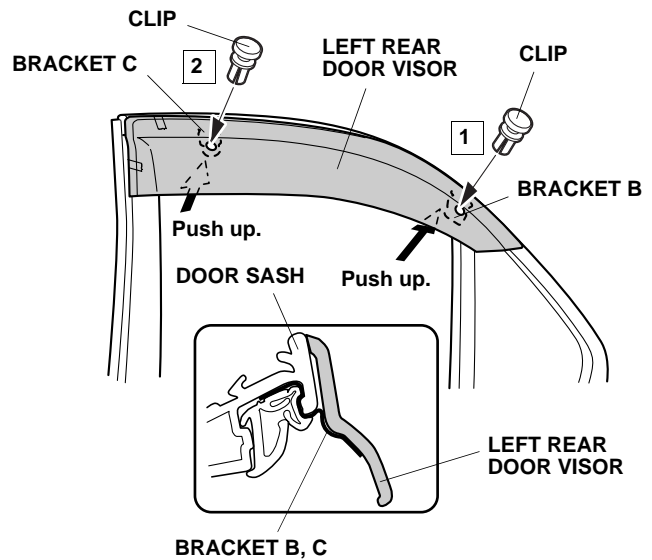

22. Adjust the position of bracket C and install the front clip. There should be no clearance between the bracket and the door sash.

23. Adjust the visor so there is 5 mm (0.2 in.) between the edge of the left rear door visor and the outside edge of the door sash.
24. Press the left rear door visor firmly against the door. Starting from the rear edge of the door visor and working forward, remove the two adhesive backings, and attach the adhesive tape on the door visor to the door sash. With a soft towel around your finger, push up the brackets so that there is no clearance between the bracket and the door sash.

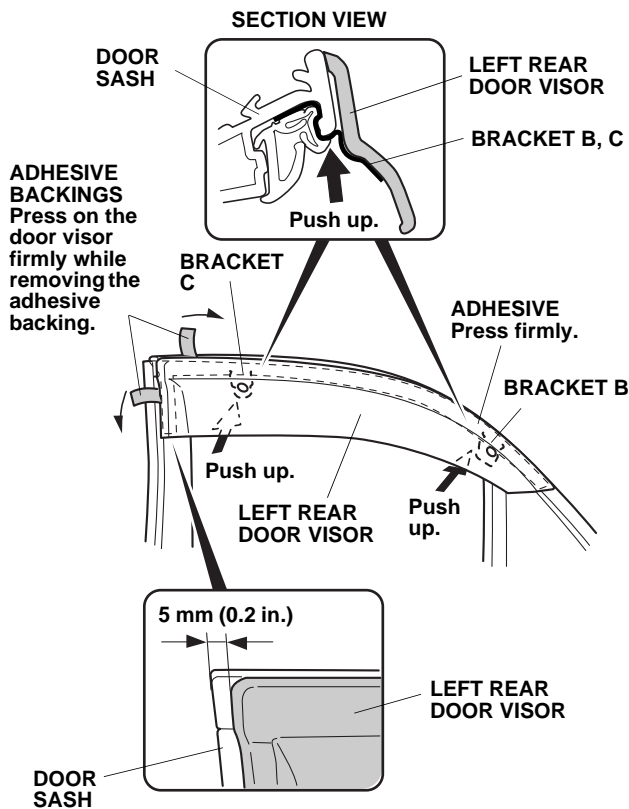

25. Repeat steps 1 through 24 to install the door visors on the right side of the vehicle.

26. Start the engine.
27. Using the power window switch, fully raise the windows, and check that the run channel is not pinched.
28. Using the master power window switch, open and close each window several times to seat the run channel.

### Resetting the Power Window Control Unit

#### NOTE:

- Do each bullet in step 32 within 5 seconds of each other.
  - The front passenger's power window must be reset from the front passenger's power window switch.
  - With front passenger's power window AUTO UP/AUTO DOWN function.
29. Turn the ignition switch to ON (II).
  30. Move the power window all the way down by using the power window DOWN switch.
  31. Open the driver's door.
  32. Do the following three times before going to step 33:
    - Turn the ignition switch to LOCK (0).
    - Push and hold the power window DOWN switch.
    - Turn the ignition switch ON (II).
    - Release the power window DOWN switch.
  33. Confirm that AUTO UP no longer works. If AUTO UP still works, go back to step 30.
  34. Move the power window all the way down using the power DOWN switch.
  35. Pull up and hold the power window UP switch until the power window is all the way up, then continue to hold the switch for 1 second.
  36. Confirm that the power window control unit is reset by using the power window AUTO UP and AUTO DOWN function.
    - If the power still does not work in AUTO, repeat the resetting several times, paying close attention to the 5 second time limit between steps.
    - If it still does not work, go to B-CAN System Diagnoses Test Mode A in the service manual.

### USE AND CARE

Clean the door visor with mild detergent and water. Do not use organic solvents (thinner, benzene, alcohol, etc.) or cleaners containing any abrasive material.