



ACURA

INSTALLATION INSTRUCTIONS

Accessory

19" ALUMINUM WHEEL

Application

2011 RDX

Publications No.

BII 43520

Issue Date

JULY 2010

PARTS LIST

Aluminum wheel
(The illustration may differ from the actual wheel.)

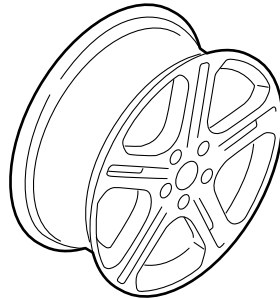

Wheel center cap
(The illustration may differ from the actual center cap.)

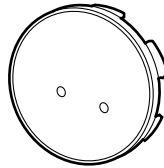

Center cap emblem

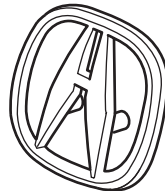

2 Push nuts

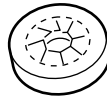

Tire pressure information label



Important information

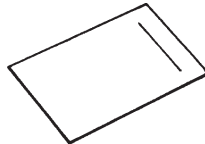

Wheel cleaning information
(Give this information to your client.)

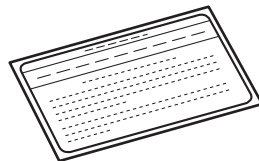

TPMS information
(Give this information to your client.)

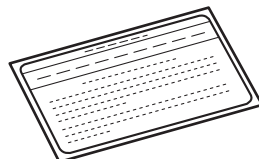

Parts for TPMS sensor assembly

Tire pressure sensor assembly

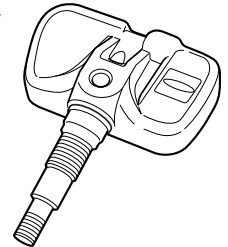

Washer



Valve cap



Valve nut



TOOLS AND SUPPLIES REQUIRED

Ratchet

11 mm Socket

Torque wrench

Isopropyl alcohol

Shop towel

SPECIFICATIONS

Rim size	19 x 8 J (offset 45)	
Tire size	245/45R19 98Y	
Bolt hole PCD	114.3 (5 holes)	
Tire pressure	Front	33 psi (230 kPa, 2.3 kgf/cm ²)
	Rear	33 psi (230 kPa, 2.3 kgf/cm ²)

INSTALLATION

Client Information: The information in this installation instruction is intended for use only by skilled technicians who have the proper tools, equipment, and training to correctly and safely add equipment to your vehicle. These procedures should not be attempted by “do-it-yourselfers.”

NOTE:

- This aluminum wheel is designed for use on vehicles equipped with TPMS (Tire Pressure Monitoring System).
 - This aluminum wheel is equipped with a TPMS sensor. See the service manual for the tire replacement procedure and TPMS sensor installation procedure.
 - Install the correct size tire (245/45R19 98Y).
 - The wheel nut torque is 108 N·m (80 lb-ft).
 - Be careful not to damage the wheel center cap when installing the emblem.
 - The center cap emblem kit should be installed only if the ambient air temperature is 60°F (15°C) or above.
 - To allow the adhesive to cure, do not wash the vehicle for 24 hours.
1. Before installing the tire pressure sensor, clean the mating surface on the sensor and the aluminum wheel.

2. Install the tire pressure sensor to the aluminum wheel and loosely install the valve nut. Make sure the pressure sensor is resting on the wheel.

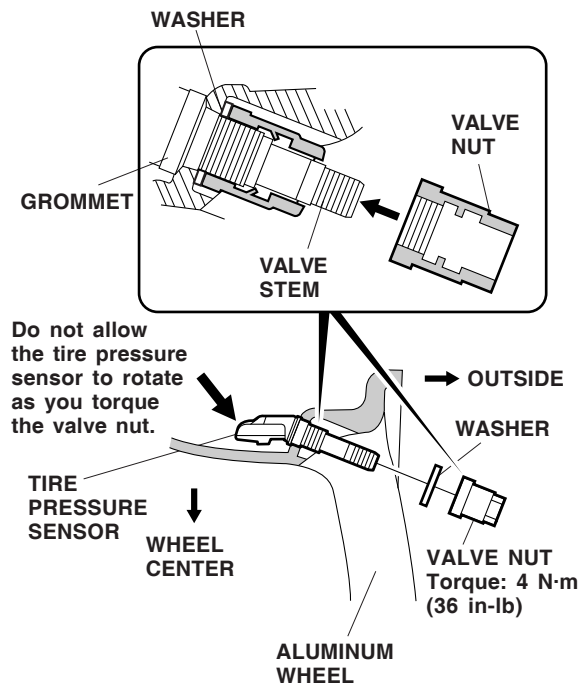

3. Torque the valve nut to 4 N·m (36 in-lb) while holding the tire pressure sensor toward the wheel. You may hear a snap or pop as you tighten the nut—this is normal.

NOTE:

- Do not reuse a grommet that has already been torqued. If you do, the valve stem may leak.
 - Do not use pneumatic or electric tools on the valve nut.
 - Tightening the nut above the specified torque can damage the grommet.
 - Make sure that there is no gap between the sensor and the wheel.
4. Install the tires according to the procedure in the service manual. Be careful not to damage the new sensor.

5. Using isopropyl alcohol on a shop towel, clean the area where the center cap emblem will attach.
6. Remove the adhesive backing from the center cap emblem.

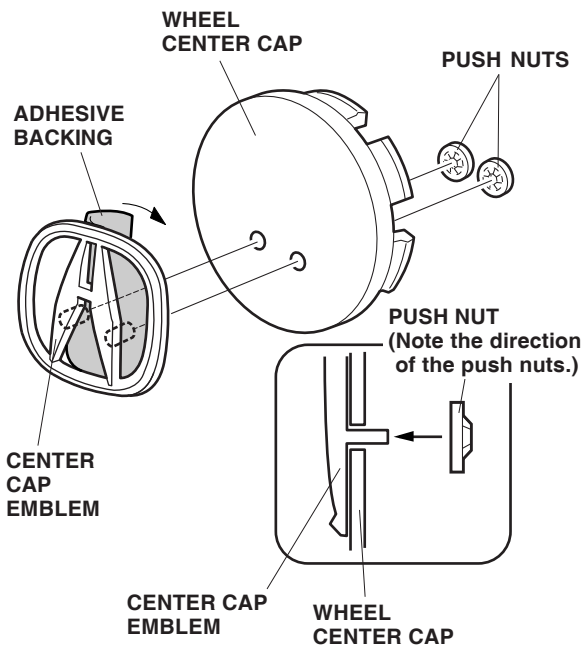

7. Attach the center cap emblem to the wheel center cap by aligning its pins with the holes in the wheel center cap. After attaching, hold the emblem firmly against the wheel center cap with the palm of your hand for 30 seconds.
8. Slide the push nuts onto the pins. Note the direction of the push nuts.
9. Install the cap onto the wheel.

10. Open the driver's door. Using isopropyl alcohol, clean the tire pressure information label on the doorjamb. Remove the adhesive backing from the new information label and attach it over the old label.

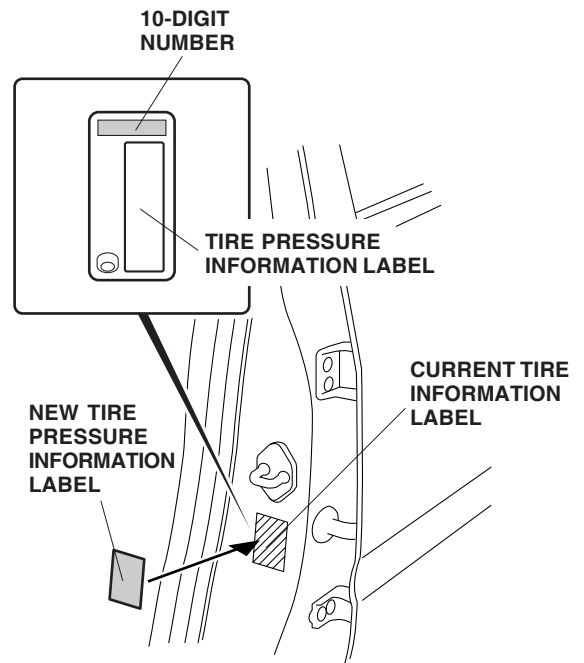

11. Install the wheels on the vehicle and torque them to 108 N·m (80 lb-ft). Put the valve stems at the 12 o'clock position before lowering the vehicle to the ground.

- Do the sensor ID learning procedure (see page 4).

SENSOR ID LEARNING

NOTE: To ensure that the control unit memorizes the correct IDs, park the vehicle with the new sensor must be at least 3 m (10 ft) from any other TPMS pressure sensor not installed on that vehicle.

- Connect the HDS to the vehicle, make sure the correct VIN is populated, and enter the mileage.
- At the System Selection Menu, click TPMS.
- At the Mode Menu, click DTC and clear any stored codes.
- Go back to the Mode Menu, click Sensor ID Learning and follow the screen prompts.

NOTE: If the sensor ID learning fails, have an assistant drive the vehicle under 10 mph while you redo the ID learning procedure. The TPMS control unit should learn all four sensor IDs. If one or more of the sensor IDs are not learned, then go to normal troubleshooting in the service manual before continuing. If all four sensor IDs are learned, go to step 17.

LOW TIRE PRESSURE WARNING THRESHOLD REPROGRAMMING

- From the TPMS Mode Menu, click on Threshold Rewriting.
- Select "Reprogramming for accessory tires."
- When the HDS says "Do you want to rewrite the threshold data?" click "YES."
- When "Please enter the tire information code of new tires" is shown, click the Keyboard icon.
- Enter the 10-digit tire information code printed on the new tire pressure information label, then click the check icon.
- Check that the tire pressure shown on the HDS matches the one on the new tire pressure information label, then click the "YES" button.
- Check that the current air pressure setting shown on the HDS is correct and "Reprogramming the threshold data for non-standard tires has completed successfully" is shown.
- Write the tire pressure indicated on the HDS in the service history page for Acura Accessory Wheels, then click the check icon.

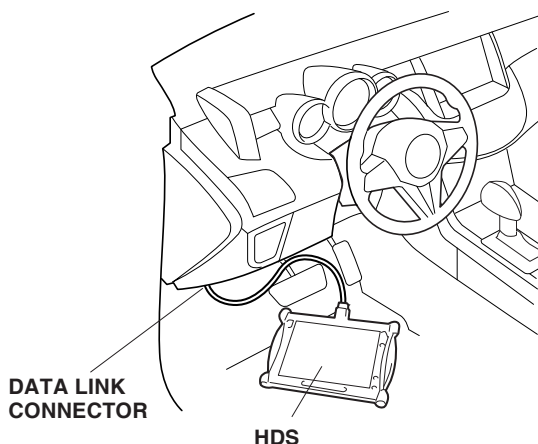

TIRE PRESSURE INFORMATION LABEL

TIRE AND LOADING INFORMATION	
The combined weight of occupants and cargo should never exceed 3500 lb or 1588 kg.	
SEATING CAPACITY TOTAL 5 FRONT 2 REAR 3	
TIRE SIZE	COLD TIRE PRESSURE
FRONT 245/45R19 98Y	230kPa, 33PSI
REAR 245/45R19 98Y	230kPa, 33PSI
SPARE T165/80R17 104M	420kPa, 60PSI
SEE OWNER'S MANUAL FOR ADDITIONAL INFORMATION	
STK2302302	

10-DIGIT NUMBER

25. Sign on the service history page for Acura Accessory Wheels, according to the procedure on page 5.
26. Write the tire size, tire pressure, HDS version, dealer name, technician's signature, and date in the service history page for Acura Accessory Wheels page, and attach the page to the vehicle's service history booklet.

NOTE:

- Be sure to explain the changes made in the service history booklet to your client before

delivering the vehicle.

- Be sure to give the wheel cleaning information and TPMS information to your client.

STANDARD TIRE PRESSURE PROGRAMMING

If the original equipment (standard) wheels are reinstalled on the vehicle, the low pressure warning threshold must be restored to the factory setting.

To return the TPMS programming from the inch-up wheel to the standard wheel, do the following:

1. Connect the HDS to the vehicle, make sure the correct VIN is populated, and enter the mileage.
2. At the System Selection Menu, click TPMS.
3. At the Mode Menu, click the DTC and clear any stored codes.
4. Go back to the Mode Menu, click Threshold Rewriting.
5. Click on "Reprogramming for standard tires" and follow the screen prompts
6. After programming, write the measured tire pressure in the important information, then click the check button.
7. Attach the standard tire pressure information label over the old label in the driver's doorjamb.

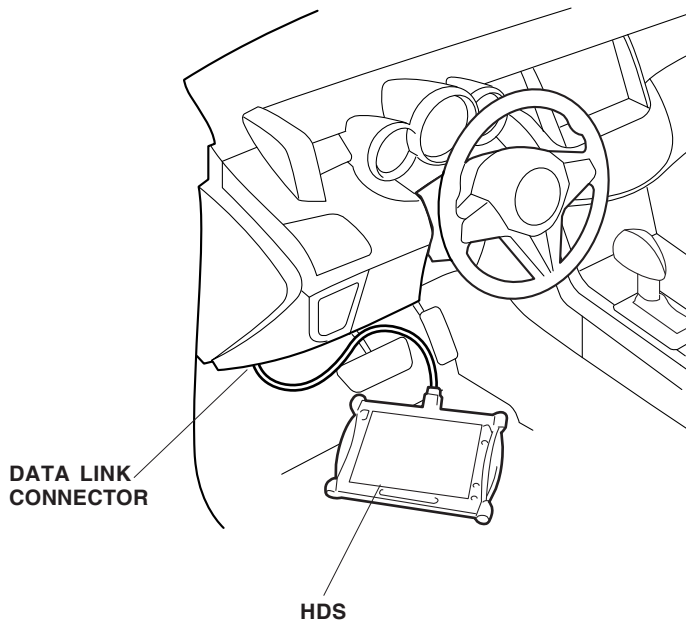

8. After programming, sign on the service history page for Acura Accessory Wheels, according to the procedure shown on page 5.

THRESHOLD DATA CHECK

If you are unsure of where the low pressure warning threshold is set, it can be checked by using Threshold Data Check.

Check the low tire pressure warning threshold programming by doing the following:

1. Connect the HDS to the vehicle, make sure the correct VIN is populated, and enter the mileage.
2. At the System Selection Menu, click TPMS.
3. Click on Threshold Rewriting.
4. Click on Threshold Data Check.

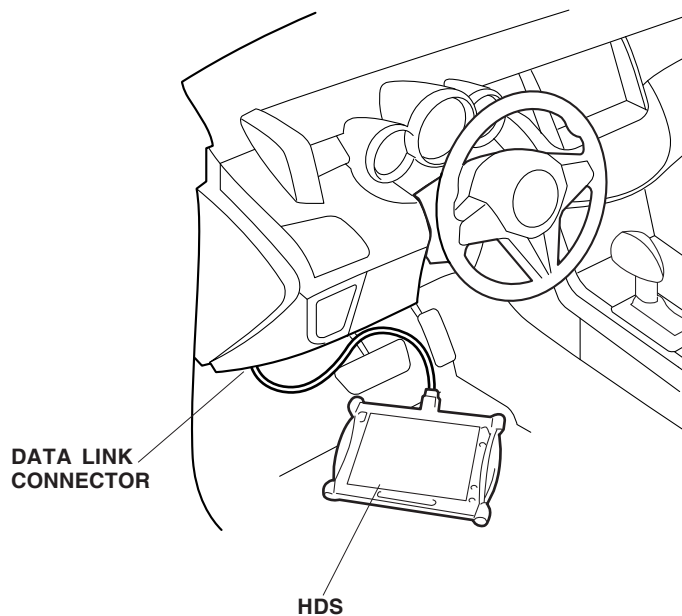

TPMS UNIT REPLACEMENT

If the TPMS control unit is replaced and the vehicle has inch-up wheels, the low pressure sensor threshold must be changed. Once the TPMS control unit is installed, redo sensor ID learning and low tire pressure warning threshold reprogramming (see page 4)