



INSTALLATION INSTRUCTIONS

Accessory
REMOTE CONTROL ENGINE STARTER

Application
2010 TL (BASE MODEL)

Publications No.
BII 42534
Issue Date
AUG 2009

PARTS LIST

Remote Control Engine Starter Unit Kit P/N 08E91-TK4-200A

Transmitter

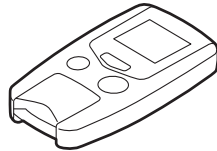

Control unit

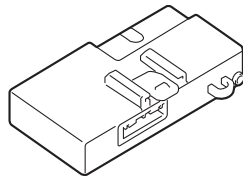

Antenna

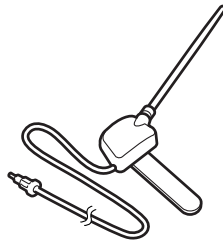

Key ring



Protective tape



Caution label

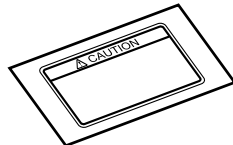

Fuse label

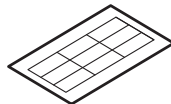

Accessory User's Information Manual

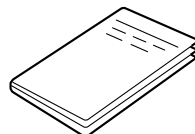

Quick Start Guide

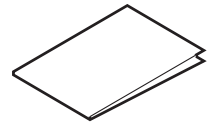

Remote Control Engine Starter Attachment Kit P/N 08E92-TK4-200B

Engine starter harness

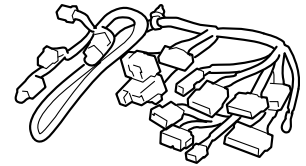

Control unit bracket

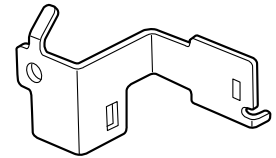

2 Relays

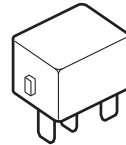

21 Wire ties

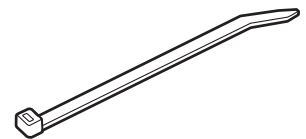

6 Urethane tapes

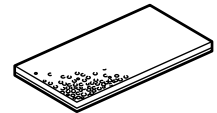

Template

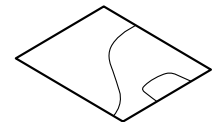

A-Pillar clip



TOOLS AND SUPPLIES REQUIRED

Phillips screwdriver
Flat-tip screwdriver
Small flat-tip screwdriver
Ratchet
10 mm and 12 mm Sockets
10 mm Combination wrench
Diagonal cutters
Isopropyl alcohol
Shop towel
Tape measure
Scissors
Rubber mallet
HDS (Honda Diagnostic System)
Masking tape
2 Pairs of needle nose pliers
Plastic Trim Tool (T/N SILTRIMTL10)
Heavy gloves

Illustration of the Engine Starter Installed in the Vehicle

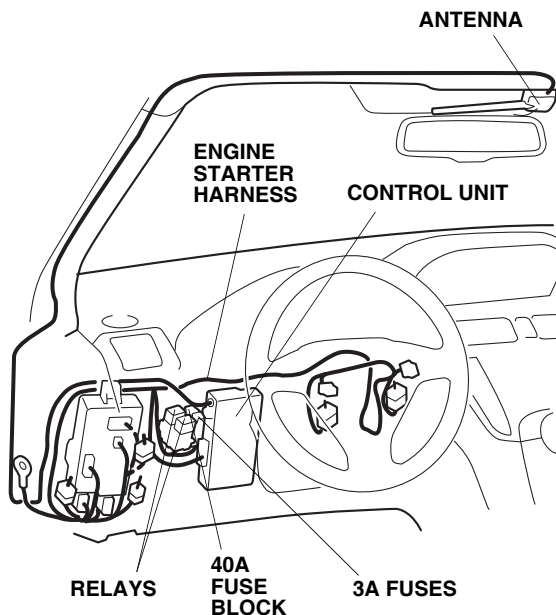

INSTALLATION

Client Information: The information in this installation instruction is intended for use only by skilled technicians who have the proper tools, equipment, and training to correctly and safely add equipment to your vehicle. These procedures should not be attempted by “do-it-yourselfers.”

NOTE: The antenna should only be installed if the ambient air temperature 15°C (60°F) or above.

1. Make sure you have the anti-theft codes for the audio and navigation system (if equipped), then write down the audio presets.

Setting the Control Unit

- Using a small flat-tip screwdriver, adjust the switches on the (accessory) control unit to the locations shown.

NOTE:

- The switches must be adjusted before the control unit is plugged in.
- If the switch setting is not correct, the remote engine starter will not operate correctly.
- If adjusting the switches with the control unit installed in the vehicle, touch the metal part of the screwdriver to any metal part of the vehicle to discharge any static electricity.
- If you change the switch settings with the unit connected, you must disconnect the unit then reconnect it before the settings change.

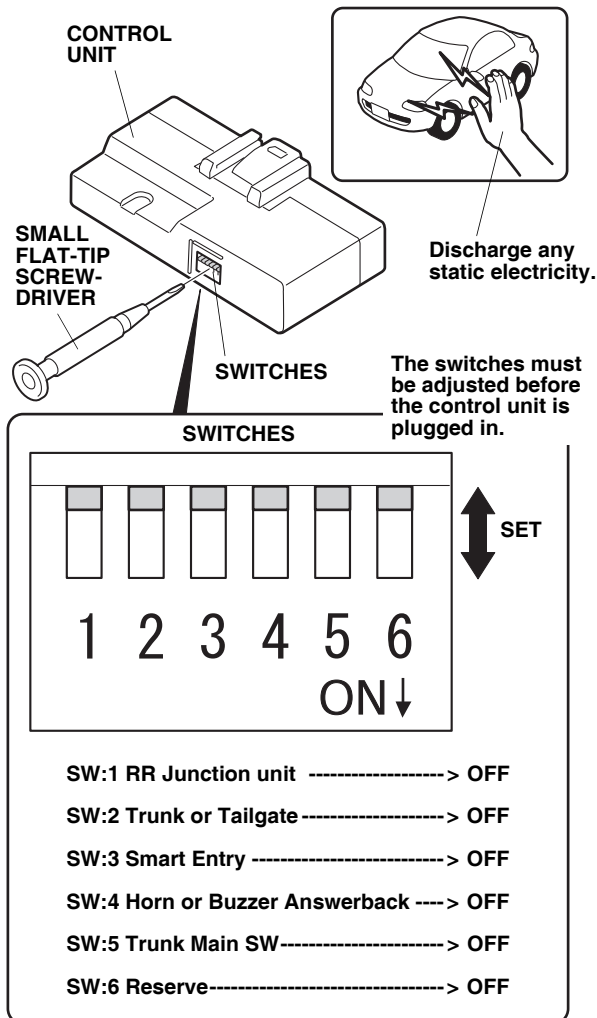

- Using isopropyl alcohol on a shop towel, clean the control unit where the protective tape will attach. Remove the adhesive backing, and attach the protective tape to the control unit over the switch opening.

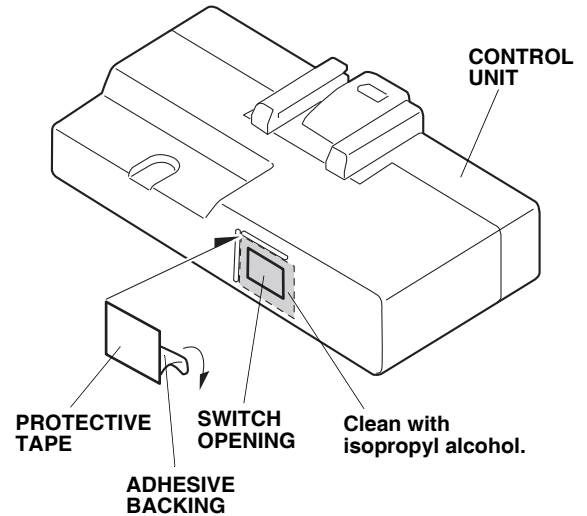

- Open the hood, and remove the front engine cover (four clips and two hooks).

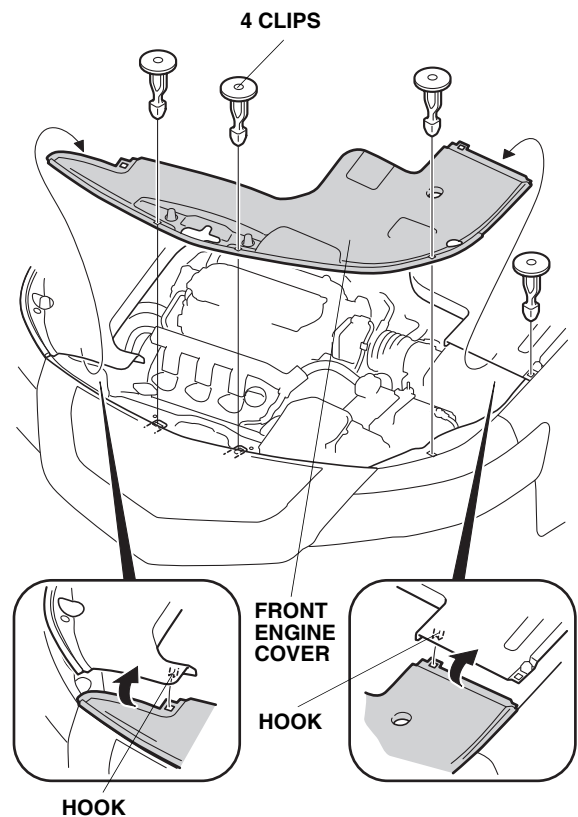

- Disconnect the negative cable from the battery.

6. Lower the tilt lever and pull the steering wheel out. Remove the two lower self-tapping screws and the lower screw.

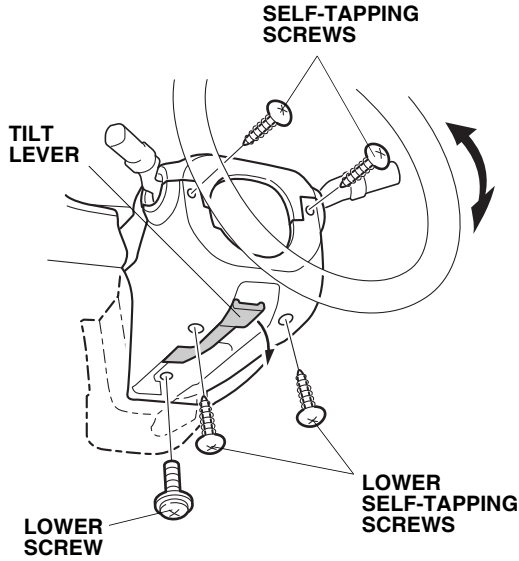

7. Turn the steering wheel as necessary to access each self-tapping screw, and remove the two self-tapping screws.

8. Remove the upper steering column cover and the lower steering column cover:
- Starting with the left side, use a small flat-tip screwdriver to push in to release the tab, then push in on the side of the upper steering column cover in the area shown to release the rear tab.
 - Shift the column covers to the right, and repeat the same procedure.
 - Release the four hooks, and remove the upper steering column cover and the lower steering column cover.

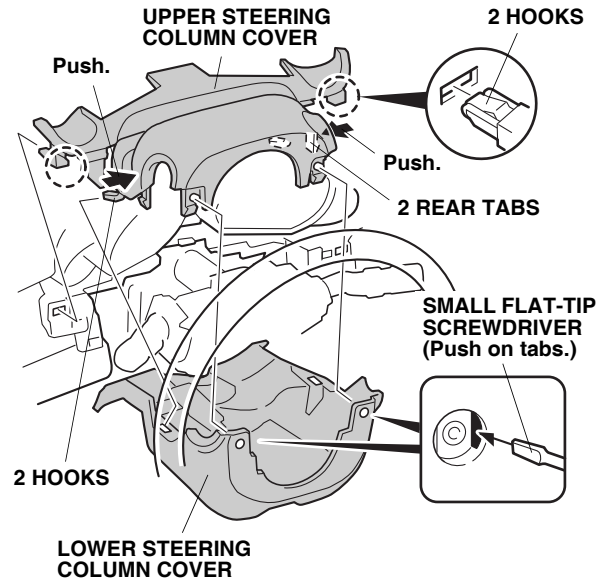

9. Remove the roof console:
 - Open the sunglass holder, and remove two self-tapping screws.
 - Release the two clips, and pull the roof console toward you.
 - Unplug the vehicle connectors to remove the roof console.

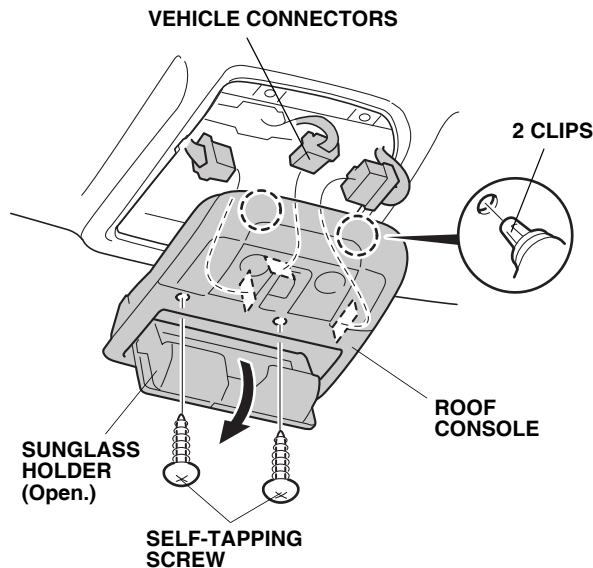

10. Turn the sunvisor holder 90°, and remove the two sunvisor holders.

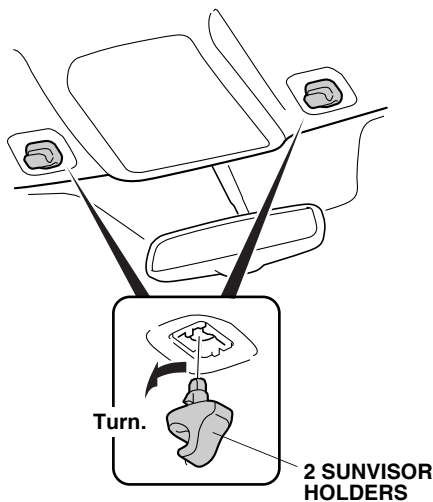

11. Remove the left sunvisor.
 - Turn the left sunvisor toward the driver's seat.
 - Locate the slot in the sunvisor holder, and insert a flat-tip screwdriver into the slot. Push in and hold the retaining tab.
 - While holding the retaining tab, rotate the visor toward the door to remove it.
 - Unplug the vanity mirror light connector.

NOTE: If the retaining tab did not stay pushed in, return the left sunvisor to its original position and repeat the steps above.

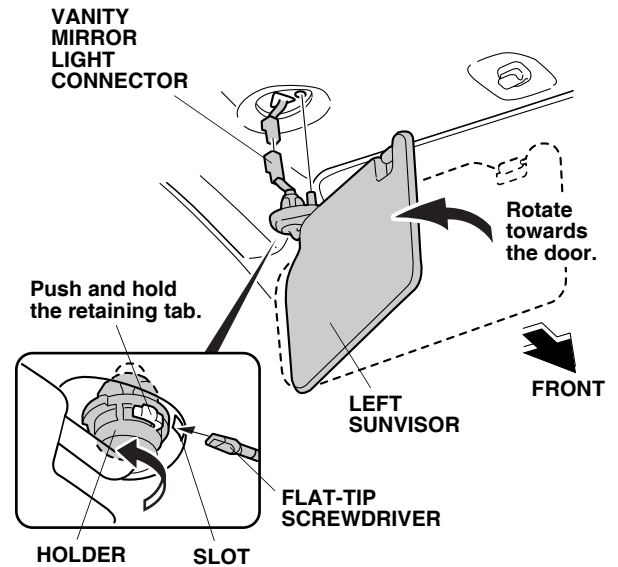

12. Pull away the door opening trim from the left front A-pillar trim.

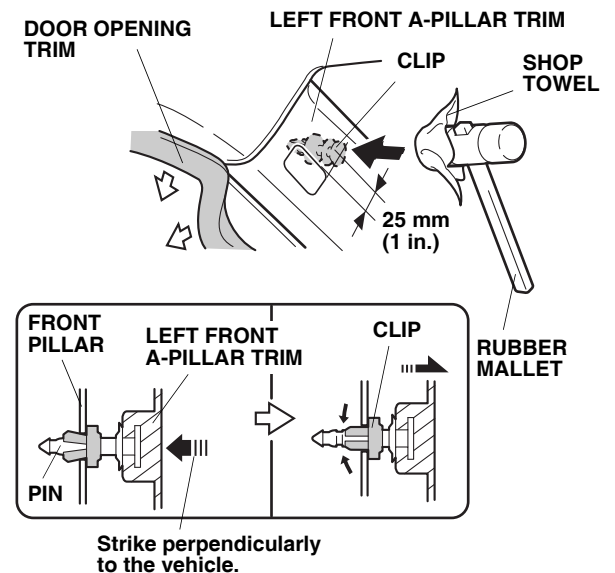

13. Using a rubber mallet and a shop towel, gently tap the left front A-pillar trim at the position shown to release the clip.

14. Pull away the door opening trim, and remove the left front A-pillar trim (one clip, and unplug the vehicle connector).

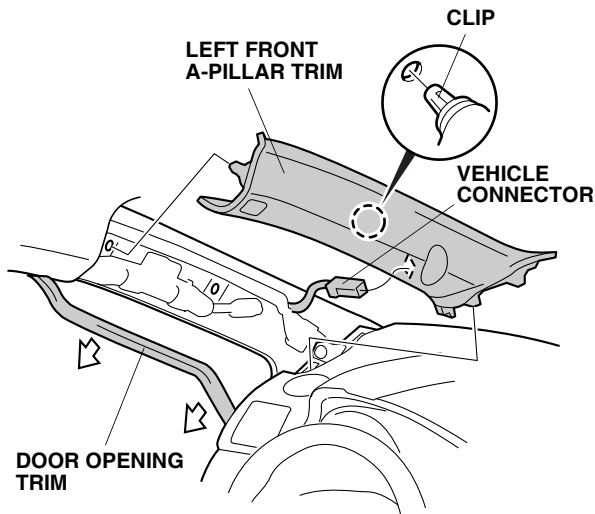

15. Remove and discard the clip from the left front A-pillar trim, and install a new A-pillar clip (supplied) on the left front A-pillar trim.

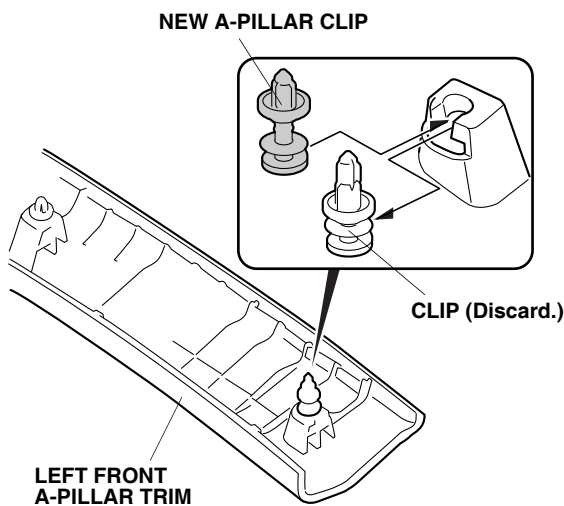

16. Remove the left dashboard side cover (four clips and four hooks).

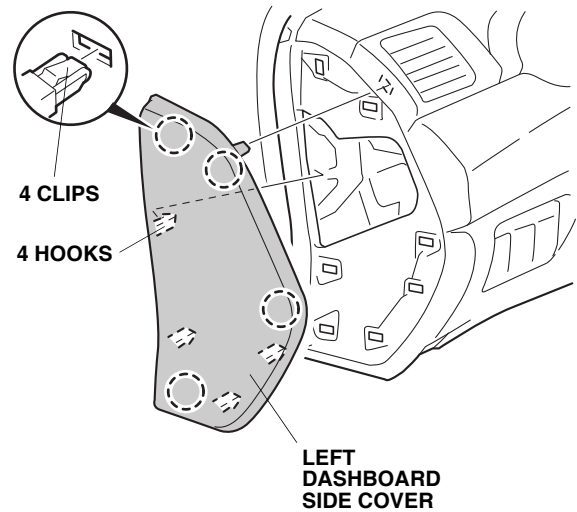

17. Remove the driver's dashboard under cover:

- Turn the knob counterclockwise.
- Release the two clips and one pin, then pull the driver's dashboard under cover toward you.
- Unplug the vehicle connector, and release the harness clip to remove the driver's dashboard under cover.

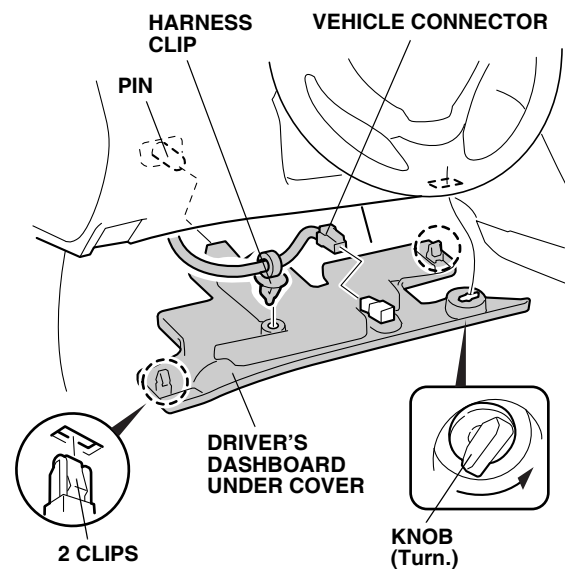

18. Remove the left front door sill trim (four clips and three retaining tabs).

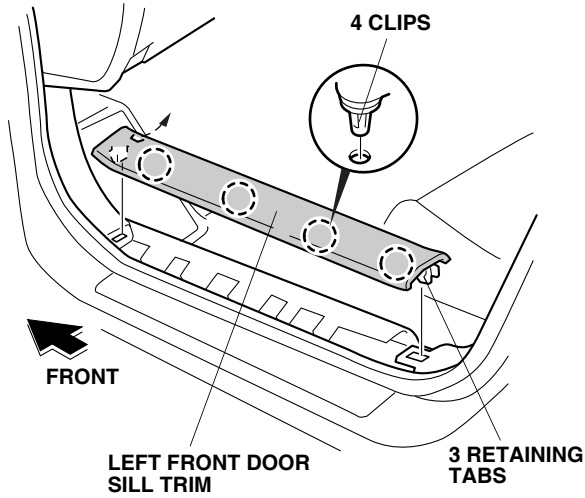

19. Pull away the door opening trim, and remove the left kick panel (two clips).

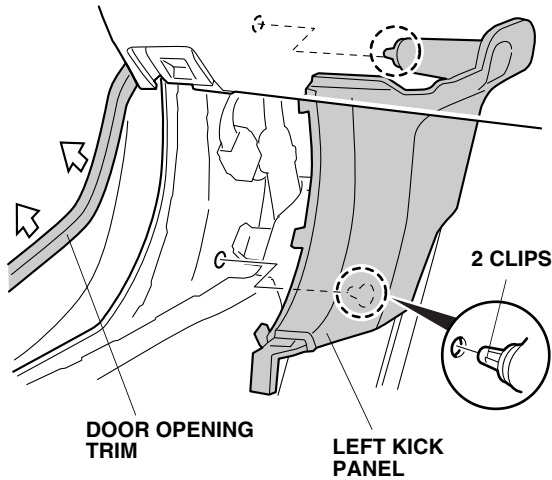

Installing the Antenna

20. Using scissors, cut out the template.

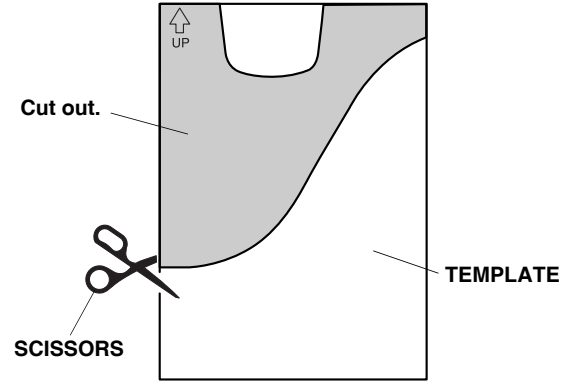

21. Using masking tape, attach the template to the windshield. Align with the black ceramic as shown.

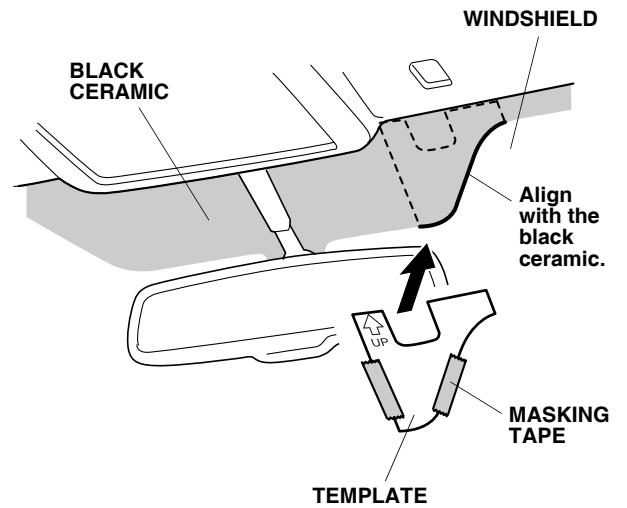

22. Get the antenna. Bend the antenna plate according to the full scale drawing shown. Use two pairs of needle nose pliers as shown.

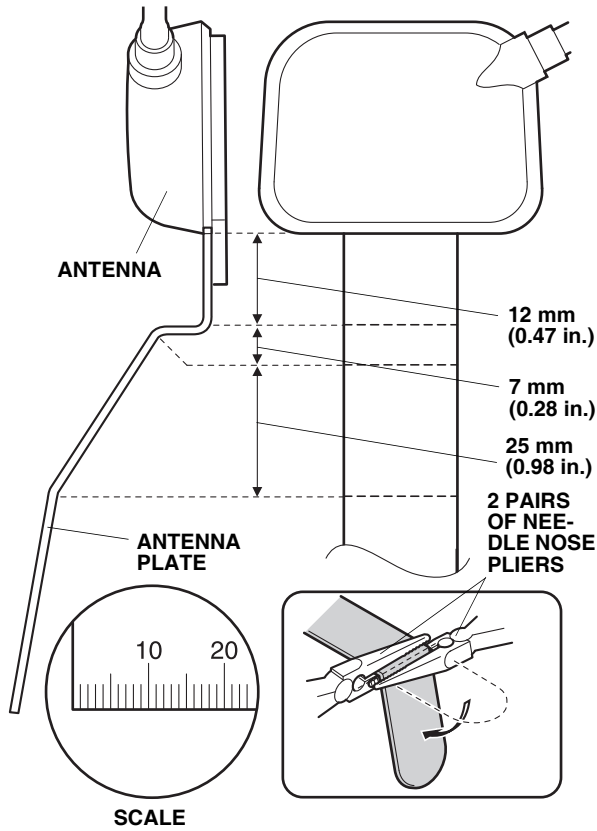

23. Starting near the antenna end of the cable, wrap three urethane tapes around the antenna cable at the measurements shown.

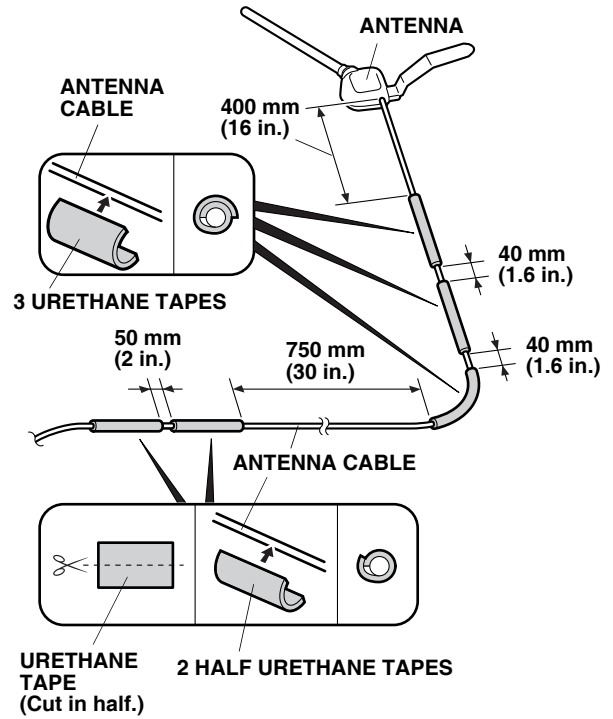

24. Using scissors, cut one urethane tape in half. Wrap the two halves of the urethane tape around the antenna cable at the measurements shown.

25. Using isopropyl alcohol on a shop towel, clean the area where the antenna will attach.

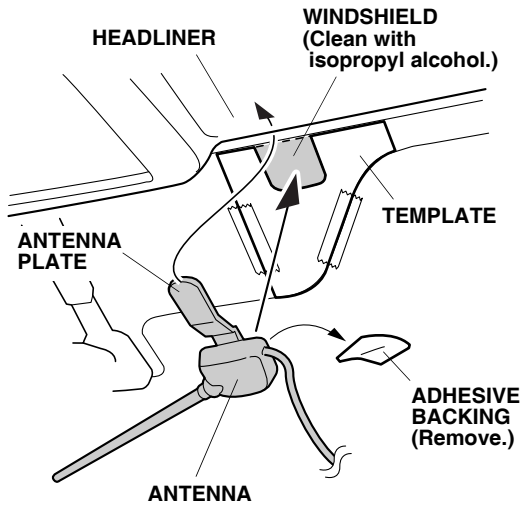

26. Remove the adhesive backing from the antenna. Insert the antenna plate over the headliner, align the antenna with the template, and attach it to the windshield.
- Make sure the antenna attaches firmly to windshield.
27. Remove the template.
28. Route the antenna cable towards the driver's side of the vehicle. Gently pull down the headliner, and tuck the antenna cable under it. Be careful not to crease the headliner.

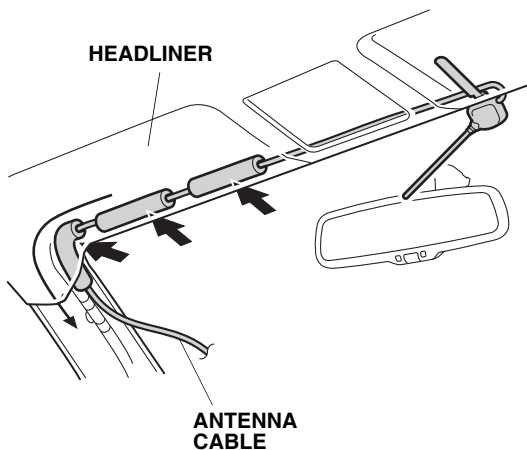

29. Using isopropyl alcohol on a shop towel, clean the area where the urethane tapes will attach.

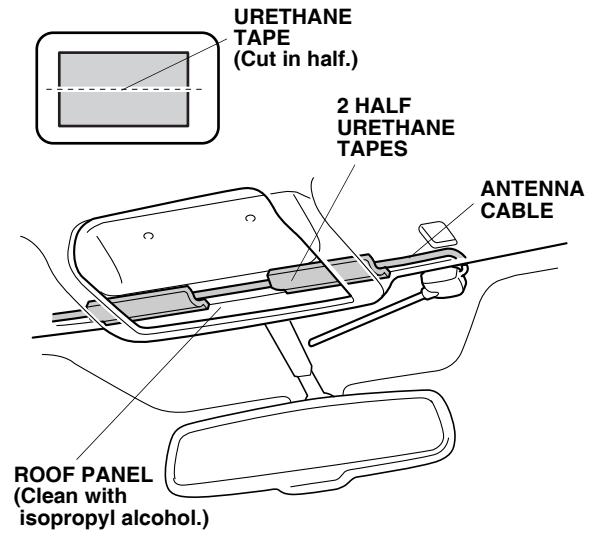

30. Using scissors, cut one urethane tape in half. Secure the antenna cable to the roof panel with the two halves of urethane tape.
31. Secure the antenna cable to the vehicle harness with six wire ties.

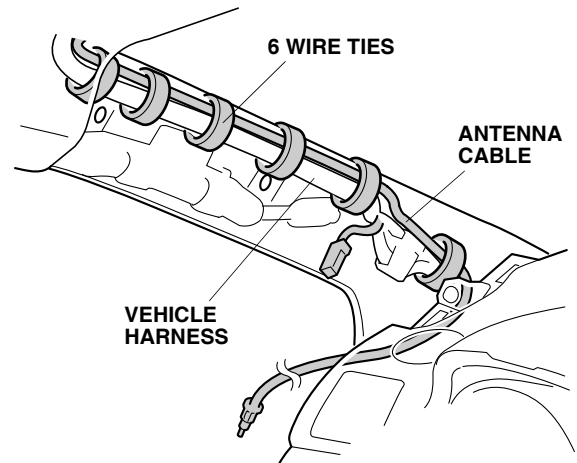

32. Pull away the door opening trim from the left front A-pillar. Route the antenna cable down next to the dashboard, and tuck the antenna cable between the left front A-pillar and the dashboard. Reinstall the door opening trim.

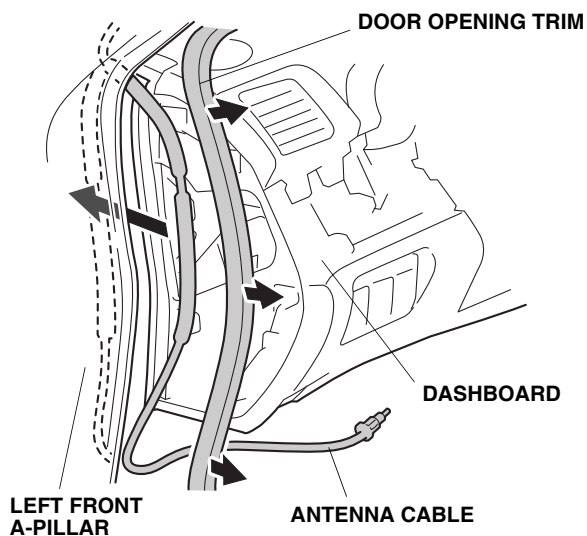

33. Route the antenna cable along the vehicle harness as shown.

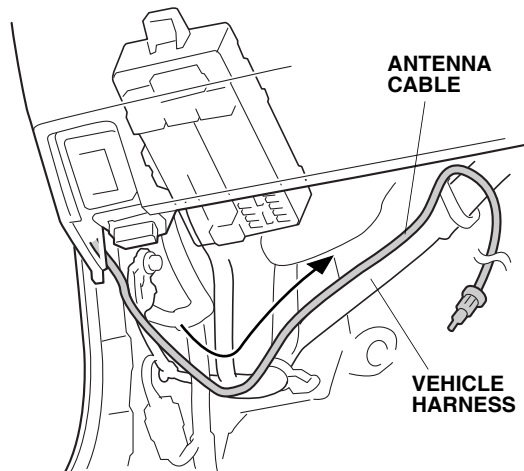

Routing the Engine Starter Harness

34. Using isopropyl alcohol on a shop towel, clean the area where the fuse labels will attach.

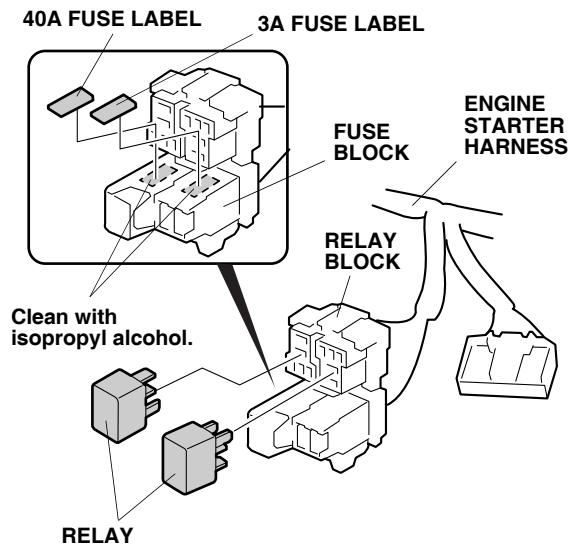

35. Attach the 40A and 3A fuse labels to the engine starter harness fuse block.
36. Install the two relays on the engine starter harness relay block.
37. Plug the antenna terminal into the control unit.

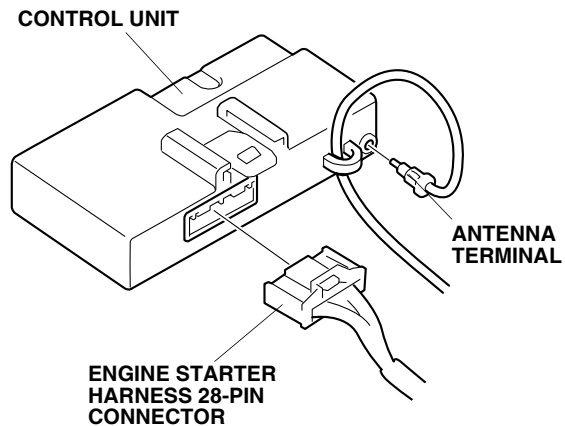

38. Plug the engine starter harness 28-pin connector into the control unit.

39. Install the control unit bracket to the control unit.

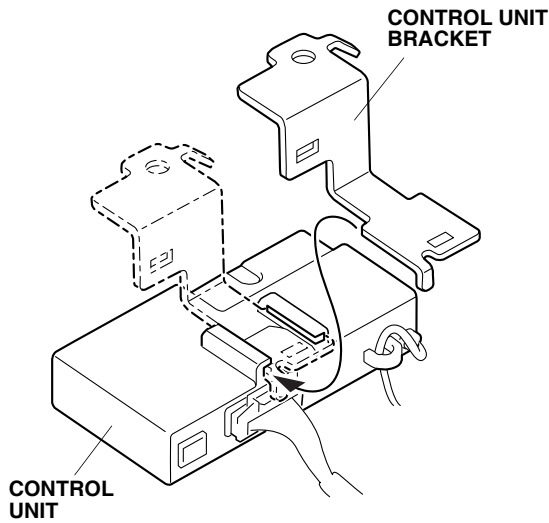

40. Attach the engine starter harness relay and fuse blocks onto the control unit bracket.

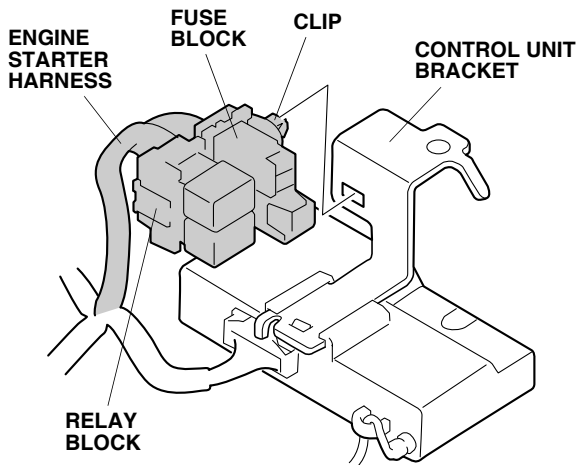

41. Remove the vehicle nut from the vehicle bracket, and secure the control unit bracket to the vehicle bracket with the vehicle nut you just removed.

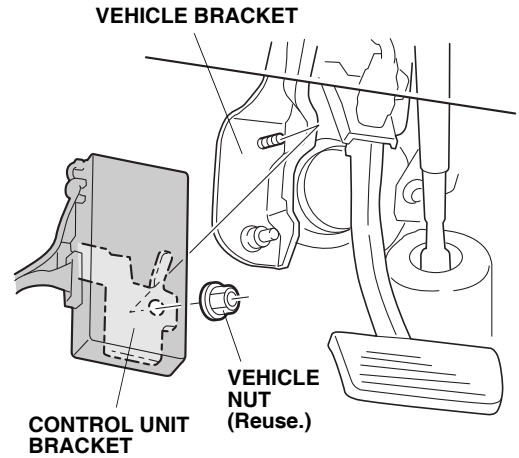

42. Route the engine starter harness along the vehicle harness, and loosely install the engine starter harness and the antenna cable to the vehicle harness with four wire ties.

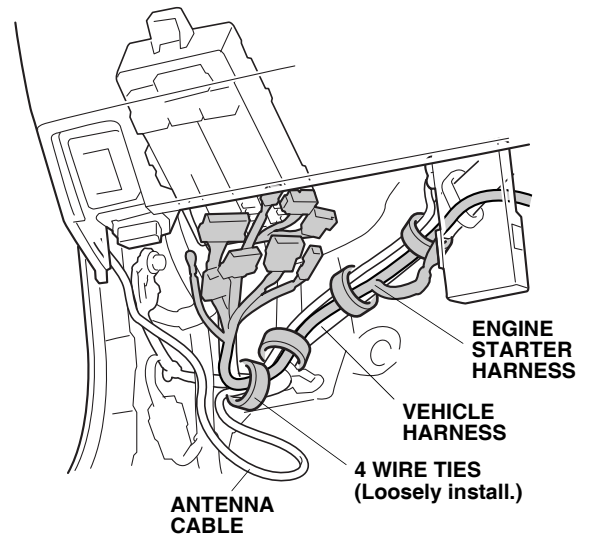

43. While wearing gloves, locate and remove the blue tape from the vehicle 2-pin connector (white) behind the fuse box. Plug the vehicle 2-pin connector (white) into the engine starter harness 2-pin connector.

NOTICE: The aluminum structure under the dashboard has sharp edges.

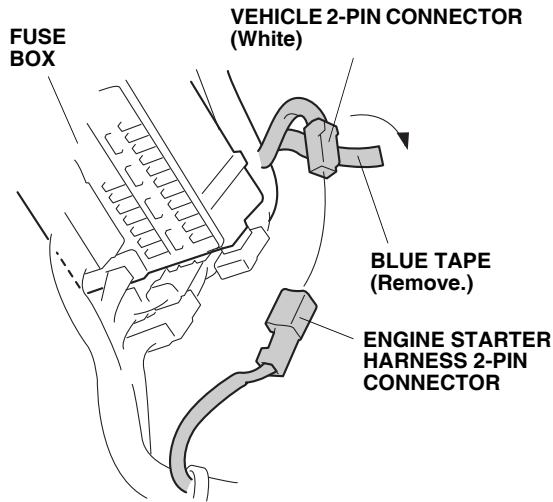

44. Unplug the vehicle 24-pin connector (white) from the bottom of the fuse box, and plug it into the engine starter harness 24-pin connector. Plug the remaining engine starter harness 24-pin connector into the fuse box 24-pin connector (white).

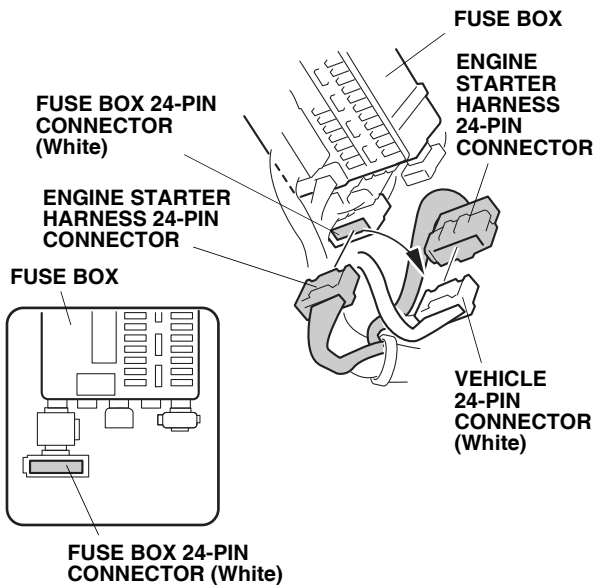

45. Attach the clip from the engine starter harness 24-pin connector to the clip holder on the bottom of the fuse box area shown.

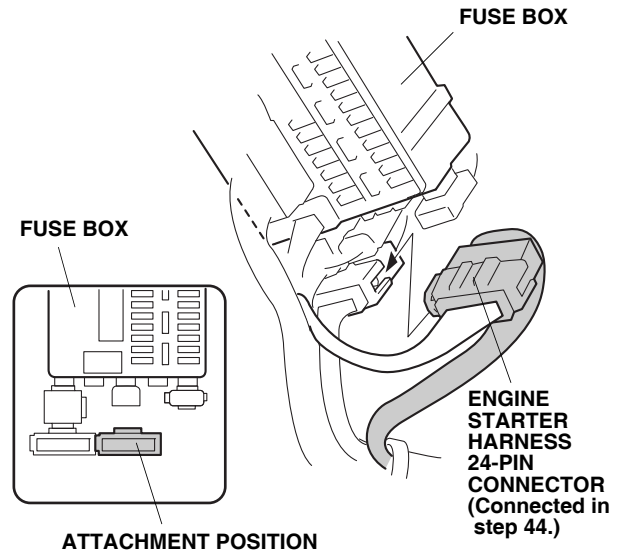

46. Unplug the vehicle 20-pin connector (green) from the fuse box, and plug it into the engine starter harness 20-pin connector. Plug the remaining engine starter harness 20-pin connector into the fuse box 20-pin connector.

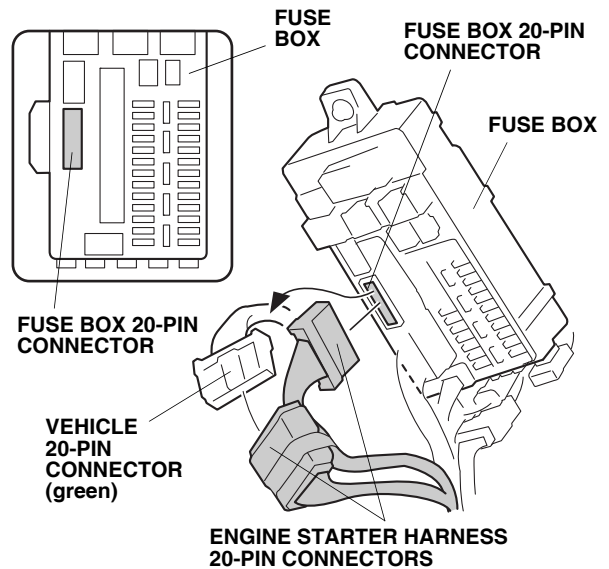

47. Unplug the vehicle 5-pin connector from the fuse box, and plug it into the engine starter harness 5-pin connector. Plug the remaining engine starter harness 5-pin connector into the fuse box 5-pin connector.

NOTE: Check that the 5-pin connectors are plugged in properly and locked. A loose connector can cause the engine to stall during driving.

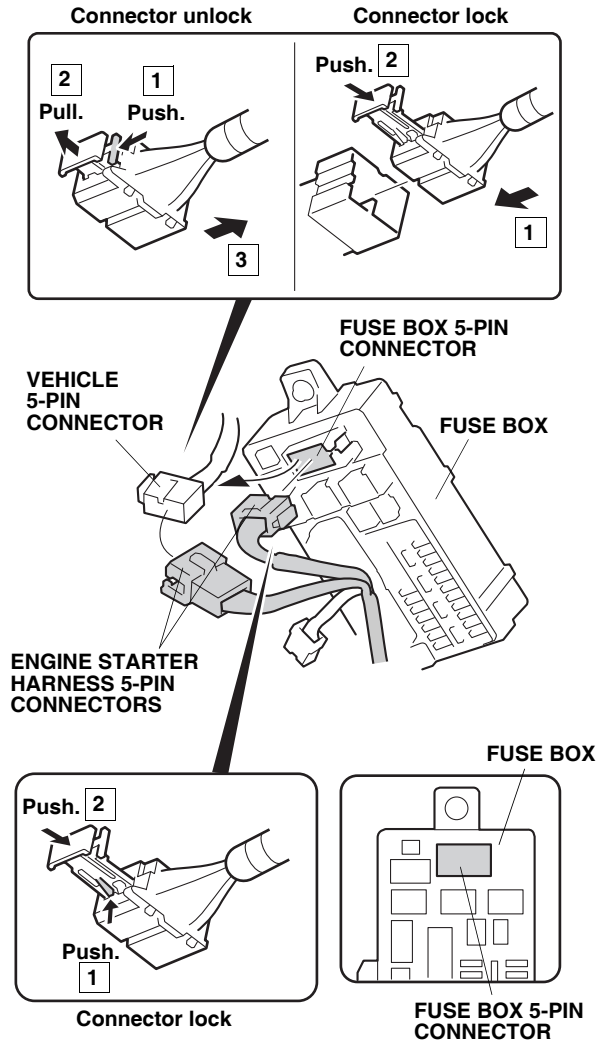

48. Plug the engine starter harness 12-pin connector into the fuse box 12-pin connector.

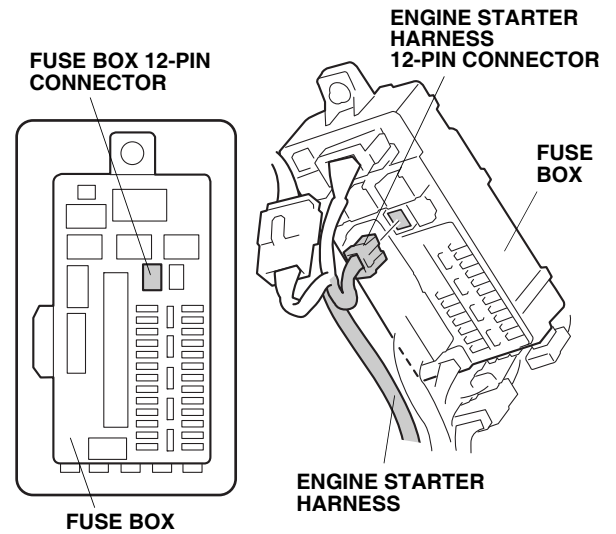

49. Wrap one urethane tape around the engine starter harness 5-pin connector and the vehicle 5-pin connector as shown.

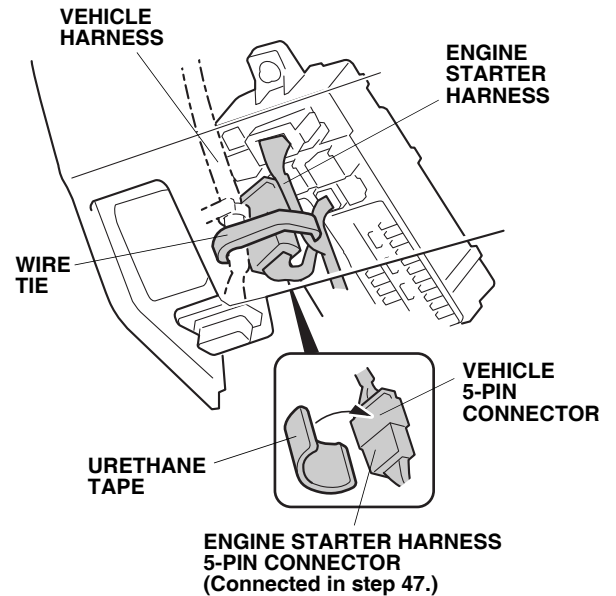

50. Secure the engine starter harness 5-pin connector and the engine starter harness to the vehicle harness with one wire tie.

51. Remove the vehicle ground bolt. Attach the engine starter harness ground terminal to the vehicle ground terminal, and reinstall the vehicle ground bolt.

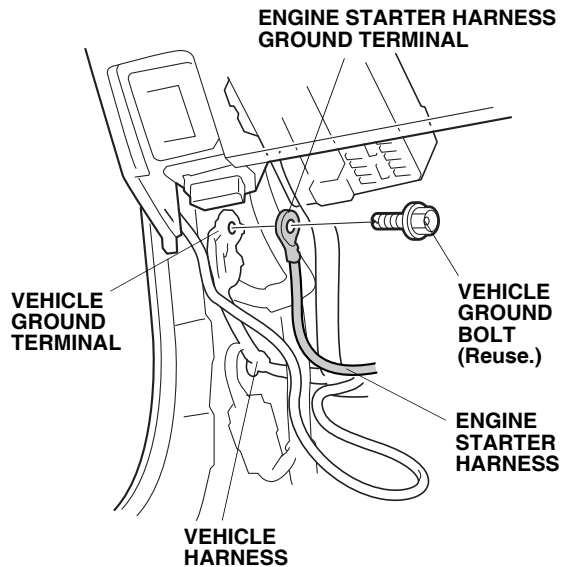

52. Secure the antenna cable and engine starter harness to the vehicle harness with four wire ties installed in step 42.

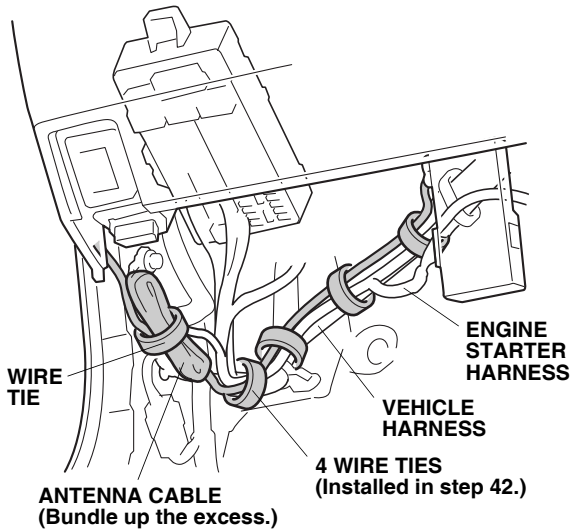

53. Bundle up the excess antenna cable as shown, and secure it to the vehicle harness with one wire tie.

54. To gain access to route of the engine starter harness, remove the vehicle bolt from the vehicle bracket, and remove the vehicle unit.

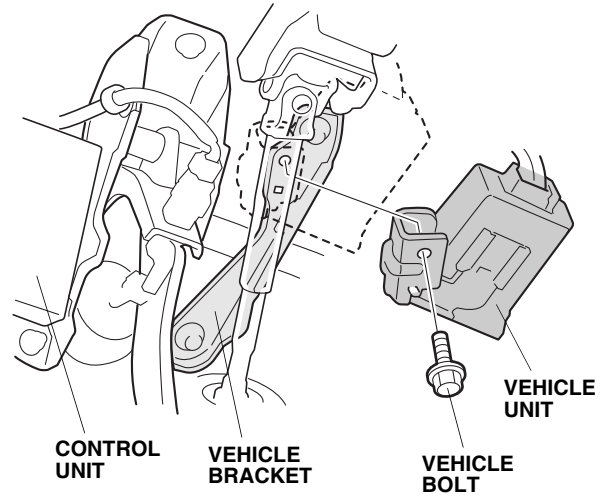

55. Attach the engine starter harness clip to the vehicle bracket.

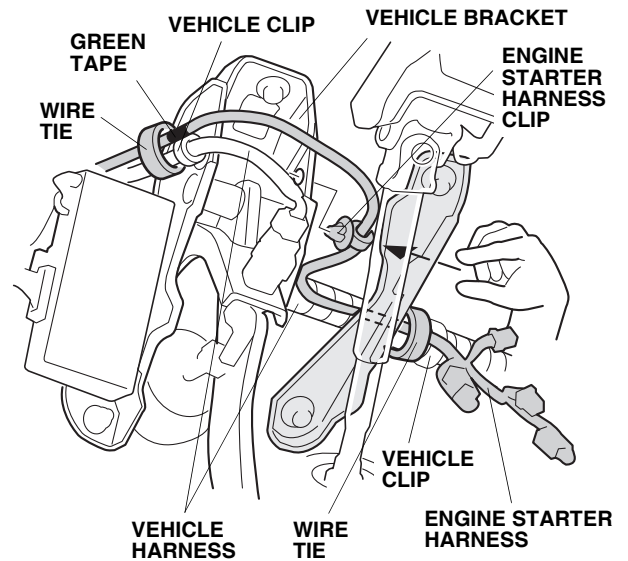

56. Align the green tape on the engine starter harness with vehicle clip, and secure the engine starter harness to the vehicle harness with two wire ties.

57. Reinstall the vehicle unit.

58. Route the two 12-pin connectors and two 8-pin connectors of the engine starter harness along the vehicle harness as shown.

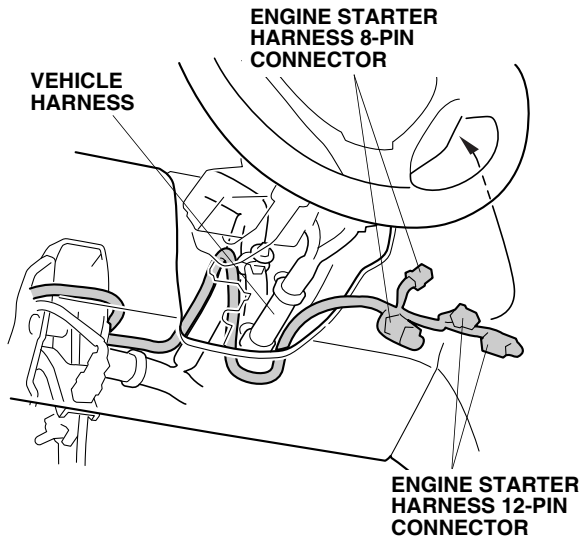

59. Route the two 12-pin connectors and two 8-pin connectors of the engine starter harness along the vehicle harness as shown.

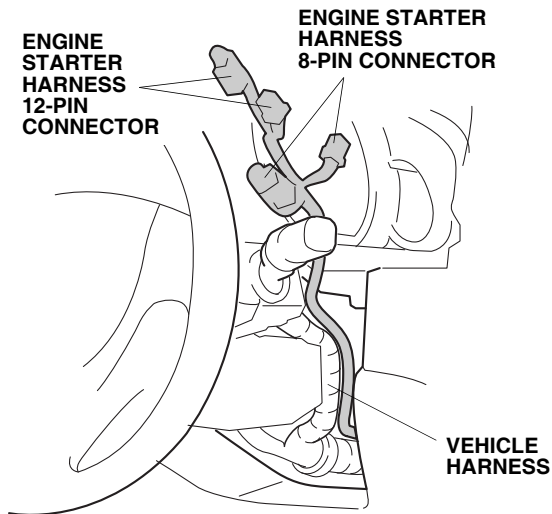

60. Unplug the vehicle 12-pin connector from the turn signal switch, and plug it into the engine starter harness 12-pin connector. Plug the remaining engine starter harness 12-pin connector into the turn signal switch.

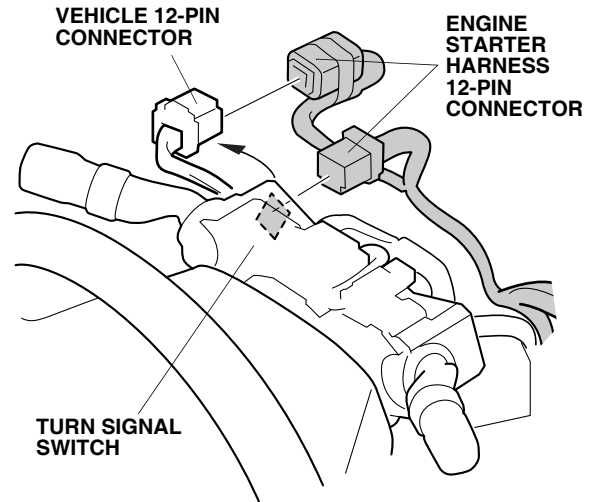

61. Unplug the vehicle 8-pin connector from the wiper switch, and plug it into the engine starter harness 8-pin connector. Plug the remaining engine starter harness 8-pin connector into the wiper switch.

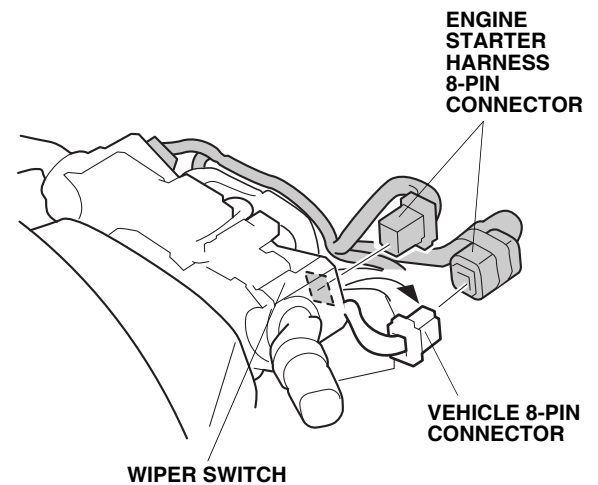

62. Secure the engine starter harness to the vehicle harness with four wire ties. Do not secure it to the SRS harness.

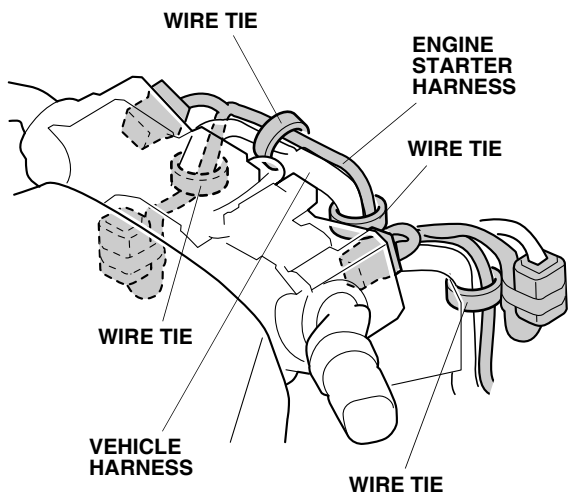

63. Secure the engine starter harness to the vehicle harness with one wire tie.

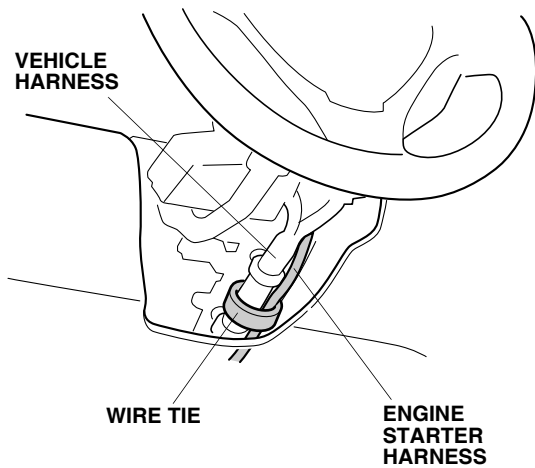

64. Secure the engine starter harness to the vehicle harness with two wire ties as shown.

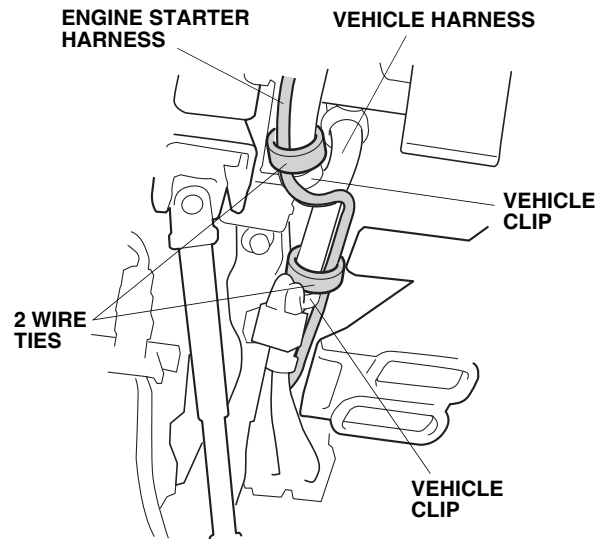

65. Under the hood, locate the area where the caution label will attach. Using isopropyl alcohol on a shop towel, clean the area where the caution label will attach.

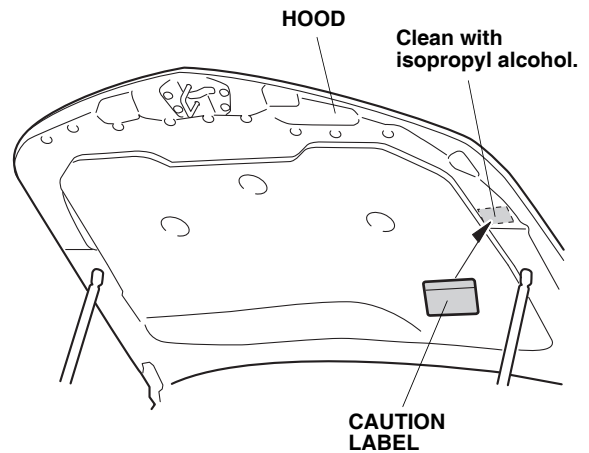

66. Attach the caution label to the hood in the area shown.

67. Check that all wire harnesses and cables are routed properly and that all connectors are plugged in.
68. Reinstall all removed parts. Take care not to pinch the side curtain airbag with the clip during reinstallation of the left front A-pillar trim. Do not push the front pillar trim excessively.
69. Reconnect the negative cable to the battery.
70. Check the operation of the headlights and windshield wipers.
71. Enter the anti-theft codes for the audio system and the navigation system (if equipped).
72. Reset the clock on vehicles without navigation.
73. Do the **REMOTE ENGINE STARTER REGISTRATION** (Page 17) and **FUNCTION CHECK** (Page 20).

REMOTE ENGINE STARTER REGISTRATION

1. Acquire a PCM Code from ISIS.

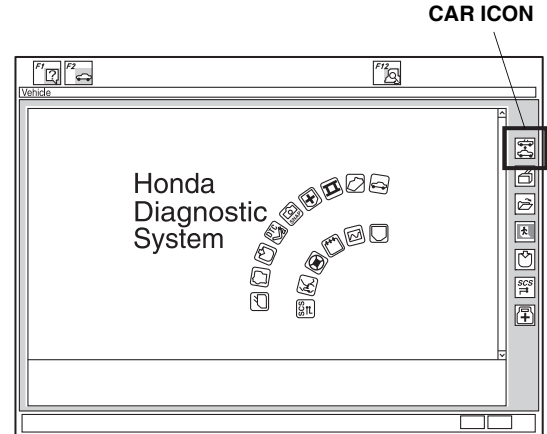

2. Connect the HDS tester to the OBD II data link connector, then turn the ignition switch on.
3. Start the HDS, and click the car icon.
4. Input the VIN and other requirements in accordance with the HDS, then click the check button.

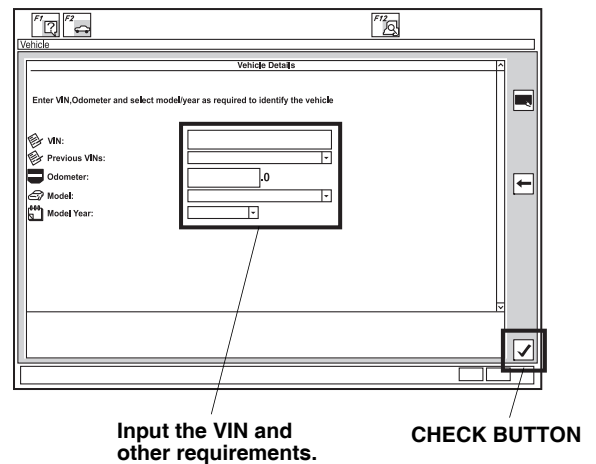

- Select the "Honda Systems", then click the check button.

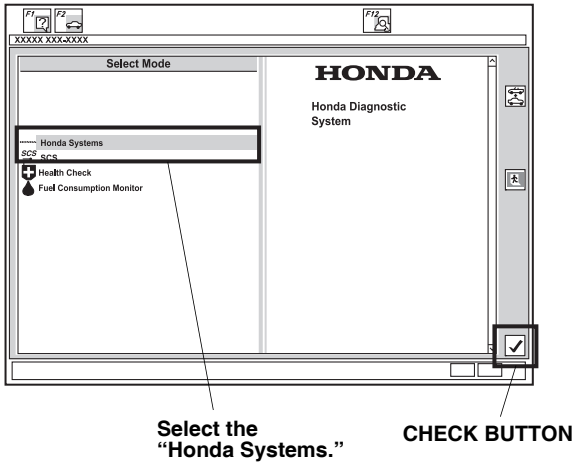

- Check that "REMARKS" is shown, then click the check button.

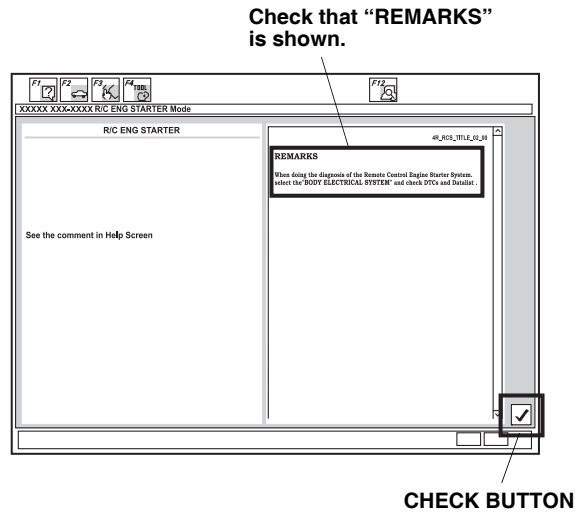

- Select the "R/C ENG STARTER" and click the check button.

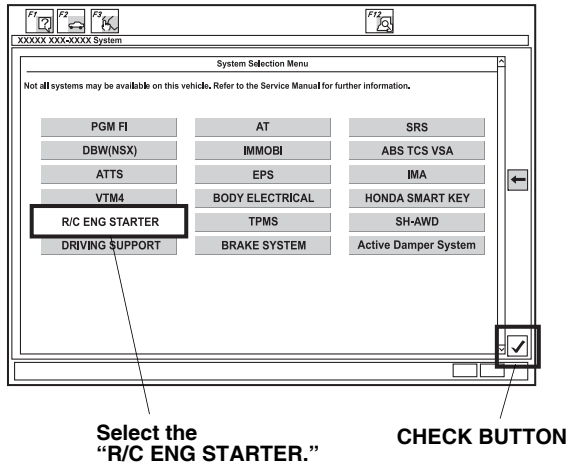

- Select the "REGISTER REMOTE CONTROL ENGINE STARTER UNIT", then click the check button.

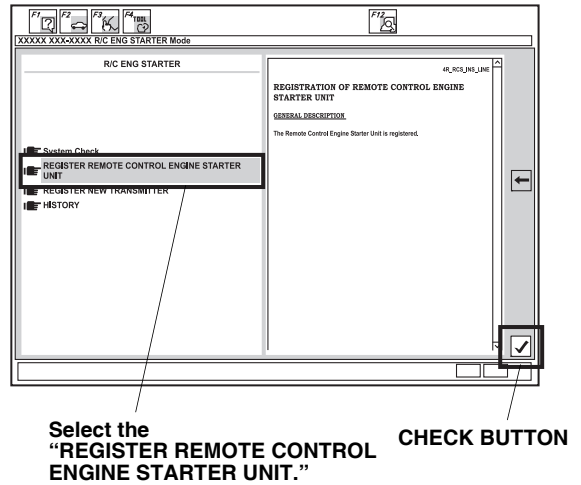

- Check that "Obtain PCM-code (IMMOBILIZER PCM CODE) from iN. This vehicle's VIN will be required to obtain the password. (USA)" is shown, then click the check button.

Check that "Obtain PCM-code (IMMOBILIZER PCM CODE) from iN. This vehicle's VIN will be required to obtain the password. (USA)" is shown.

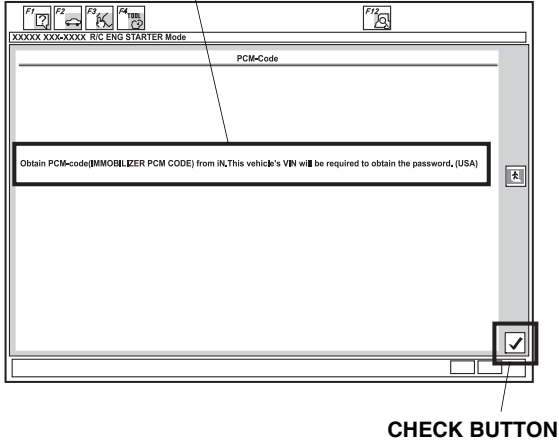

- Input the PCM Code, then click the check button.
NOTE: To ensure security, the PCM code (password) is changed every day, so it is impossible to register the remote controlled engine starter if the date of the PCM code acquisition and registration are different. The date of the HDS tester should also be the same.

Input the PCM Code.

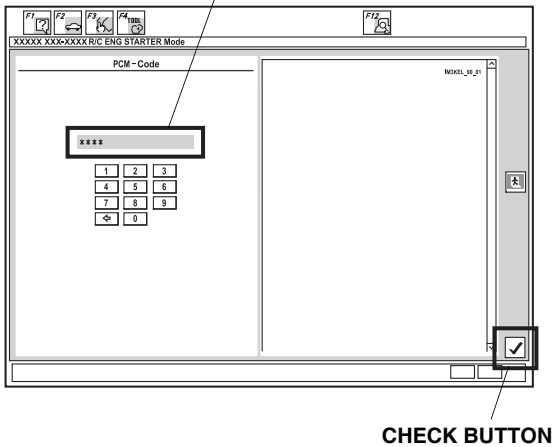

- Check that "The registration of the Remote Control Engine Starter Unit has been completed" is shown, then click the check button.

Check that "The registration of the Remote Control Engine Starter Unit has been completed" is shown.

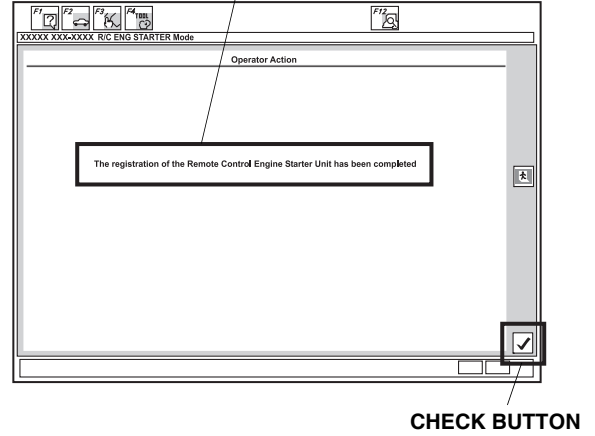

- Check that "Check that the engine can be started by the Transmitter" is shown, then click the check button.

Check that "Check that the engine can be started by the Transmitter" is shown.

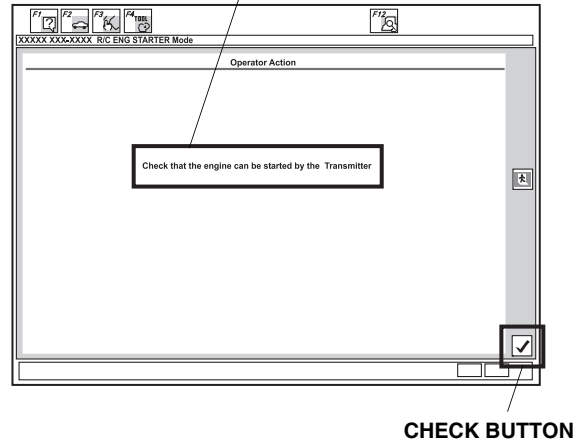

- Perform the function test on the next page, then remove the HDS.

FUNCTION CHECK

Operating Conditions

- Hood is closed
- Shift lever in park
- The key is out of the ignition switch
- All doors and trunk lid closed and locked

Inspection

1. Within 1 second, press the command button, and then the start button on the transmitter.
The engine should start if all operating conditions are met.

Does the engine start?

| |
|--|
| Yes - Operation is normal. |
| No: <ul style="list-style-type: none">• Make sure all "Operating Conditions" are met.• Check the engine starter harness connections.• Connect the HDS and check for an indicated failure. (Refer to the appropriate service manual for details.) |

2. Press the command button on the transmitter, and within 1 second, press the stop button. The engine should stop.

Does the engine stop?

| |
|--|
| Yes - Operation is normal. |
| No - Check the engine starter harness connections. |

3. After the engine has stopped, start the engine again, and check that the engine stops after each of the following conditions:

NOTE: After each test the ignition switch must be cycled, or the driver's door must be opened and closed.

- Move the shift lever out of the P position.
- Unlock or open the doors or the trunk lid.
- Open the hood.
- Insert the key in the ignition switch.
- Press the brake pedal.

Does the engine stop after each of these tests?

| |
|--|
| Yes - Operation is normal. |
| No - Check the engine starter harness connections. |

4. Check that the power window or the moonroof does not function and the shift lever does not move to any position but the P position when the engine is started with the transmitter.
5. Press the command button on the transmitter two times, and check the vehicle condition on the display.
6. Check the operation of the transmitter when the vehicle is 100 m to 150 m (325 to 490 ft.) away and in direct sight.

