

## PARTS LIST

Door visor (front left)

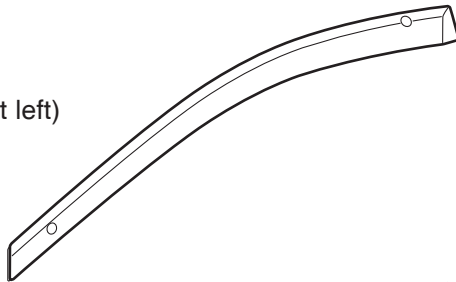

Door visor (front right)

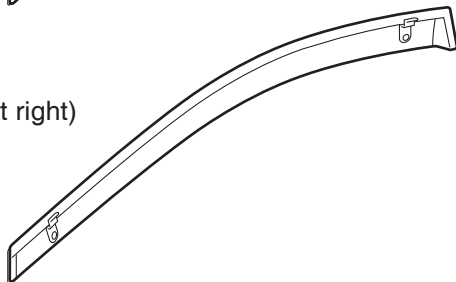

Door visor (rear left)



Door visor (rear right)



Primer

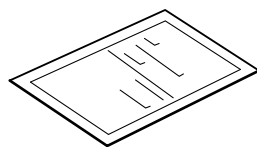

4 EPT sealers



## SUPPLIES REQUIRED

Isopropyl alcohol  
Shop towel  
Masking tape  
Scale  
Glove

## INSTALLATION

### NOTE:

- These instructions show the left door visors being installed. The same procedure applies to installing of the right door visors.
- Be careful not to damage the paint finish and the glass run channels when installing the door visors.
- Handle the door visors with care. They are not designed to absorb shock or impact.
- Do not use organic solvents such as thinner, benzene, and alcohol to clean the door visors as they may damage the plastic surfaces.
- This door visor kit should only be installed if the ambient air temperature is 60°F (15°C) or above.
- To allow the adhesive to cure, do not wash the vehicle for 24 hours.
- Read the label on the primer before using the primer.

### Installing the Front Door Visor

1. Lower the front door glass completely. Remove the door glass run channel from the door sash in the area shown. Do not remove the glass run channel from the door mirror base and the rear of the door.

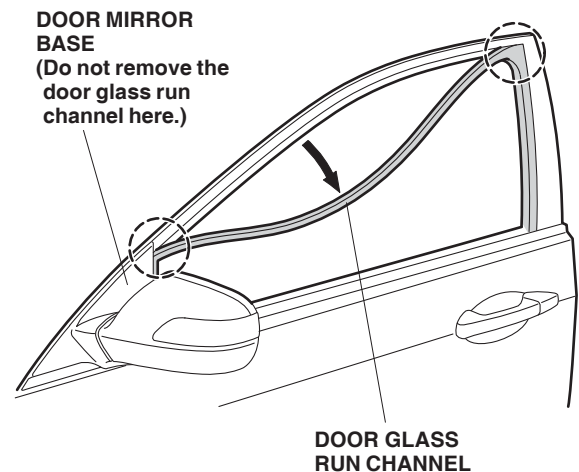

2. Push the two brackets on the door visor onto the door sash. Insert the front tab under the door mirror base.

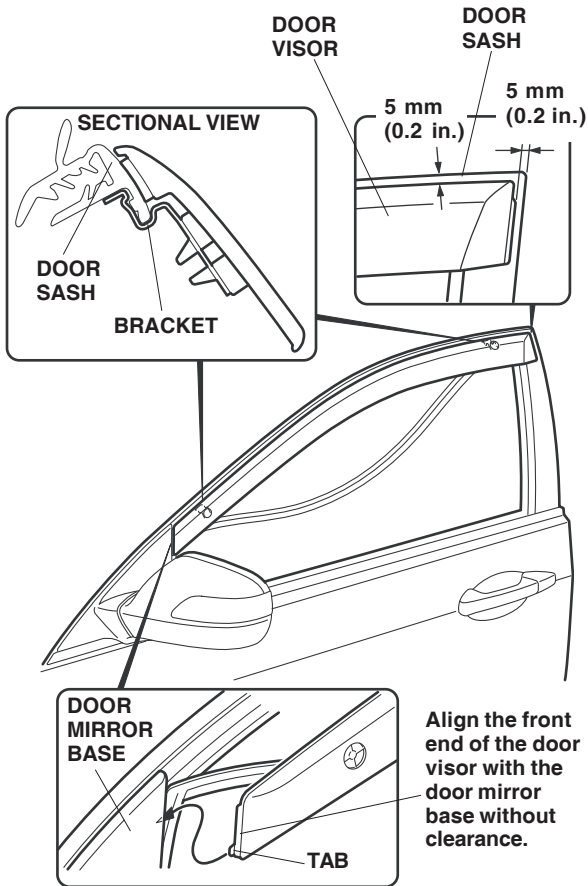

3. Align the front end of the door visor with the door mirror base so there is no clearance. Adjust the door visor so that the distance between the rear edges of the door visor and door sash is 5 mm (0.2 in.).

4. Apply masking tape to the door sash along the upper, front, and rear edges of the door visor as shown. Remove the door visor.

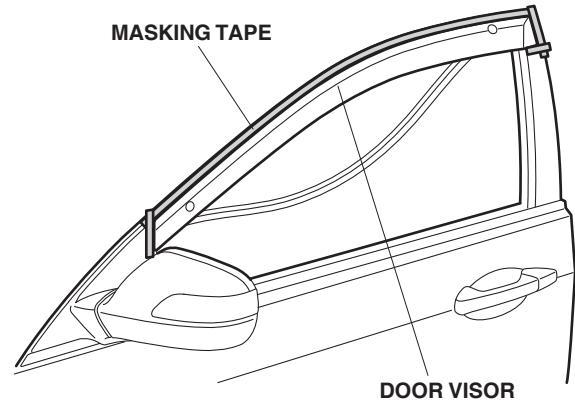

5. Using isopropyl alcohol, thoroughly clean the door sash in the area surrounded by the masking tape. Allow it to dry.
6. While wearing gloves, apply the primer to the door sash within the masking tape area. Wipe up any excess primer at once. Allow the primer to dry for at least 3 minutes, then remove the masking tape.

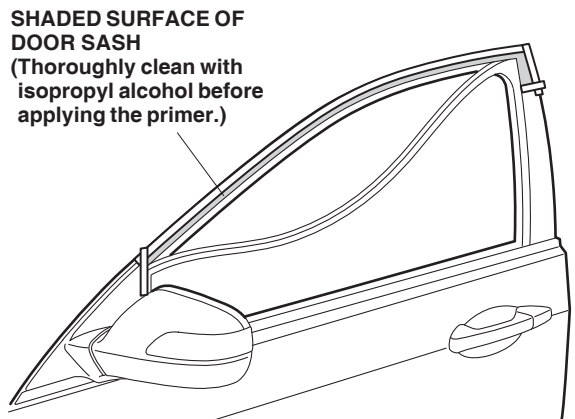

- Remove the adhesive backing from the EPT sealer. Attach the EPT sealer to the door sash, and apply pressure. Apply the EPT sealer as shown, with the upper edge in contact with the door sash.

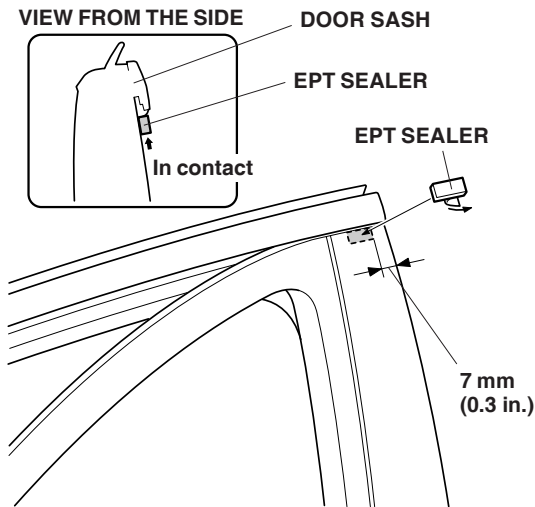

- Peel the adhesive backings from the end, fold them back, then temporarily attach them to the front of the door visor with masking tape.

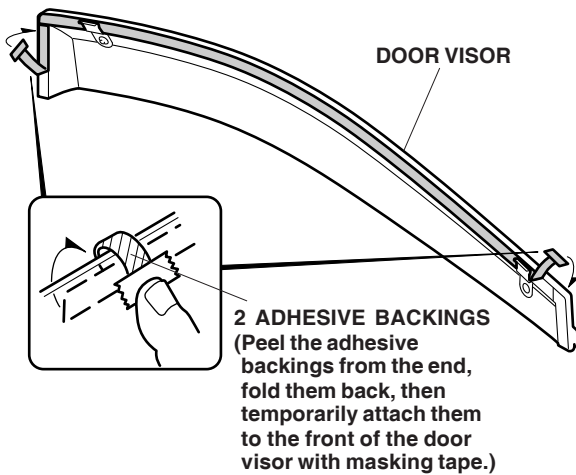

- Attach the door visor the same as in steps 2 and 3.

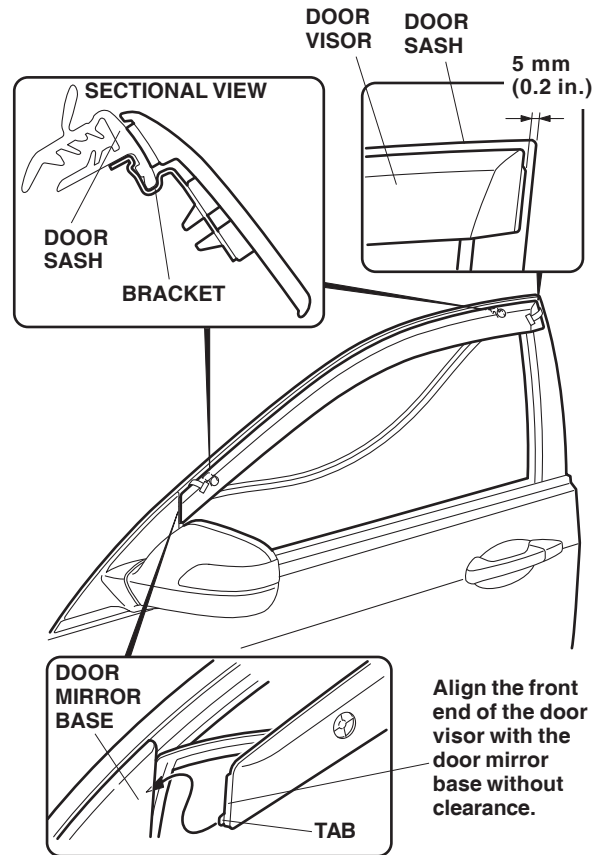

- While holding light pressure on the door visor, carefully remove the adhesive backing. Using the palm of your hand, hold the door visor firmly against the door for 30 seconds.

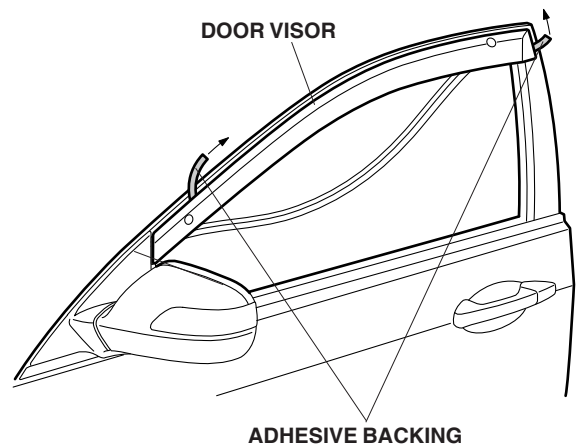

11. Reinstall the door glass run channel. Seat the door glass run channel properly.

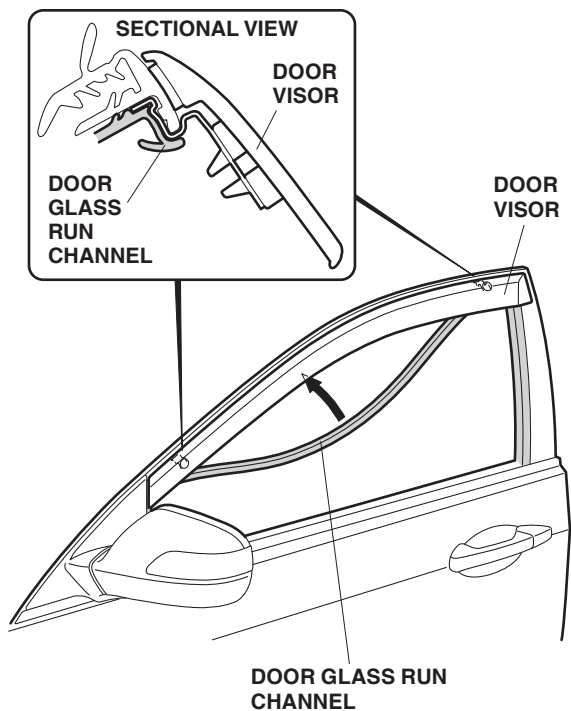

12. Check that the run channel is securely installed.

### Installing the Rear Door Visor

13. Lower the rear door glass completely. Remove the door glass run channel from the door sash in the areas shown.

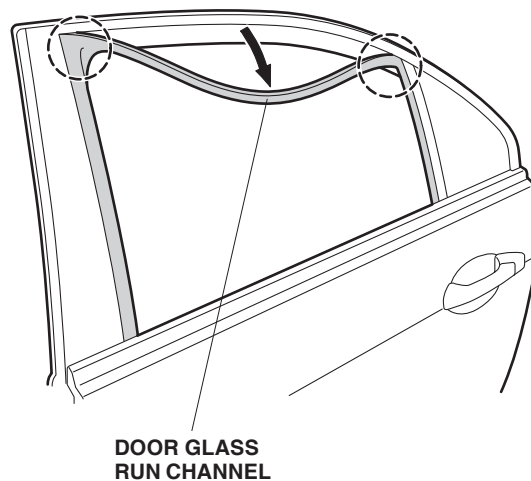

14. Push the two brackets on the door visor onto the door sash.

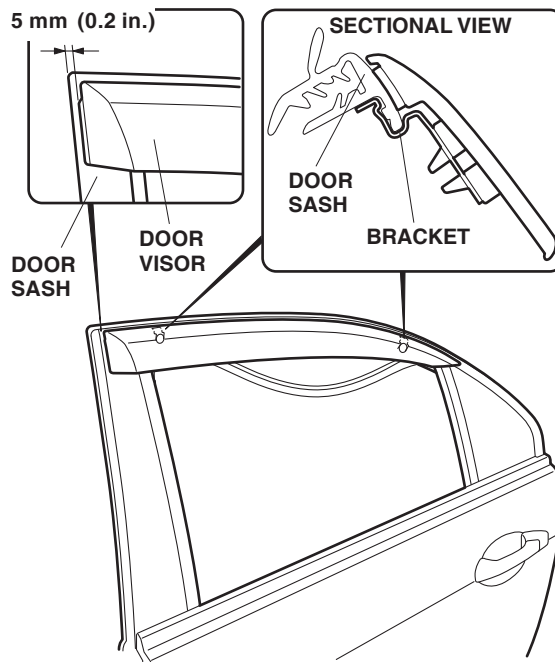

15. Adjust the door visor so that the distance between the front edges of the door visor and door sash is 5 mm (0.2 in.).

- Apply masking tape to the door sash along the upper, front and rear edges of the door visor as shown. Remove the door visor.

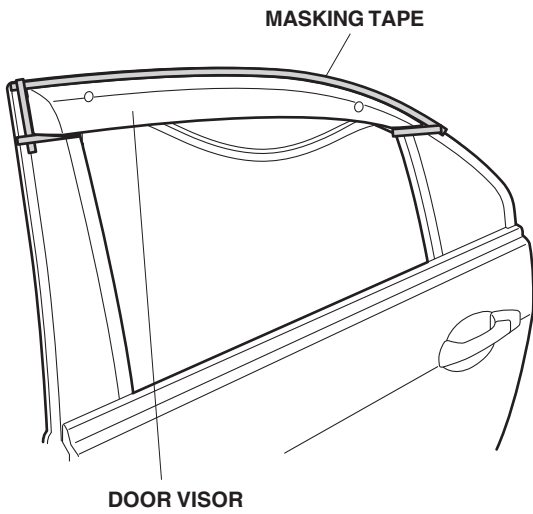

- Using isopropyl alcohol, thoroughly clean the door sash in the area surrounded by the masking tape. Allow it to dry.
- While wearing gloves, apply the primer to the door sash within the masking tape area. Wipe up any excess primer at once. Allow the primer to dry for at least 3 minutes, then remove the masking tape.



- Remove the adhesive backing from the EPT sealer. Attach the EPT sealer to the door sash, and apply pressure. Apply the EPT sealer as shown, with the upper edge in contact with the door sash.

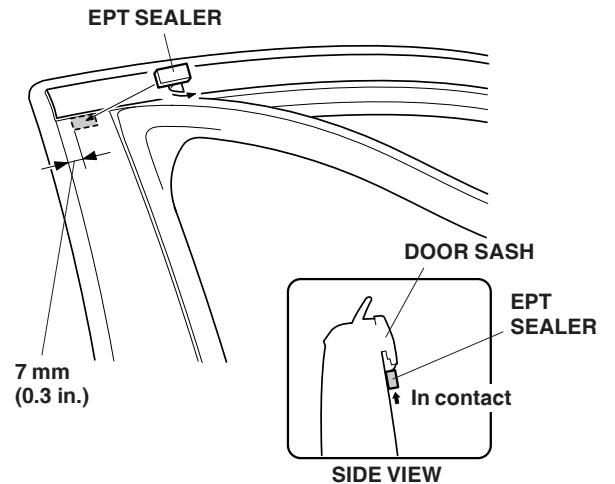

- Peel the adhesive backings from the end, fold them back, then temporarily attach them to the front of the door visor with masking tape.

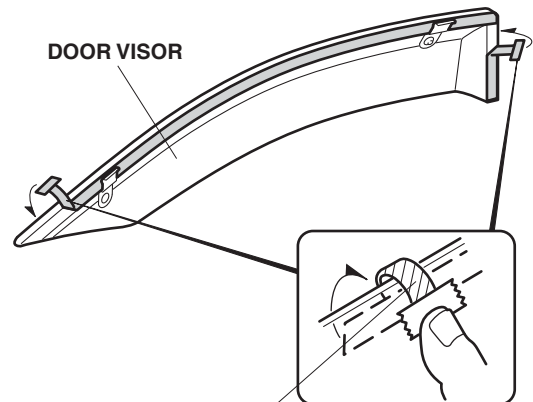

- 2 ADHESIVE BACKINGS**  
(Peel the adhesive backings from the end, fold them back, then temporarily attach them to the front of the door visor with masking tape.)

21. Attach the door visor the same as in steps 14 and 15.

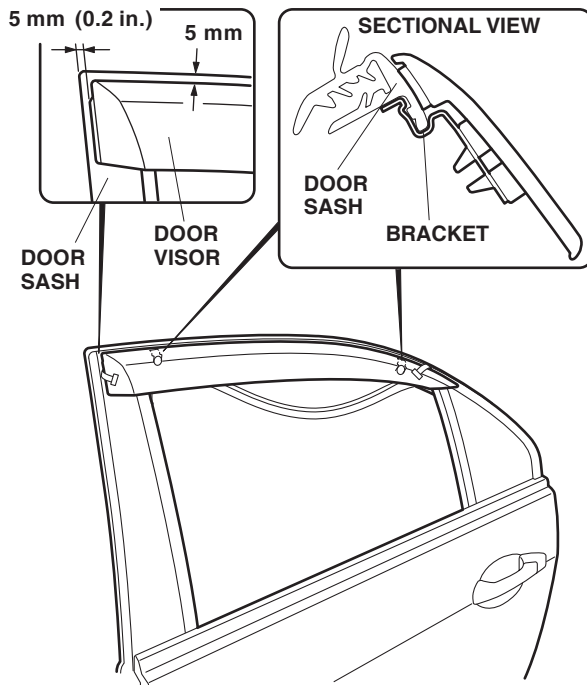

22. While holding light pressure on the door visor, carefully remove the adhesive backing. Using the palm of your hand, hold the door visor firmly against the door for 30 seconds.

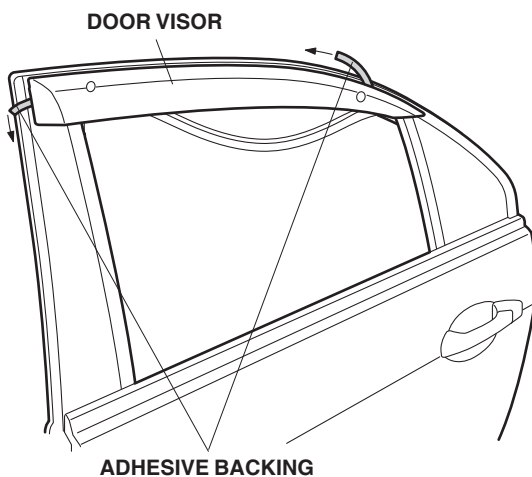

23. Reinstall the door glass run channel. Seat the glass run channel properly.

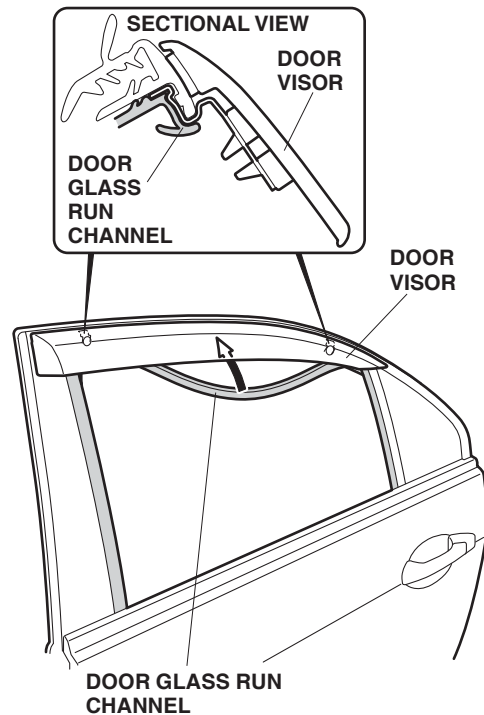

24. Check that the run channel is securely installed.  
 25. Repeat steps 1 through 24 to install the door visors on the right side of the vehicle.  
 26. Raise and lower all the windows several times to seat the glass run channels.

**NOTE:** Whenever the battery is disconnected, the driver's window AUTO function is disabled.

27. Start the engine. Push down on the driver's window switch until the window is fully open.

28. Pull up on the driver's window switch to close the window completely, then hold the switch for 2 seconds or more.
29. Lower and raise the driver's window to check the operation of the driver's window AUTO function.
30. Do the PCM idle learn procedure.
  - Make sure all electrical items are turned off.
  - Start the engine. Hold the engine speed at 3,000 rpm with no load (in Park or Neutral) until the radiator fan comes on.
  - Let the engine idle for about 10 minutes with the throttle fully closed and with all electrical items off.

#### **USE AND CARE**

- To clean the door visor, wipe it with a soft cloth dampened with clean water.
- To remove dust and dirt, clean with a solution of liquid dishwashing soap and water using a soft cloth or chamois. Never use organic solvents such as thinner, benzine, alcohol, etc., or cleaners containing compounds.