



ACURA

INSTALLATION INSTRUCTIONS

Accessory

STEERING WHEEL TRIM
P/N 08213-STK-200

Application

2010 RDX

Publications No.

BII 41806

Issue Date

JUNE 2009

PARTS LIST

Steering wheel trim

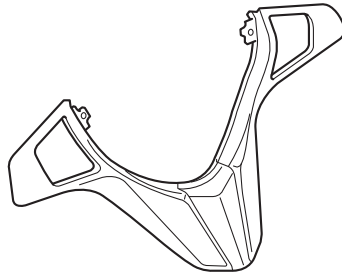

2 TORX bolts



TOOLS REQUIRED

- Phillips screwdriver
- Flat-tip screwdriver
- 14 mm T-handle wrench
- Torque wrench
- Steering wheel puller
- T30 TORX bit

INSTALLATION

Client Information: The information in this installation instruction is intended for use only by skilled technicians who have the proper tools, equipment, and training to correctly and safely add equipment to your vehicle. These procedures should not be attempted by "do-it-yourselfers."

NOTE:

Observe all safety notes and precautions described in the service manual in addition to these described in this installation instruction.

1. Make sure you have the anti-theft codes for the radio and navigation system (if equipped), then write down the radio presets.
2. Disconnect the negative cable from the battery, and wait for at least 3 minutes before you start to install the steering wheel trim.
3. From under the driver's side airbag, pry on the six retaining tabs and remove the access panel.
4. Remove the horn ground terminal and the airbag connectors from the holder on the wire guide. Unplug the horn ground terminals.

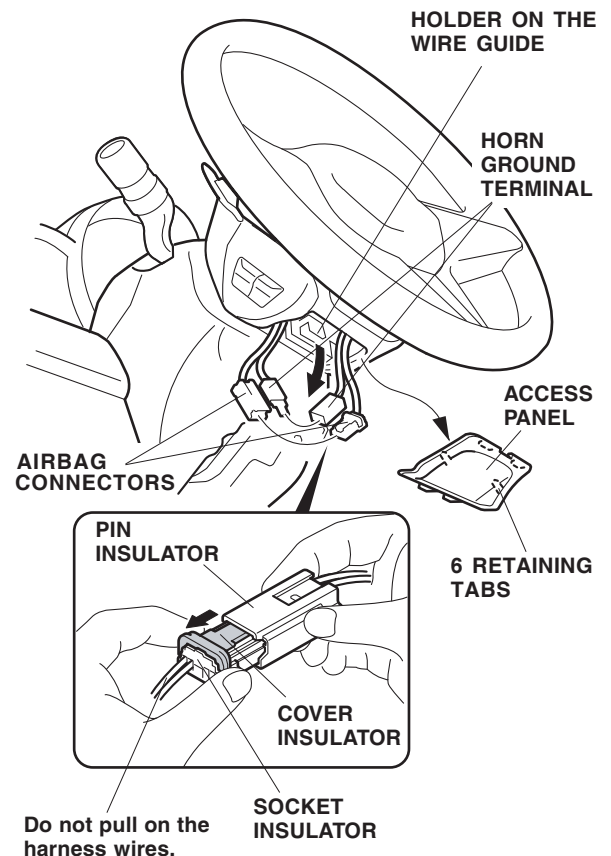

5. Unplug the airbag connectors. While holding the pin insulator, pull out on the cover insulator. Do not pull on the socket insulator and harness wires.

6. Remove and discard the two TORX bolts that secure the airbag, and remove the airbag. Carefully set the airbag in a secure location with the cover facing up. Do not drop or bump the airbag against anything.

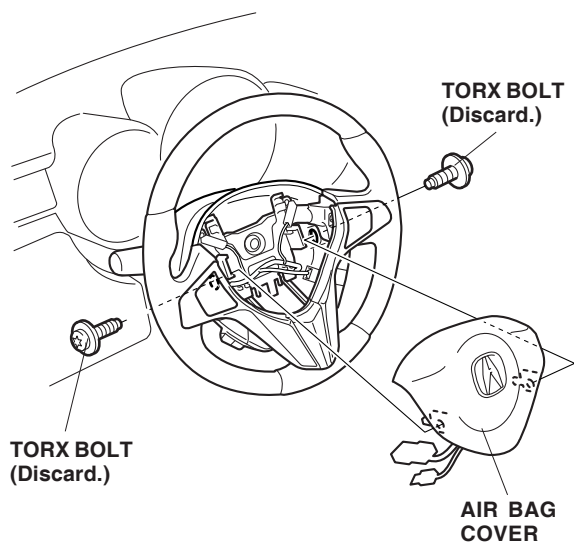

7. Turn the steering wheel so the front wheels are in the straight-ahead position.

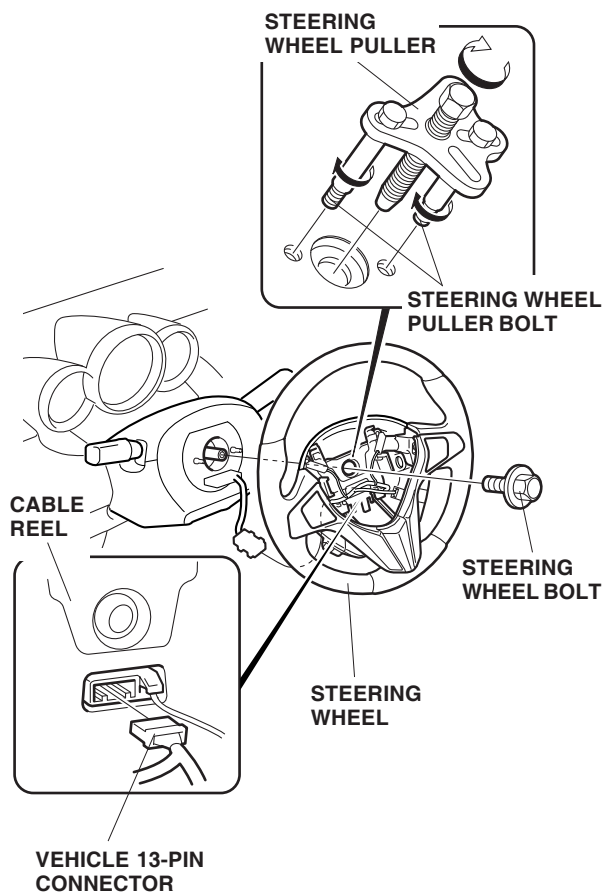

8. Remove the steering wheel bolt. Disconnect the vehicle 13-pin connector from the cable reel. Using a steering wheel puller, remove the steering wheel. Do not thread the steering wheel puller bolts in more than 10 mm. Be careful not to turn the steering wheel during removal.

- Remove the four self-tapping screws that fasten the body cover to the steering wheel, and remove the body cover.

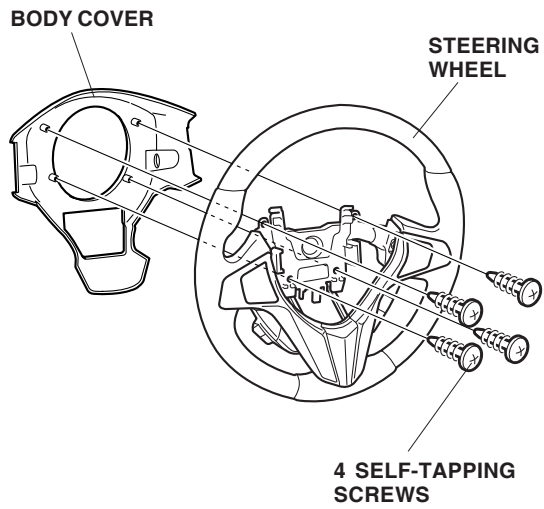

- Remove the four self-tapping screws that fasten the paddle shifters to the steering wheel.

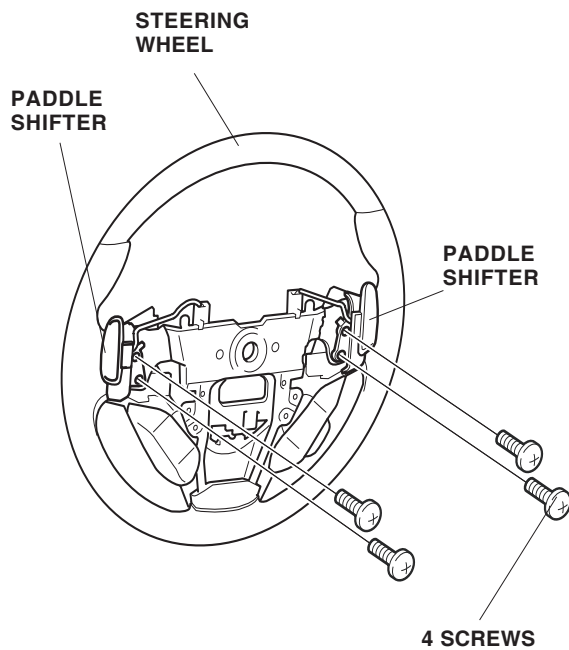

- Remove the steering trim and unplug the two switch connectors.

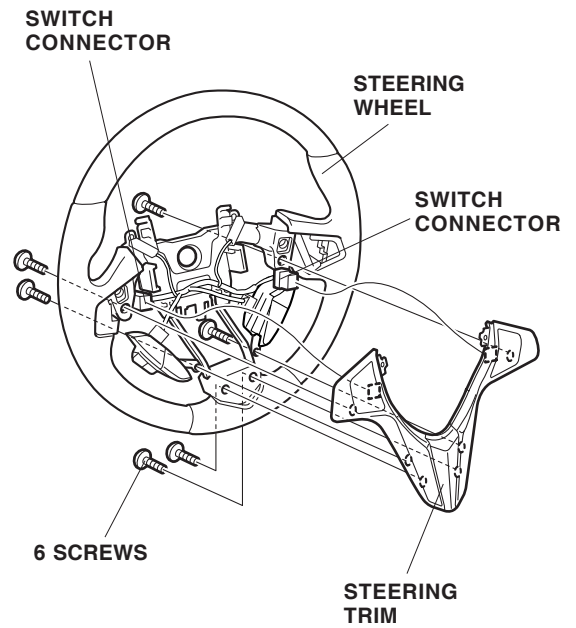

- Remove the switches from the steering trim (two screws for each switch).

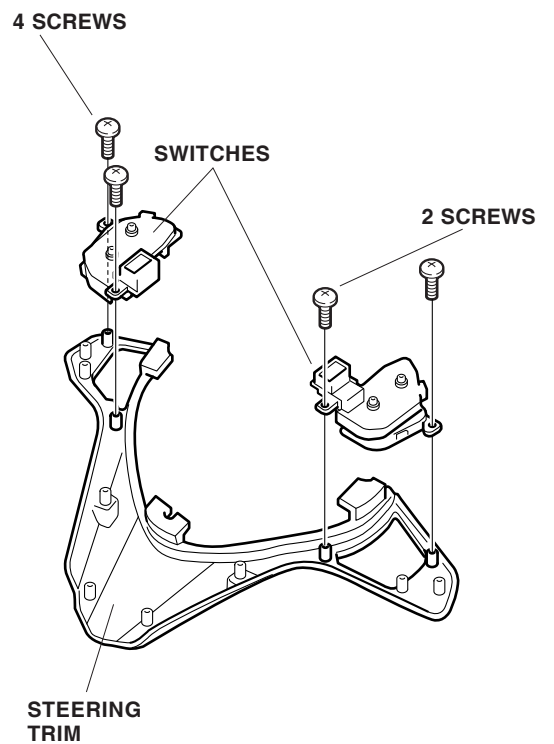

13. Install the two switches to the new steering trim with the four screws you removed.

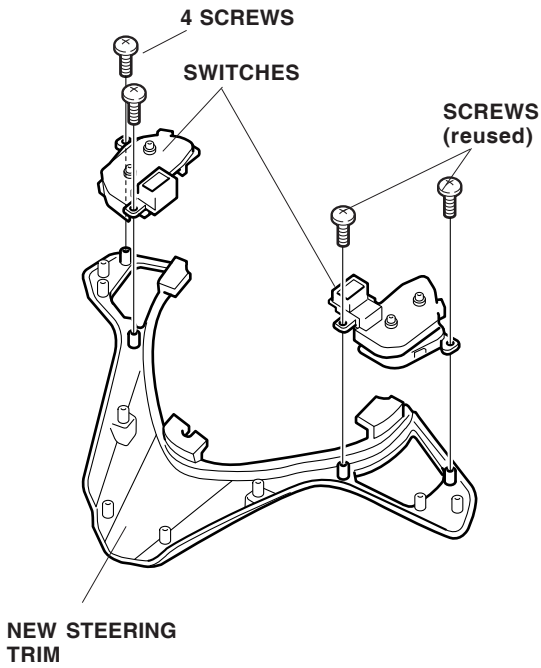

14. Install the new steering trim to the steering wheel with the six screws and connect the two switch connectors.

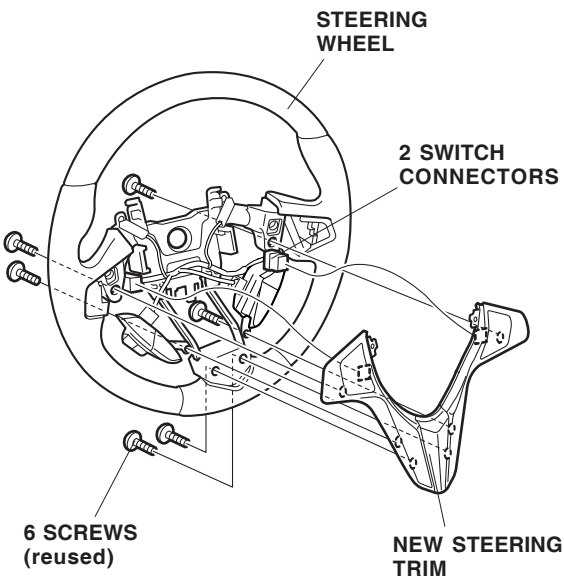

15. Install the paddle shifters to the steering wheel with the two screws you removed.

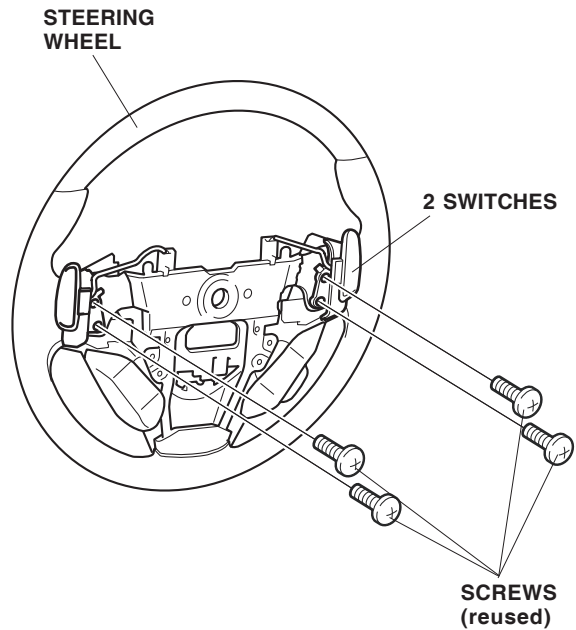

17. Install the body cover to the steering wheel with the four self-tapping screws you removed.

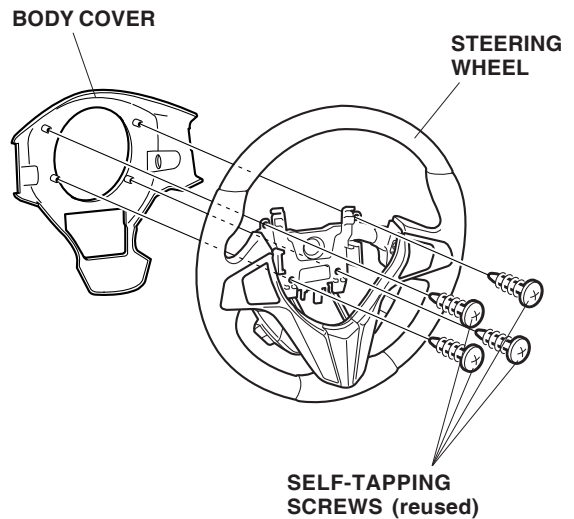

NOTE: If the cable reel was not moved, go to step 18; if it was moved, go to step 17.

17. Align the cable reel:

- Rotate the cable reel clockwise all the way until it stops.
- Turn the cable reel counterclockwise about three complete turns until the "TOP" arrow on the cable reel points up.

18. Install the steering wheel on the steering column shaft in the straight ahead position:

- Route the wire harness through the opening in the steering wheel.
- Align the two tabs of the canceling sleeve with the two cutouts in the steering wheel as shown.
- Check that the wire harnesses are not pinched.

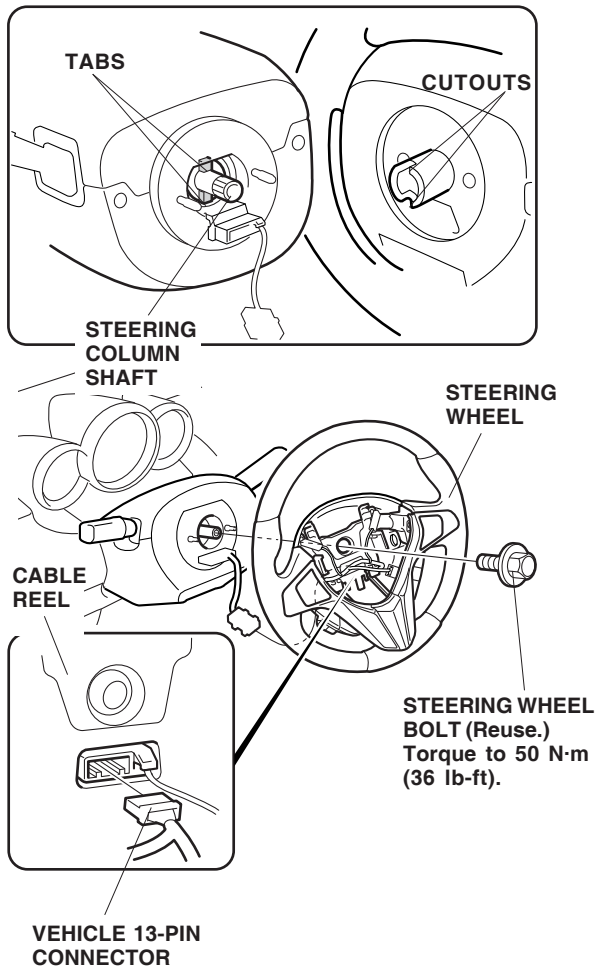

19. Install the steering wheel bolt. Torque the steering wheel nut to 49 N·m (36 lb-ft).

20. Reconnect the 13-pin connector.

21. Get the airbag, and route the airbag harness and horn harness down through the steering wheel. Position the airbag on the steering wheel, and install the two new TORX bolts. Torque the TORX bolts to 10 N·m (7.2 lb-ft).

NOTE: Make sure that the wire harnesses are not pinched.

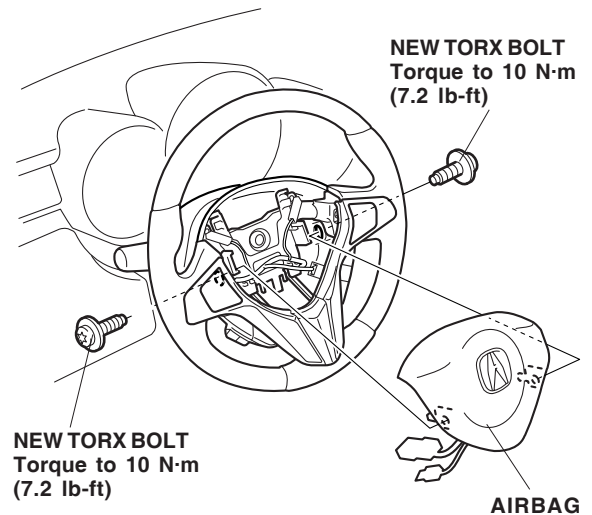

22. From under the steering wheel, connect the horn ground terminals, and attach the terminals to the holder on the wire guide.

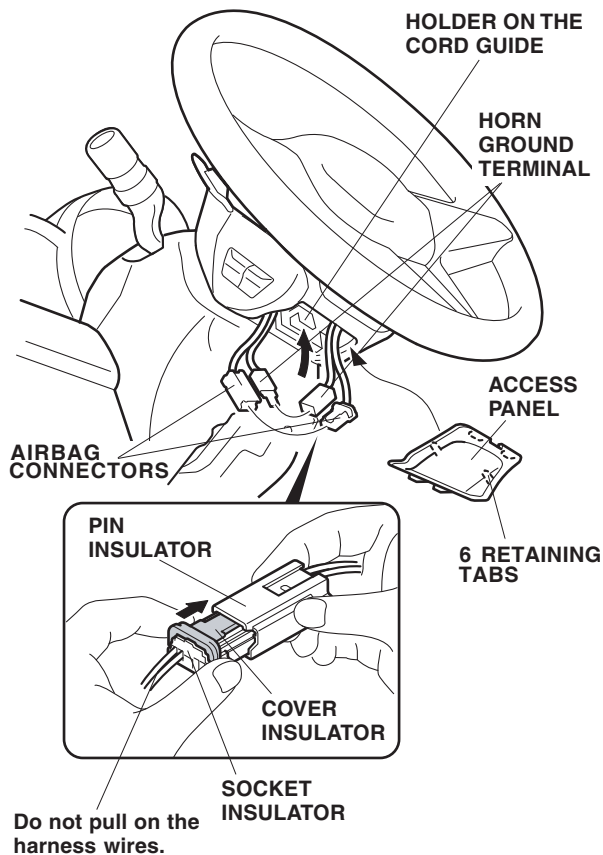

23. Connect the airbag harness connectors:

- Push the socket insulator onto the pin insulator until it contacts the tab on the pin insulator.
- Do not push the socket insulator onto the pin insulator by pushing on the cover insulator.
- Continue pushing on the socket insulator in the same direction until the cover insulator rides over the tab on the pin insulator and is locked securely.
- Reattach the airbag harness connectors to the holder on the wire guide.
- Reinstall the access panel.

24. Reconnect the negative cable to the battery.
25. Verify that the horn works.
26. Turn the ignition key ON (II), and verify that the SRS warning light comes on and stays on for 6 seconds; turn the key off to make sure the SRS warning light goes off.
27. Enter the anti-theft codes for the radio and navigation system (if equipped), then enter the client's radio presets.
28. Reset the clock.

NOTE: When the battery is disconnected, the driver's window AUTO function is disabled.

- Start the engine. Push down on the driver's window switch until the window is fully open.
- Pull up on the driver's window switch to close the window completely, then hold the switch for 1 second or more.
- Lower and raise the driver's window to check operation of the driver's window AUTO function.