



ACURA INSTALLATION INSTRUCTIONS

Accessory

MOONROOF VISOR
P/N 08R01-STX-200

Application

2010 MDX

Publications No.

BII 42091

Issue Date

NOV 2009

Put this information in the glove box with the vehicle owner's manual.

PARTS LIST

Moonroof visor

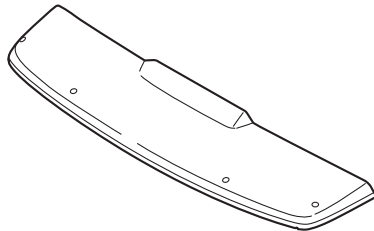

2 Brackets A

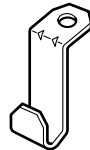

2 Brackets B



4 Nuts



4 Pieces of protective tape

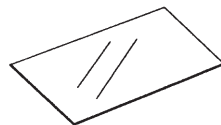

4 Screws



TOOLS AND SUPPLIES REQUIRED

10 mm Combination wrench

Felt-tip pen

#2 Phillips screwdriver

Masking tape

Isopropyl alcohol

Shop towels

Torque wrench

Ruler

INSTALLATION

1. Clean and wax the area to be covered. Use a high-quality paste wax.
2. Open the moonroof.
3. Roll up two shop towels and insert them between the roof panel and air deflector to lower the air deflector. Take care not to damage the air deflector.

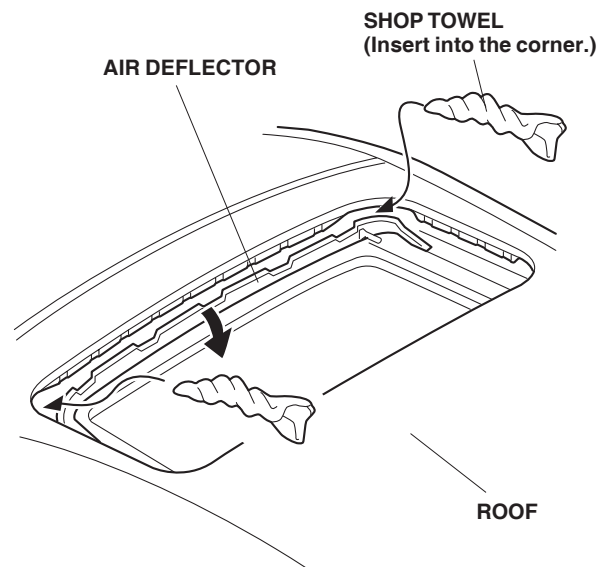

- At the left front corner of the moonroof opening, locate the front moonroof guide rail screw. From the guide rail screw, place a ruler directly outboard from the screw, and mark the edge of the roof with a felt-tip pen.

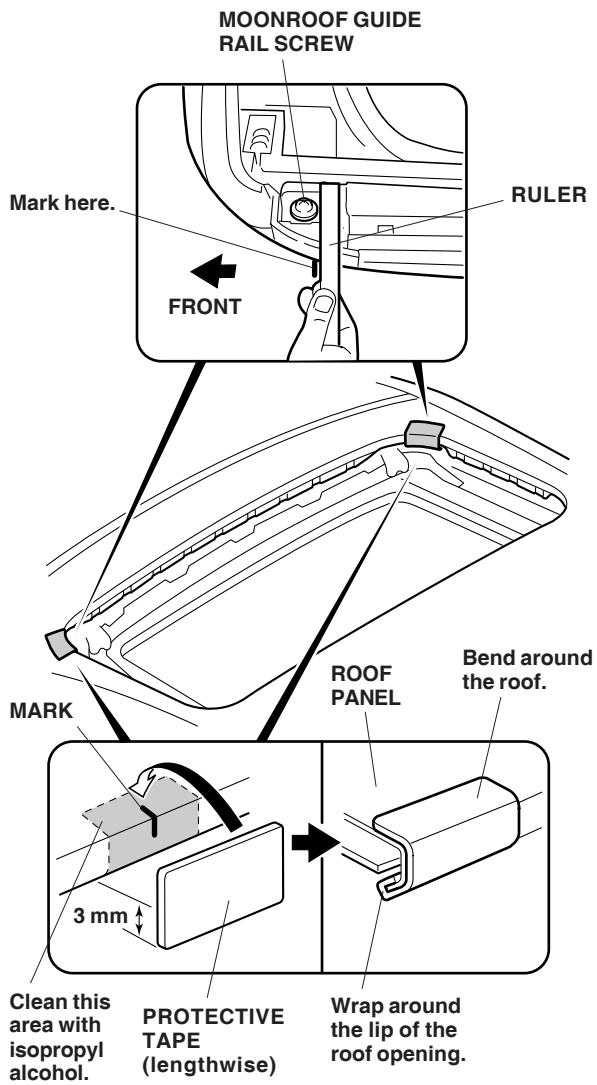

- Using isopropyl alcohol on a shop towel, clean the roof area and the inside edge of the moonroof opening, but don't wipe off the mark.
- Remove the adhesive backing from one protective tape. Starting at the bottom edge, wrap 3 mm of protective tape around the lip of the moonroof opening just in center of the mark; continue upward with the tape around the top of the roof panel.
- Repeat steps 4 thru 6 to install the protective tape on the right side of the moonroof opening.

- Using isopropyl alcohol on a shop towel, clean the second concave location from each corner of the moonroof opening. Install one protective tape at each location.

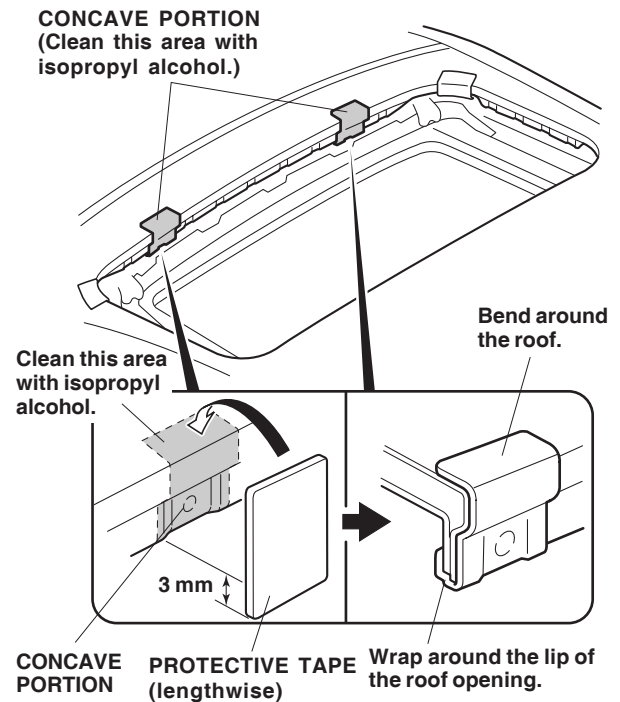

- Place the two brackets A and two brackets B into position over the protective tape and around the lip of the roof opening, and tape them into position with a piece of masking tape.

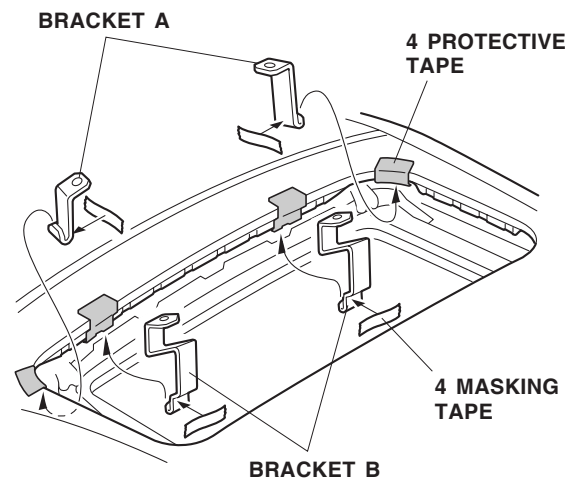

- Set the moonroof visor on the vehicle roof in front of the moonroof opening, and adjust its position so the holes in the visor are aligned with the bracket A holes. Install two screws and two nuts loosely onto the brackets A.

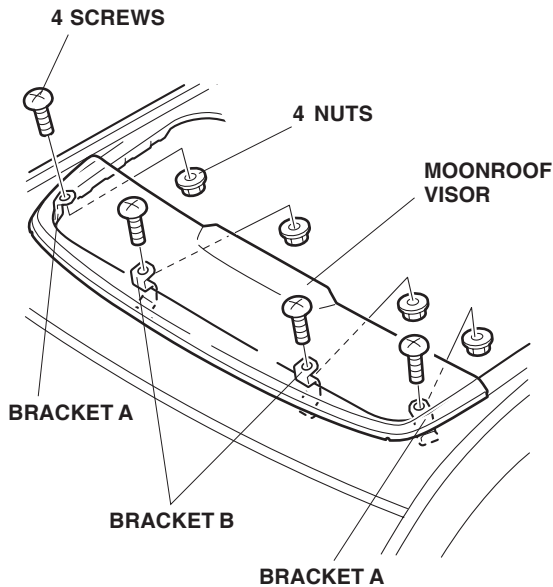

- Align the bracket B holes with the moonroof visor holes. Install the two screws and two nuts loosely onto the brackets B.

- Position the moonroof visor with equal spacing on all sides. Check that the rubber seal is not twisted or rolled under the visor.

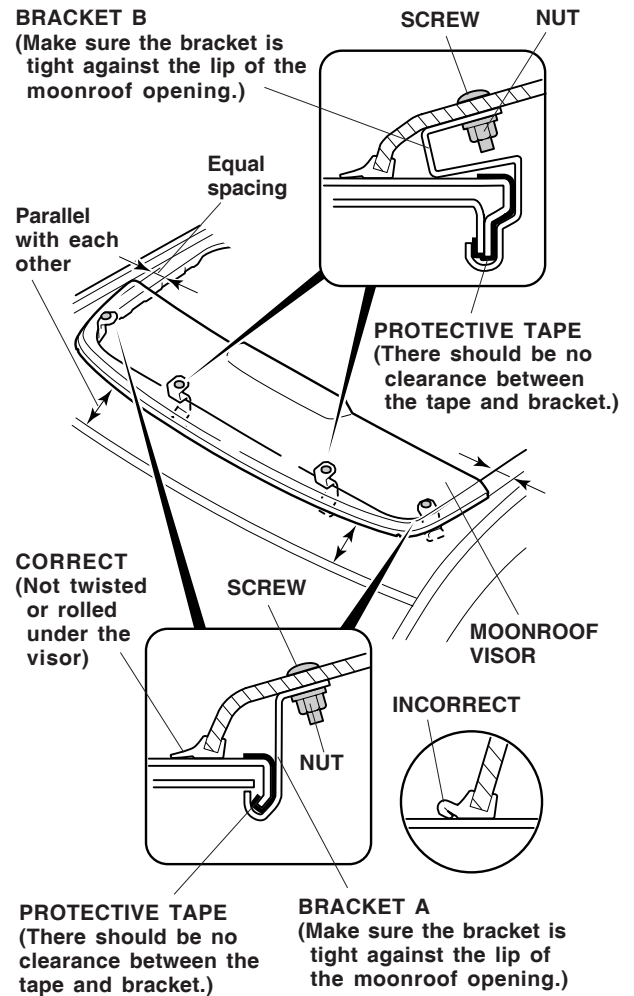

- Torque the two nuts and screws on the front of the vehicle first, then torque the two nuts and screws on the right and left sides of the vehicle. To prevent damage to the moonroof visor and the resin nuts, do not overtighten the screws.

Torque: 2 N·m (1.5 lb-ft)

CARE OF THE MOONROOF VISOR

- To avoid damaging the surface, never use ammonia-based cleaners or solvents to clean the moonroof visor.
- Clean with a solution of mild dishwashing soap and water using a soft cloth or chamois.
- To remove fine scratches and restore the original luster, use Meguiar's Mirror Glaze plastic cleaner and polish or an equivalent high-quality plastic cleaner.