



INSTALLATION INSTRUCTIONS

Accessory
CROSS BARS (BLACK)
P/N 08L04-STX-200B

Application
2010 MDX

Publications No.
BII 42096
Issue Date
JAN 2010

PARTS LIST

2 Cross bars

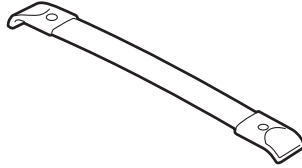

4 Joint holders

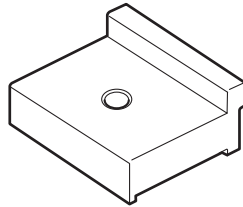

4 TORX screws

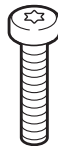

4 Washers



4 Lock washers



Accessory user's information manual

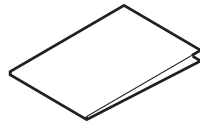

TOOLS AND SUPPLIES REQUIRED

T15 TORX screwdriver

T30 TORX screwdriver

INSTALLATION

Client Information: The information in this installation instruction is intended for use only by skilled technicians who have the proper tools, equipment, and training to correctly and safely add equipment to your vehicle. These procedures should not be attempted by "do-it-yourselfers."

NOTE:

- Wipe the roof rails clean before installing the cross bars.
 - Be careful not to damage the body paint.
1. Remove the TORX bolt from the inside rear of the right roof rail.

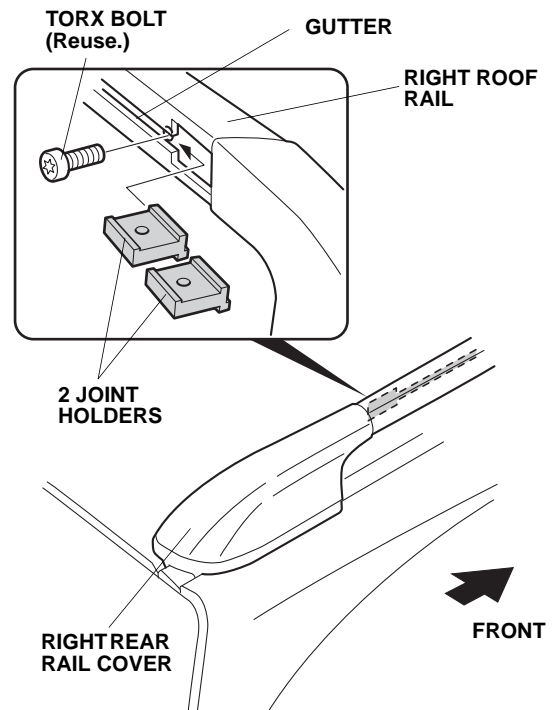

2. Slide two joint holders into the gutter of the right roof rail, and reinstall the TORX bolt securely.
3. Repeat steps 1 and 2 for the other roof rail.

- Slide each joint holder forward, and align the joint holder hole with the marks on the inside of the roof rails.

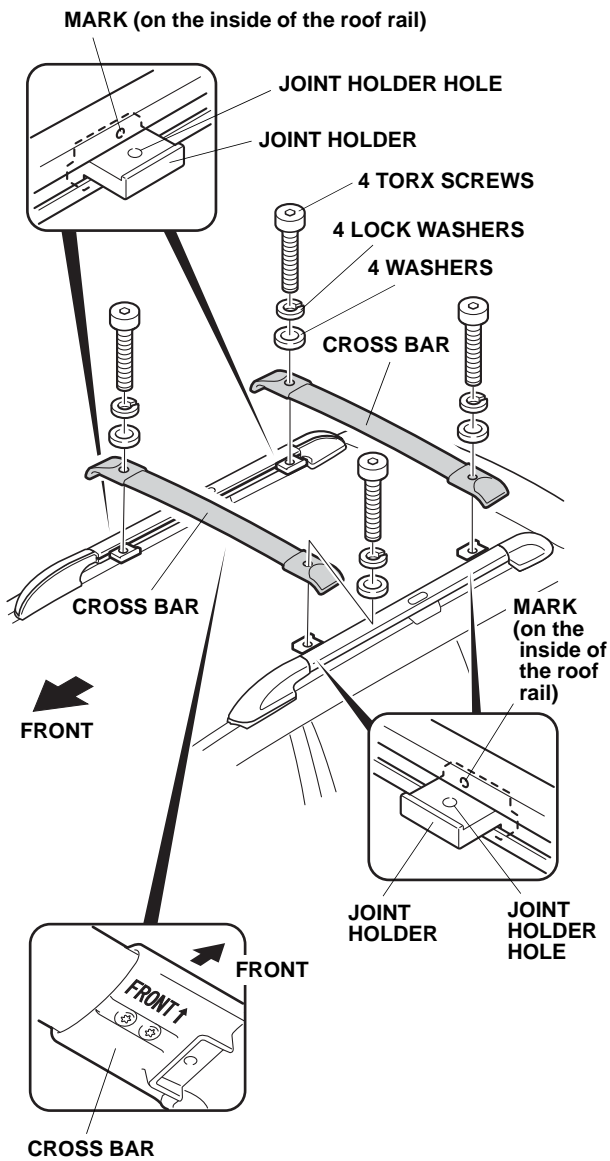

- Position the cross bars on the joint holders, and install four TORX screws with four washers and four lock washers. Tighten the TORX screws securely.

NOTE:

- If the length of the cross bar is not aligned, adjust it by moving the stay in or out as necessary. Do not loosen the cross bar TORX screws.
- If the stay is not moved, adjust it by loosening the two cross bar TORX screws. Tighten the cross bar TORX screws securely.

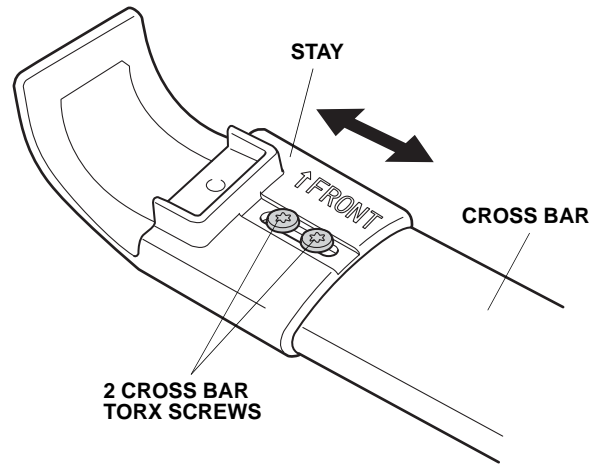

USE AND CARE

- Check the cross bars mounting bolts and screws frequently, and retighten them if necessary.
- Distribute the weight of the cargo evenly, and do not exceed the maximum weight capacity of 75 kg (165 lbs).