



ACURA INSTALLATION INSTRUCTIONS

Accessory

**HOOD AIR DEFLECTOR
P/N 08P47-STK-200A**

Application

2009 RDX

Publications No.

BII 39545

Issue Date

MAY 2008

PARTS LIST

Hood air deflector

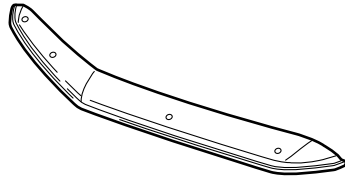

Center stopper

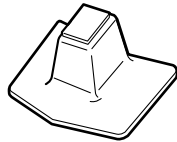

2 Brackets A

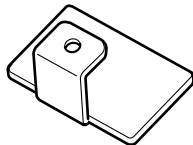

2 Brackets B

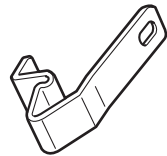

Template

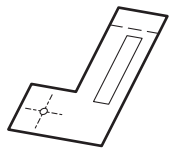

2 Collars



3 Alcohol swabs

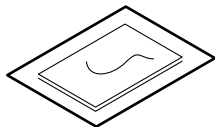

2 Clips



4 Screws



2 Rivet nuts

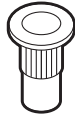

2 Protective tapes



Hood label

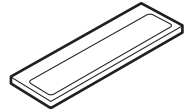

TOOLS AND SUPPLIES REQUIRED

Phillips screwdriver

Shop towel

Felt-tip pen

Scale

Drill

Drill bit (3 mm, 6 mm, and 10 mm bit)

Drill stop

Center punch

Rivet nut tool - P/N 07AAE-000A100

Touch-up paint

Eye protection (face shield, safety goggles, etc.)

Isopropyl alcohol

19 mm Wrench

Hex wrench

INSTALLATION

Client Information: The information in this installation instruction is intended for use only by skilled technicians who have the proper tools, equipment, and training to correctly and safely add equipment to your vehicle. These procedures should not be attempted by “do-it-yourselfers.”

NOTE:

- Be careful not to damage the body finish when you install the hood air deflector.
- This hood air deflector should be installed only when the ambient air temperature is above 15°C (60°F).
- To allow the adhesive to cure, do not wash the vehicle for 24 hours.

1. Fold the template as shown.
2. Position the template in the position shown by aligning it with the hole of the hood.

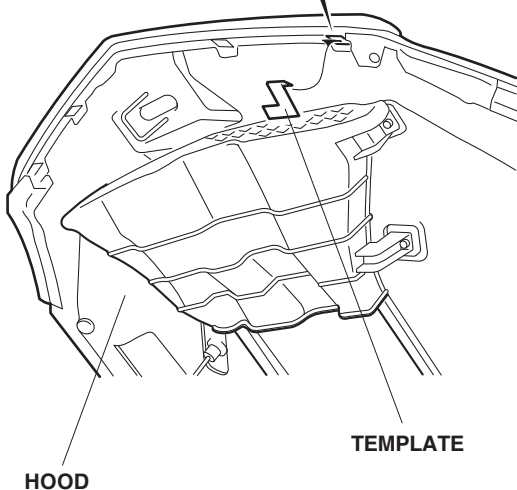
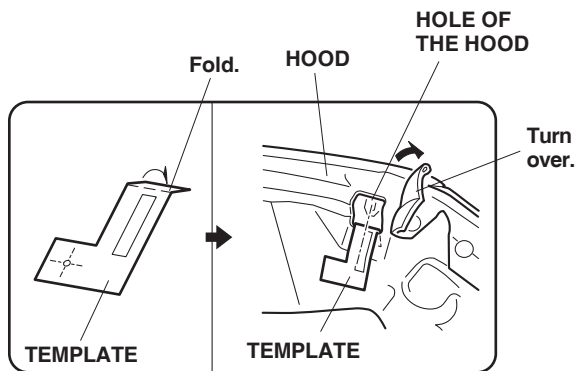

3. Using a felt-tip pen, mark the hood as shown. Remove the template.

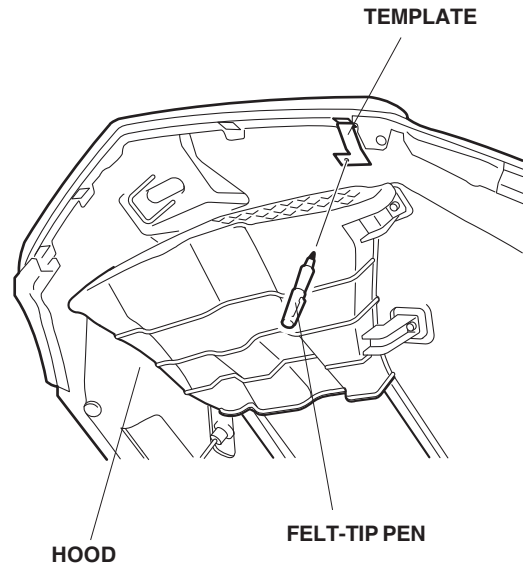

4. Lightly center-punch the mark on the hood. While wearing eye protection, first drill with a 3 mm drill bit, next drill with a 6 mm drill bit and finish with a 10 mm drill bit.
 - To prevent drilling through the hood, wrap drill stop around the drill bit 10 mm away from the tip.
 - Remove all burrs and metal shavings, and apply touch-up paint to the edge of the hole you drilled.

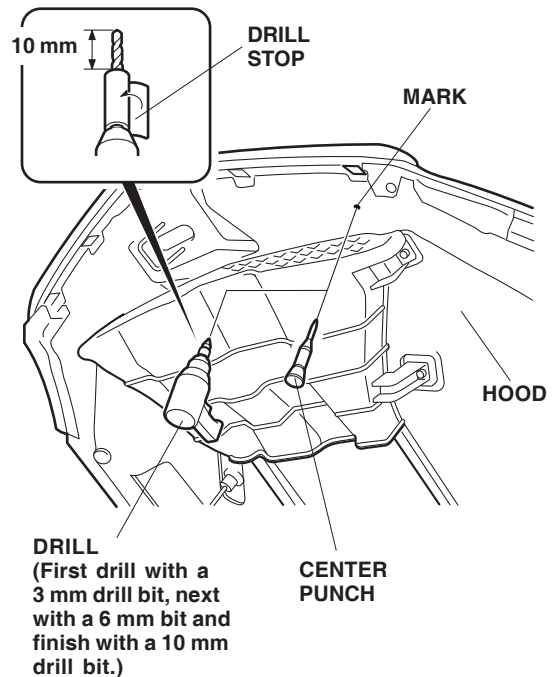

5. Install the rivet nuts:
 - Thread one rivet nut onto the mandrel of the rivet nut tool as shown.

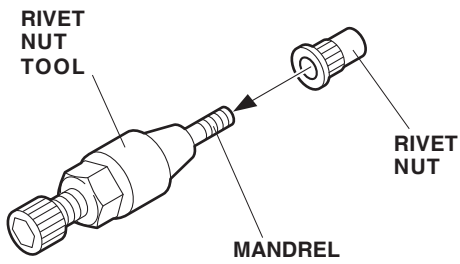

- Insert the rivet nut into the hole in the vehicle panel and install the hex wrench on the rivet nut tool.

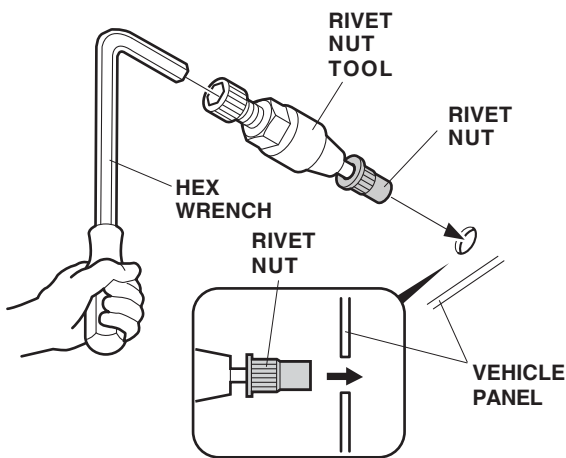

- Holding the rivet nut tool with the hex wrench, turn the 19 mm wrench clockwise and install the rivet nut on the vehicle panel.

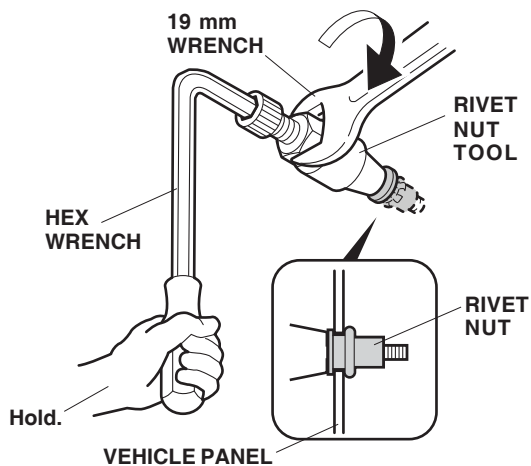

- Remove the rivet nut tool from the rivet nut by turning the hex wrench counterclockwise.

6. Measure the hood and mark the measured point with a felt-tip pen.

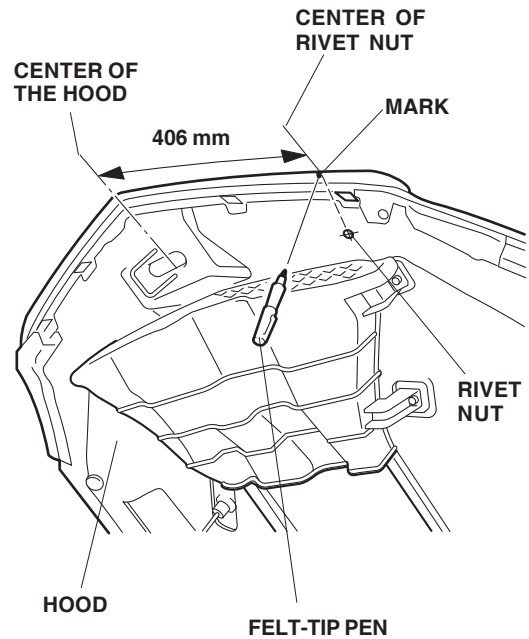

7. Using an alcohol swab, clean the area where the protective tape will attach. Attach the protective tape around the front edge of the hood starting at the location shown.

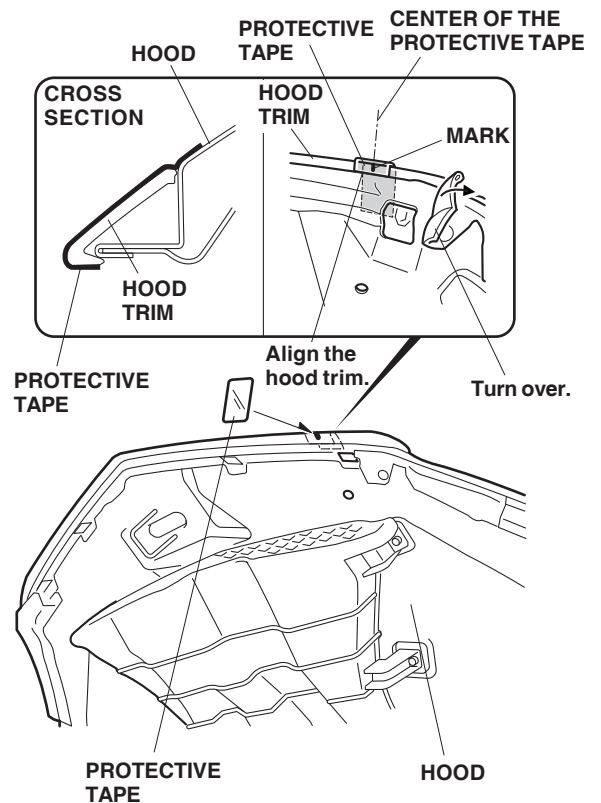

8. Place bracket B over the hood around the protective tape, and install the screw. Push bracket B against the hood while installing the screw. Do not tighten the screw at this time.

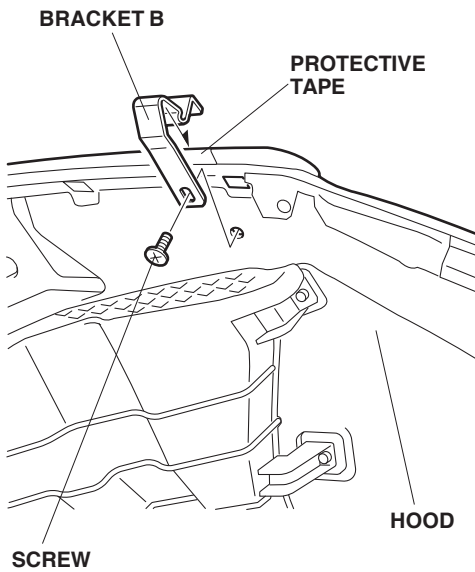

9. Repeat steps 1 thru 8 to install a rivet nut and a bracket on the right side of the hood.
10. Using an alcohol swab, clean the hood between the two brackets. Let the alcohol dry before proceeding.

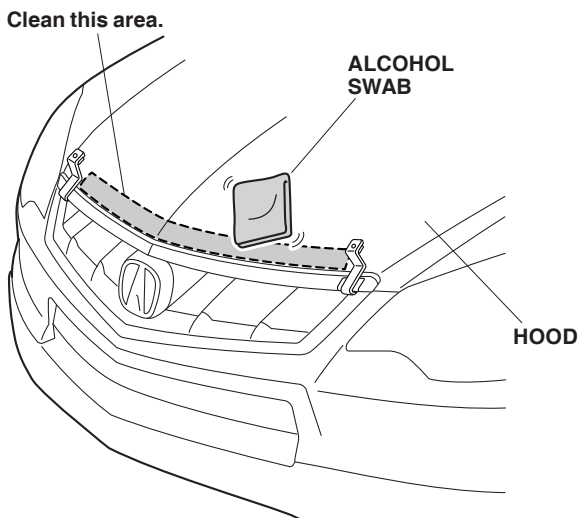

11. Remove the adhesive backing from bracket A and attach to the hood at the measurement shown. With your hand, firmly press down the entire surface of the adhesive.

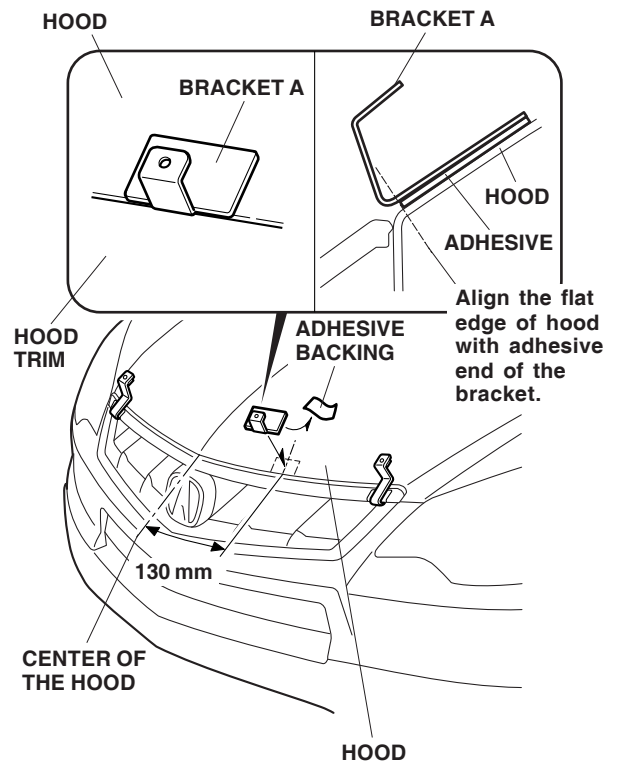

12. Repeat step 11 to install bracket A on the right side of the hood.
13. Remove two adhesive backings from the center stopper and attach it to the center of the hood. With your hand, firmly press down the entire surface of the adhesive.

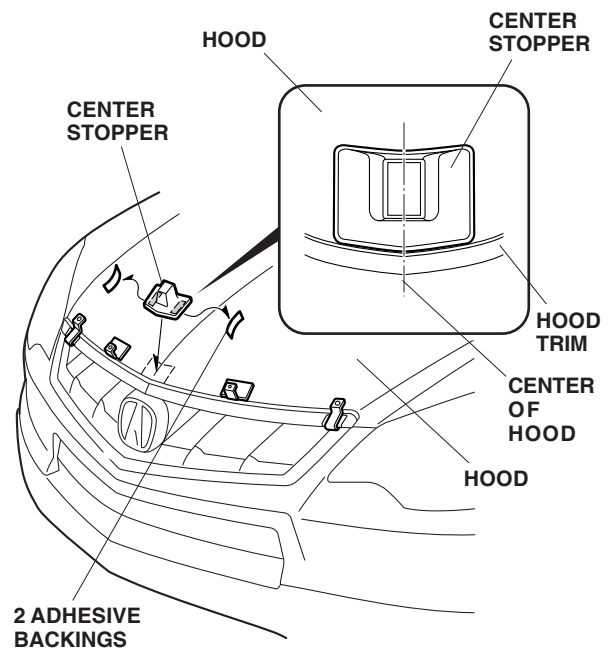

- Align the holes in the air deflector with the holes in the two brackets A and two brackets B. Install the two clips, two screws, and two collars, then tighten the screws securely.

NOTE: Make sure that the front end of the molding is not tucked under.

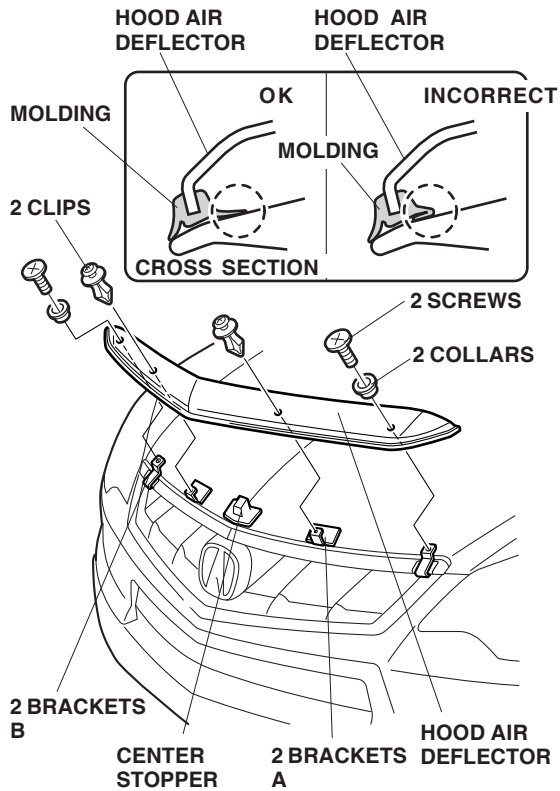

- Open the hood, and check that there is no clearance between brackets B and the hood.

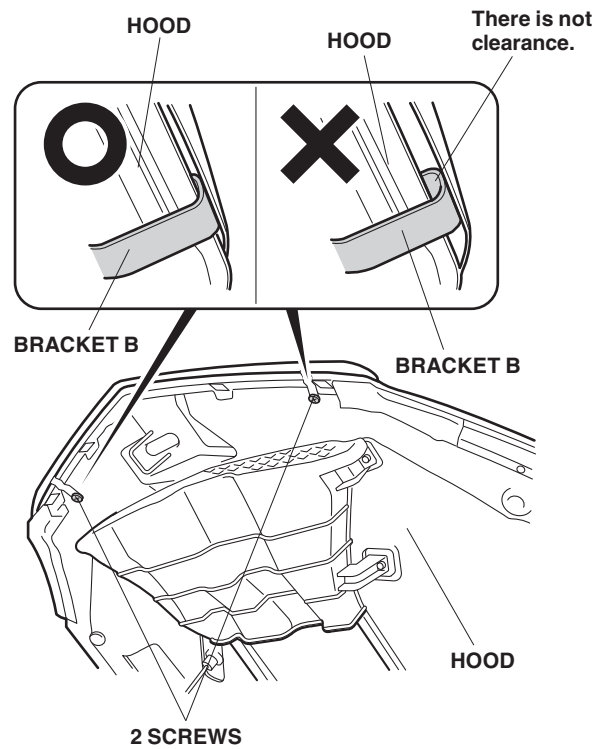

- Tighten the screw you installed in step 8.
- Use the remaining alcohol swab to clean the area where the hood label will attach.

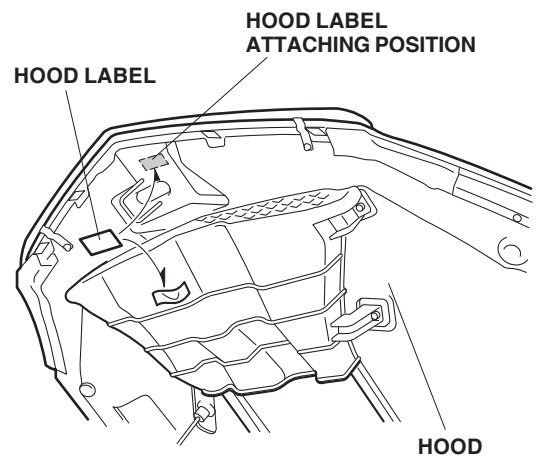

- Remove the adhesive backing from the hood label and attach it to the hood in the area shown.