



INSTALLATION INSTRUCTIONS

Accessory
FRONT UNDER SPOILER

Application
2009 RDX

Publications No.
BII 39553

Issue Date
MAY 2008

PARTS LIST

Front under spoiler

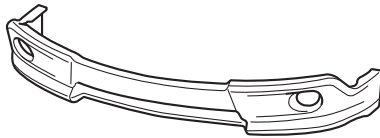

2 Covers

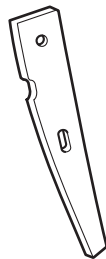

4 Clips



4 Washers



TOOLS AND SUPPLIES REQUIRED

Phillips screwdriver
Flat-tip screwdriver
Drill
Drill bits (3 mm, 5 mm)
Clip remover
Eye protection (face shield, safety goggles, etc.)
Blanket
Utility knife
File
Pushpin
Tape measure

INSTALLATION

Client Information: The information in this installation instruction is intended for use only by skilled technicians who have the proper tools, equipment, and training to correctly and safely add equipment to your vehicle. These procedures should not be attempted by “do-it-yourselfers.”

NOTE:

- Be careful not to damage the front bumper and body paint finish.
1. Make sure you have the anti-theft code for the radio, then write down the frequencies for the preset buttons.
 2. Disconnect the negative cable from the battery.
 3. Open the hood. Remove the six clips (four short clips and two long clips) from the front bulkhead cover.

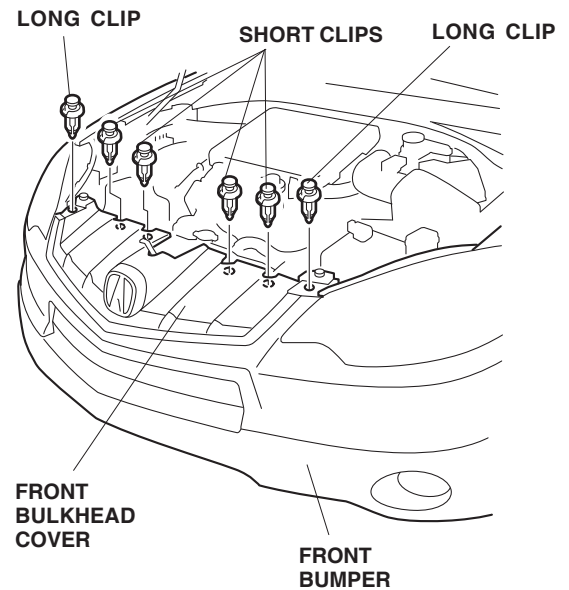

4. Remove the front bumper (six self-tapping screws, three short clips, four long clips, and unplug the fog light connectors).

- Have an assistant help you when removing and installing the front bumper.
- Set the front bumper on the blanket to prevent damage.

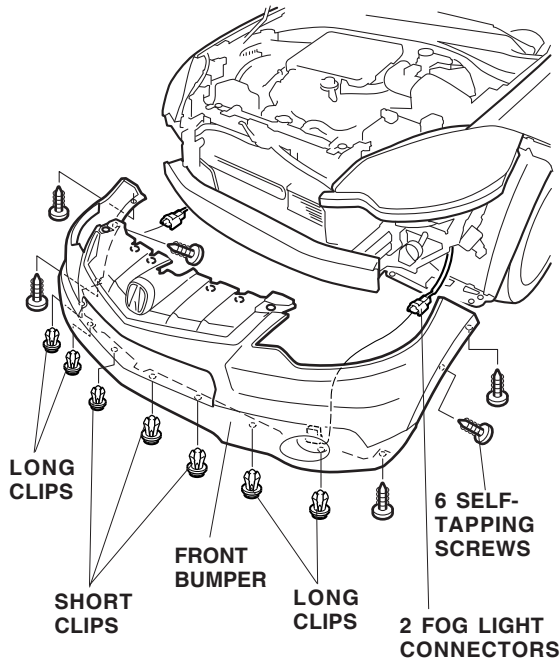

5. Remove the left fog light from the front bumper (three self-tapping screws).

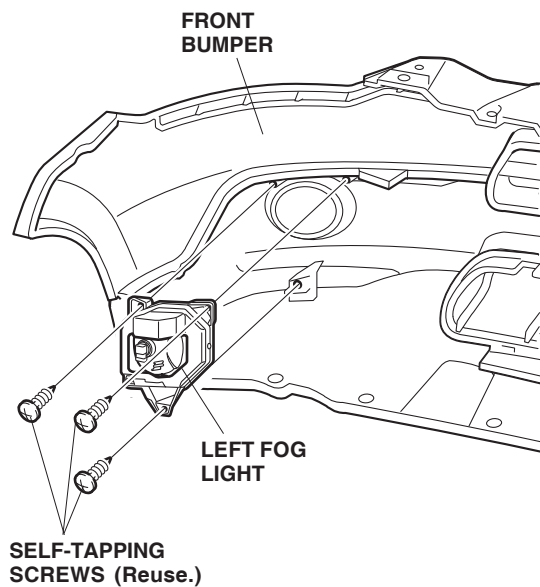

6. Remove the right fog light the same way.

7. Release the 14 tabs and separate the front bumper (two clips and two bolts).

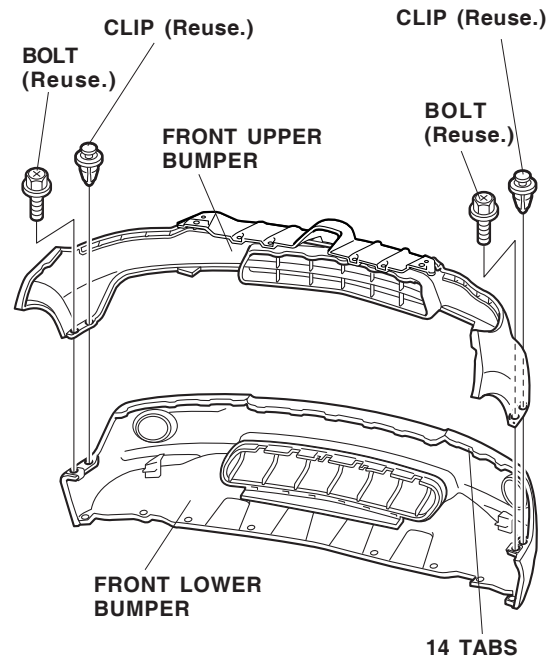

8. Remove the two spring nuts from the front lower bumper.

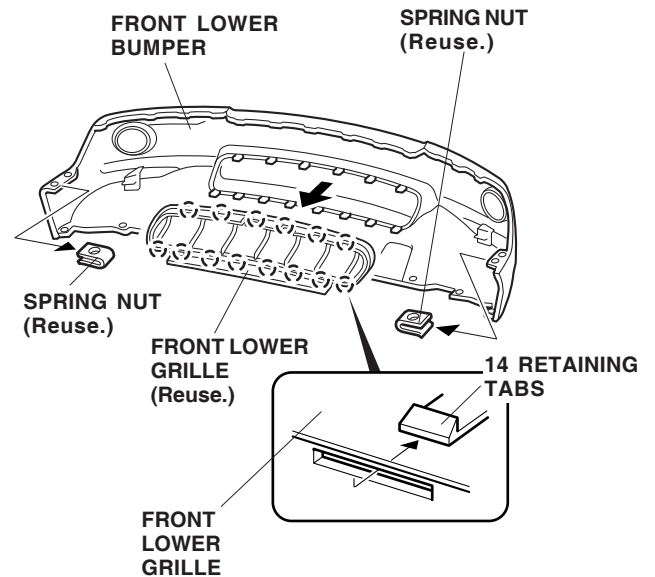

9. Remove the front lower grille from the front lower bumper (14 retaining tabs).

- Slide the two spring nuts (from step 8) onto the front under spoiler.

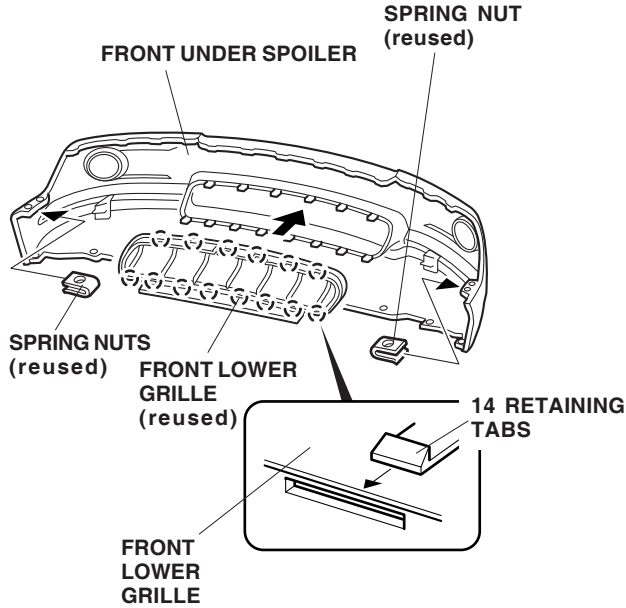

- Install the front lower grille (removed in step 9) on the front under spoiler.
- Install the front under spoiler on the front upper bumper using the two clips and two bolts from step 7.

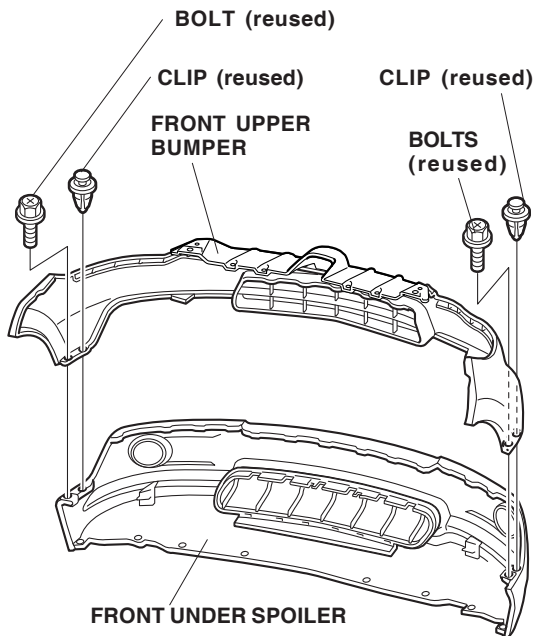

- Reinstall the left fog light to the front bumper with the three self-tapping screws.

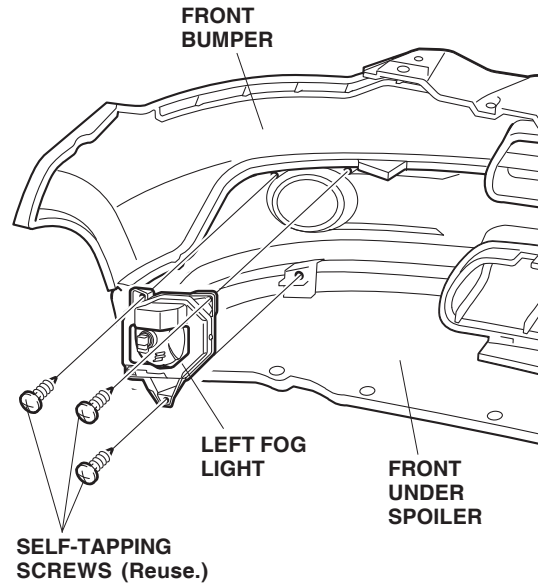

- Repeat step 13 to reinstall the right fog light.
- Position the cover on the left front inner fender. Mark the left front inner fender through the holes in the cover, and make a hole through each mark with a pushpin. Mark the center of the lower hole.

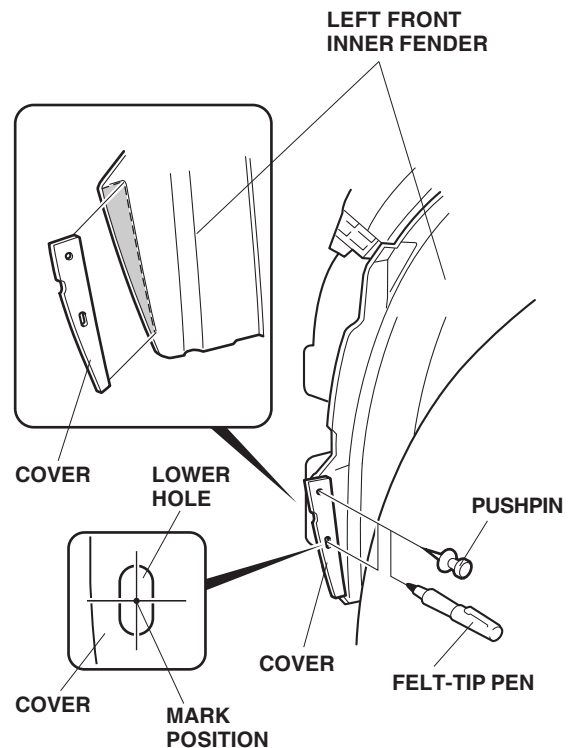

16. While wearing eye protection, drill a 3 mm hole through each marked location at the left front inner fender. First with a 3 mm drill bit, and finish with a 5 mm drill bit. Remove any burrs from the edges of the holes with a file.

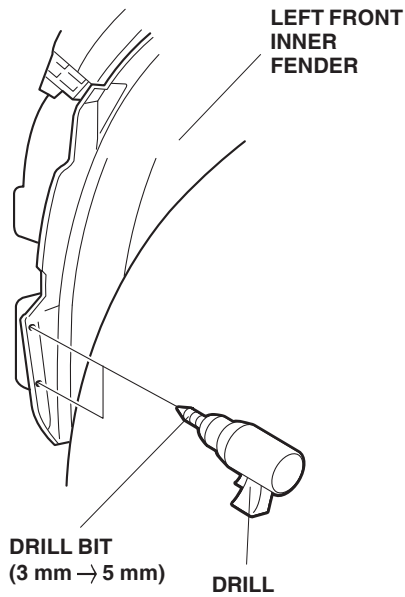

17. Measure the left front inner fender from the center of the hole to the inner fender, and place a mark at each measuring point. Using a utility knife, cut the inner fender at each marked point.

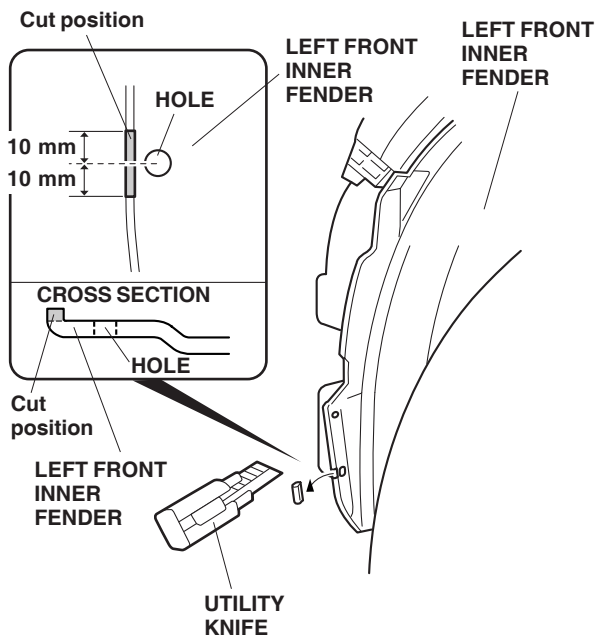

18. Position the cover on the left front inner fender, and install the two clips and two washers.

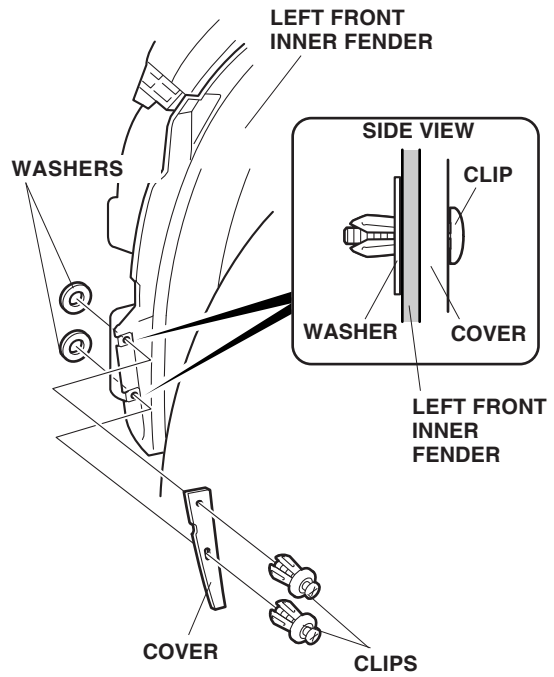

19. Repeat steps 15 through 18 to install the right side cover.

20. Reinstall the front bumper.

21. Check that all wire harnesses are routed properly and all connectors are plugged in.

22. Connect the negative cable to the battery and reset the radio and client's radio station presets.

NOTE: When the battery is disconnected, the driver's window AUTO function is disabled.

- Start the engine. Push down on the driver's window switch until the window is fully open.
- Pull up on the driver's window switch to close the window completely, then hold the switch for 2 seconds or more.
- Lower and raise the driver's window to check operation of the driver's window AUTO function.