

Accessory	Application	Publications No.
<b>SPLASH GUARD</b>	<b>2008 TSX</b>	<b>BII 37245</b>
		Issue Date
		<b>JUNE 2007</b>

**PARTS LIST**

Left front splash guard

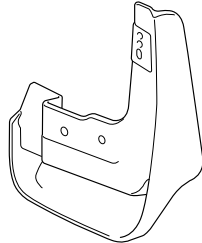

Right front splash guard

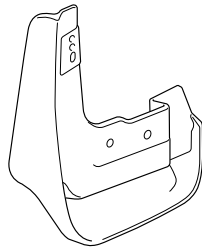

Left rear splash guard

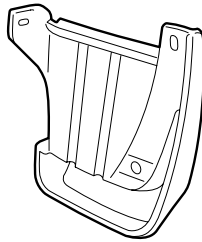

Right rear splash guard

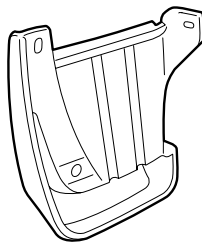

8 Self-tapping screws

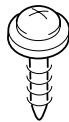

2 Spring nuts



**TOOLS AND SUPPLIES REQUIRED**

- Phillips screwdriver
- Stubby Phillips screwdriver
- Pushpin

**INSTALLATION**

**NOTE:**

- These instructions show the left side splash guards being installed, the same procedure applies to installing right side splash guards.

**Installing the Front Splash Guards**

1. Turn the steering wheel all the way counterclockwise.
2. Remove and retain the two self-tapping screws that fasten the left front inner fender to the front fender and fender well.
3. Using the pushpin, pierce a hole through the center of the inner fender well retaining clip, as shown.

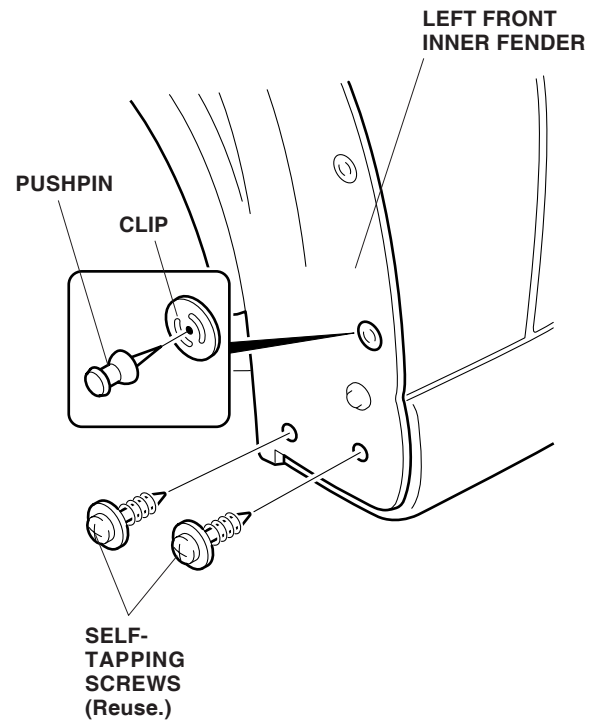

- Position the left front splash guard on the left front inner fender and loosely install the two self-tapping screws removed in step 2 and one self-tapping screw from the kit. Align the recess on the splash guard with the projection on the bottom of the body as shown.
- Tighten the three self-tapping screws installed in step 4 in the order of **1**, **2**, and **3**. After tightening, check that there is no clearance between the splash guard and body.

**NOTE:** If there is clearance between the splash guard and body, loosen the three self-tapping screws that fasten the splash guard to the inner fender and fender well, and one self-tapping screw that fastens the inner fender to the fender well, relocate the splash guard on the inner fender, then retighten the self-tapping screws.

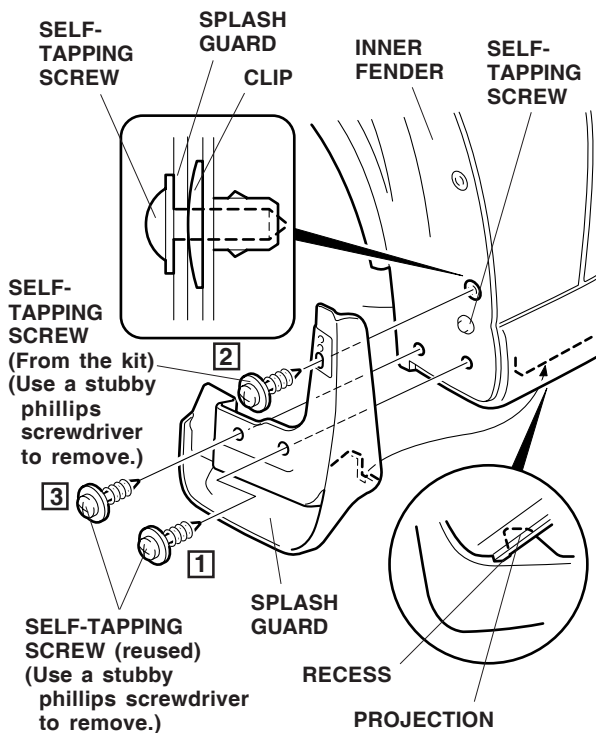

- Turn the steering wheel all the way clockwise, and repeat step 2 through 5 to install the right front splash guard.

## Installing the Rear Splash Guards

- Remove the self-tapping screw from the rear bumper.
- Slide one spring nut over the dimpled area of the rear bumper. If the clip nut is loose, squeeze the ends together so that it fits snug onto the rear bumper.
- Using a pushpin, pierce a hole through the center of the inner fender well retaining clip, as shown.
- Using a pushpin pierce a hole through the dimpled spot in the rear bumper.

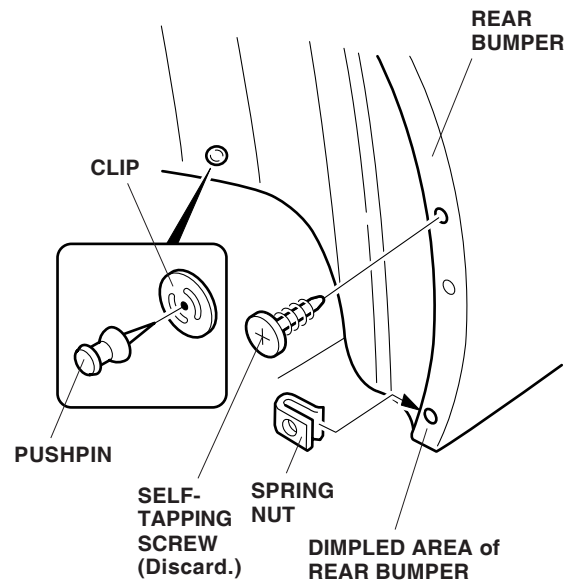

11. Position the left rear splash guard on the rear bumper, and install three self-tapping screws from the kit.
12. Tighten the self-tapping screws in the order of **1**, **2**, and **3**. After tightening, check that there is no clearance between the splash guard and body.

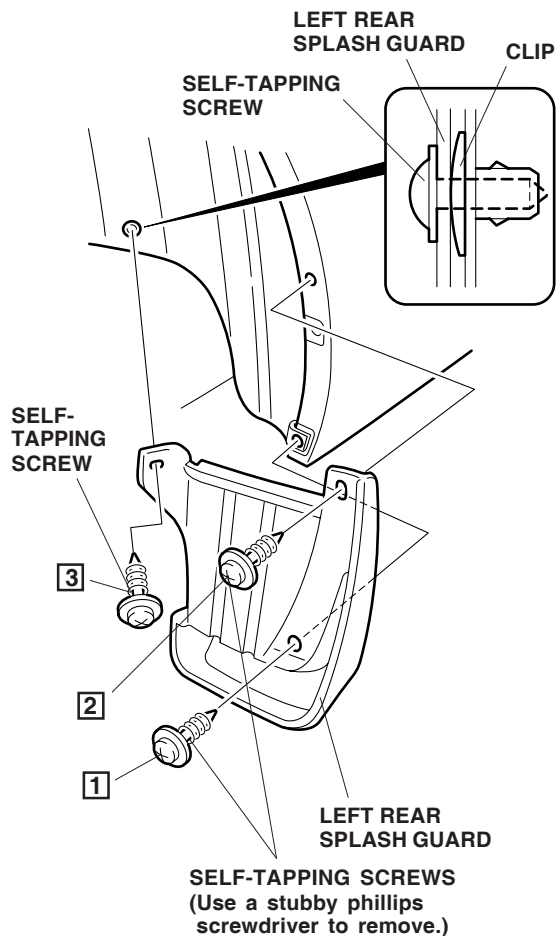

13. Repeat step 7 through 12 to install the right rear splash guard.