



# ACURA INSTALLATION INSTRUCTIONS

Accessory

**GOLD EMBLEM  
P/N 08F20-STK-200**

Application

**2008 RDX**

Publications No.

**BII 37430**

Issue Date

**JUL 2007**

## PARTS LIST

Front gold "A" emblem

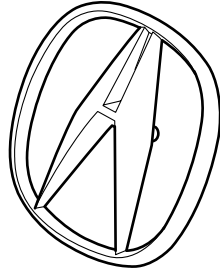

Rear gold "A" emblem

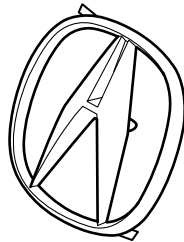

Rear gold "ACURA" emblem

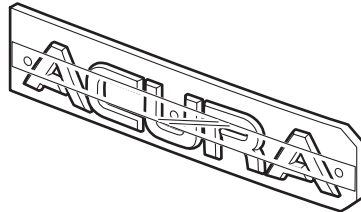

Rear gold "RDX" emblem

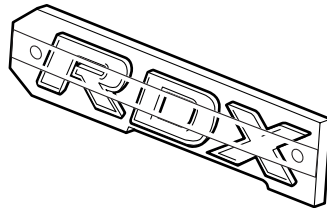

Rear gold "SH-AWD" emblem

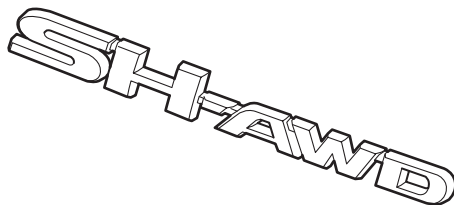

Rear gold "TURBO" emblem



## TOOLS AND SUPPLIES REQUIRED

- Phillips screwdriver
- Shop towel
- Masking tape
- Isopropyl alcohol
- Needle-nose pliers
- String
- Stubby Phillips screwdriver
- Blanket

## INSTALLATION

**Client Information:** The information in this installation instruction is intended for use only by skilled technicians who have the proper tools, equipment, and training to correctly and safely add equipment to your vehicle. These procedures should not be attempted by "do-it-yourselfers."

### NOTE:

- Be careful not to damage the body paint.
- This emblem kit should only be installed if the ambient air temperature is 60°F (15°C) or above.
- To allow the adhesive to "cure," do not wash the vehicle for 24 hours.

## Installing the Front Gold "A" Emblem

1. Make sure you have the anti-theft code for the radio, then write down the frequencies for the preset buttons.
2. Disconnect the negative cable from the battery.
3. Open the hood. Remove the six clips (four short clips and two long clips) from the front bulkhead cover.

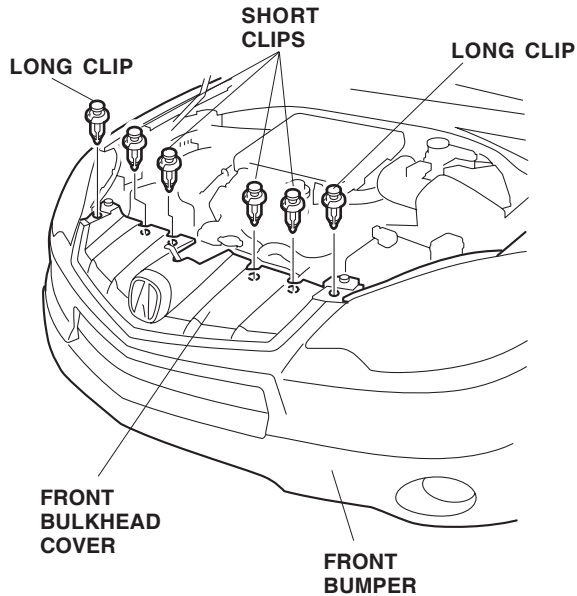

4. Remove the front bumper (six self-tapping screws, three short clips, four long clips, and unplug the fog light connectors).
  - Have an assistant help you when removing and installing the front bumper.
  - Set the front bumper on the blanket to prevent damage.

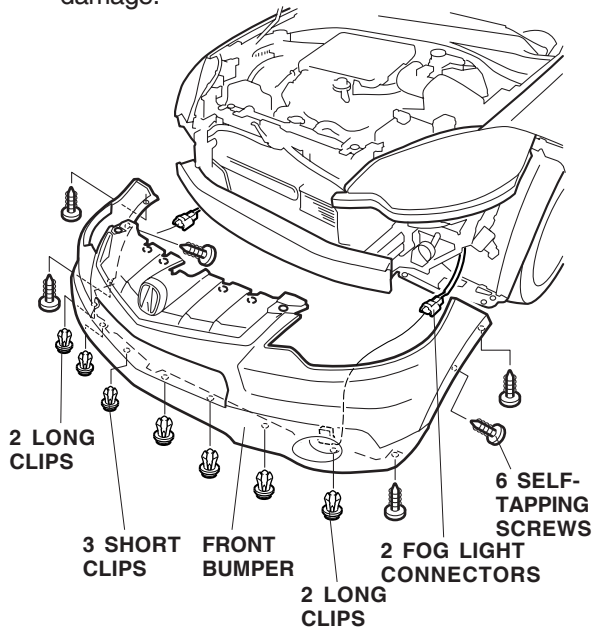

5. Remove the two self-tapping screws that secure the existing "A" emblem and remove the "A" emblem.

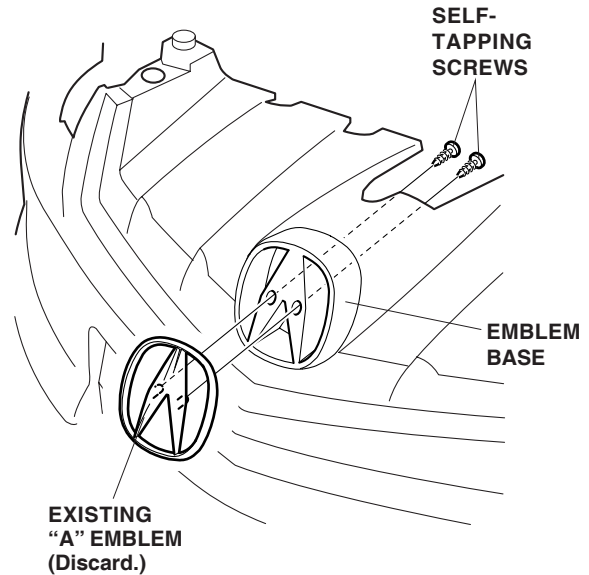

6. Slide the pins on the new front gold "A" emblem into the holes in the emblem base and install the two self-tapping screws you just removed.

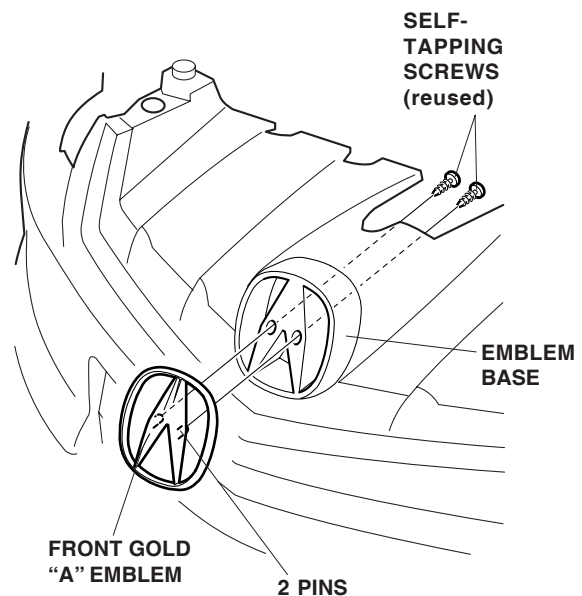

## Installing the Rear Gold “A” and “SH-AWD” Emblems

- To prevent damage to the paint and to help you position the gold emblems, attach masking tape around the existing rear “A” and “SH-AWD” emblems.

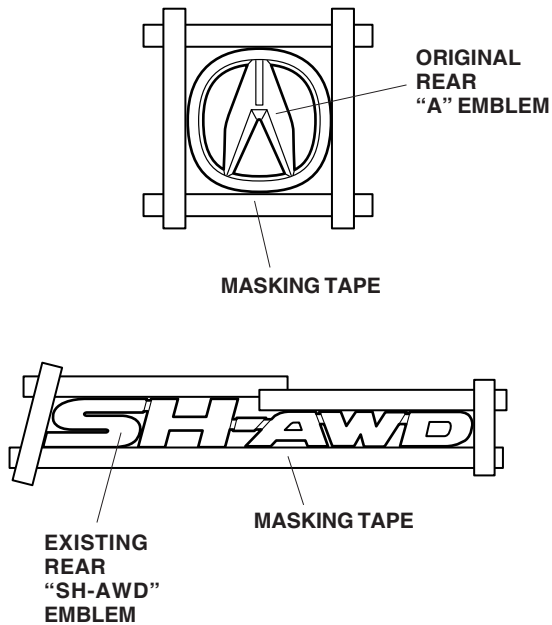

- Remove the existing emblems by cutting the outer edges with a piece of string.

**NOTE:** The location of the retaining pins on the back of existing “A” emblem when cutting the edges.

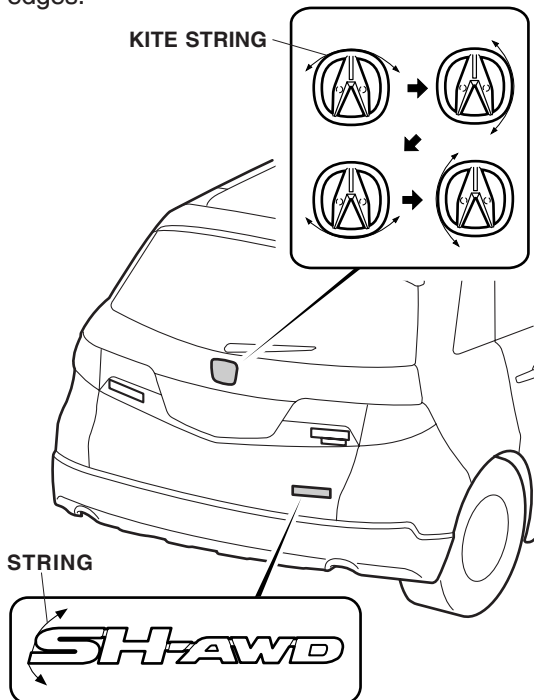

- Remove the original rear “A” and “SH-AWD” emblems.
- If any clip(s) for the “A” emblem remained on the vehicle body panel, remove the clip(s) with needle nose pliers.

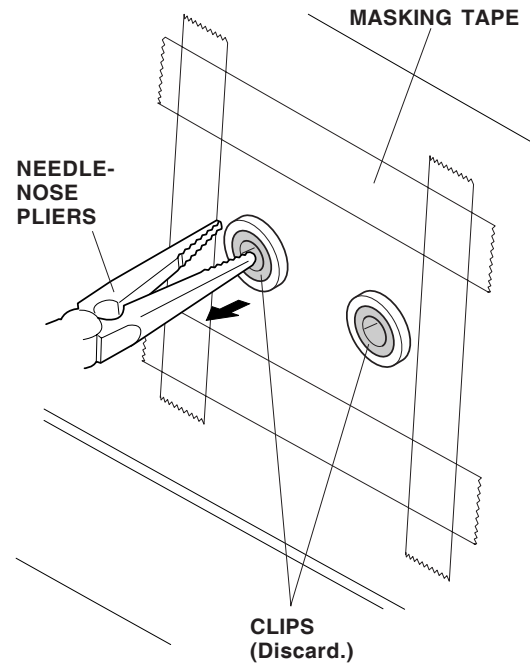

- Using isopropyl alcohol on a shop towel, thoroughly clean the areas where the rear gold emblems will attach.

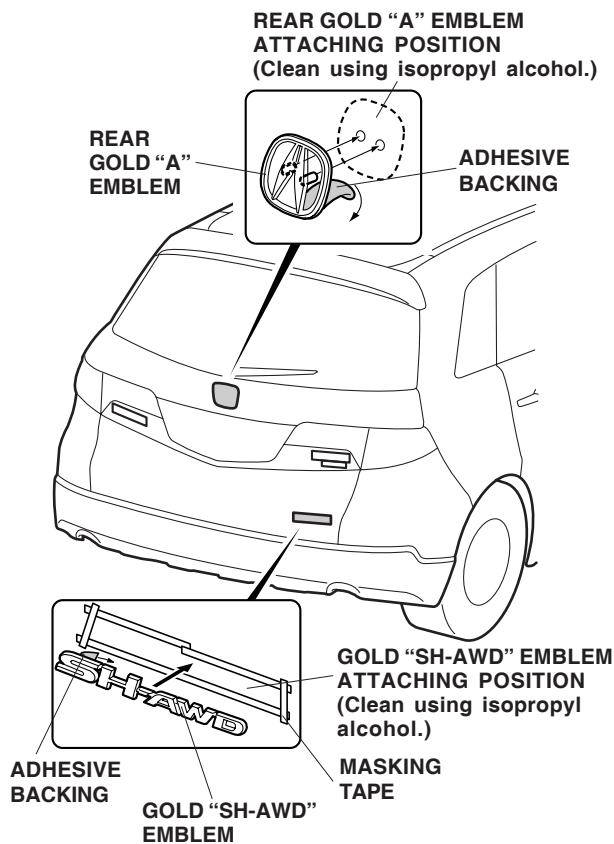

- Remove the adhesive backings from the rear gold "A" and "SH-AWD" emblems, and attach them to the tailgate so they line up with the masking tape. Hold the gold emblems firmly against the trunk lid with the palm of your hand for 30 seconds.
- Remove the masking tape.

### Installing the Rear Gold "ACURA" Emblem

- Remove the film from the rear gold "ACURA" emblem. Remove the rear gold "ACURA" emblem from the guide form.

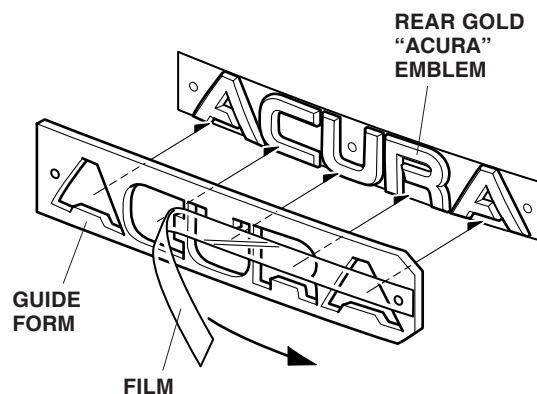

- Position the guide form over the existing rear "ACURA" emblem on the vehicle.

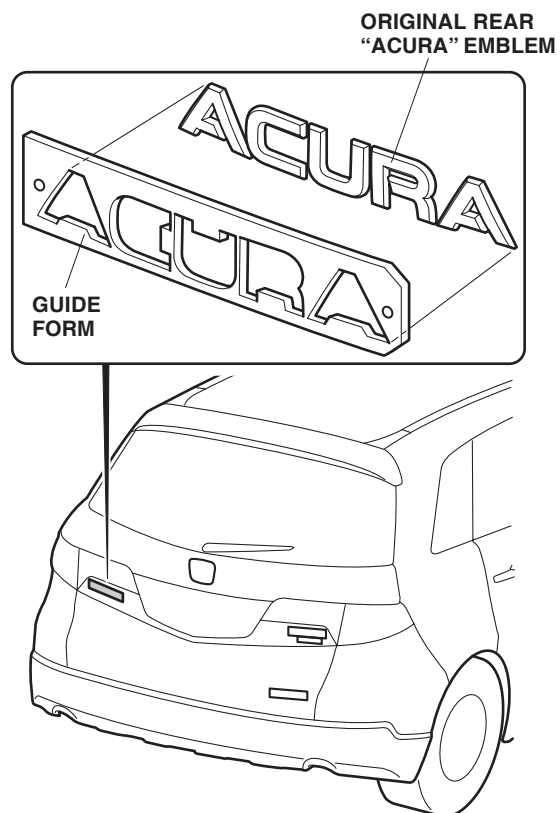

16. Attach the masking tape around the guide form.

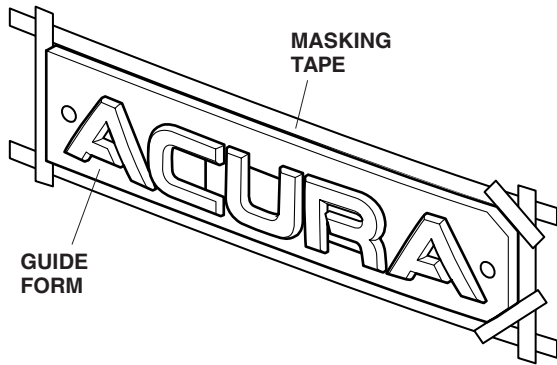

17. Remove the guide form. Remove the existing emblem by cutting the outer edges with a piece of string, and remove the rear "ACURA" emblem.

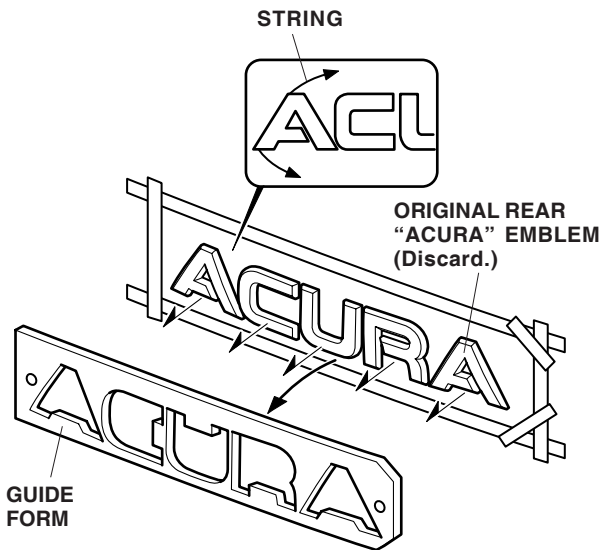

18. Place the rear gold "ACURA" emblem you removed in step 14 back into the guide form, and temporarily secure it with masking tape.

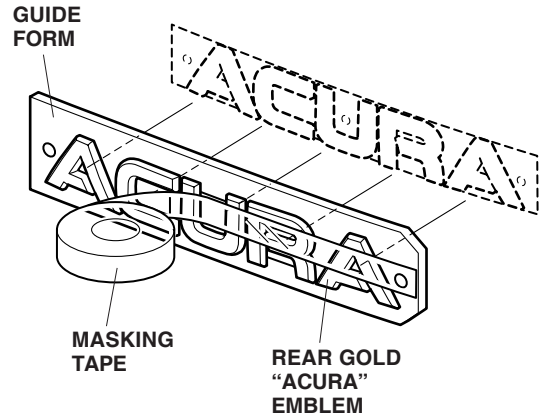

19. Using isopropyl alcohol on a shop towel, thoroughly clean the area where the rear gold "ACURA" emblem will attach.

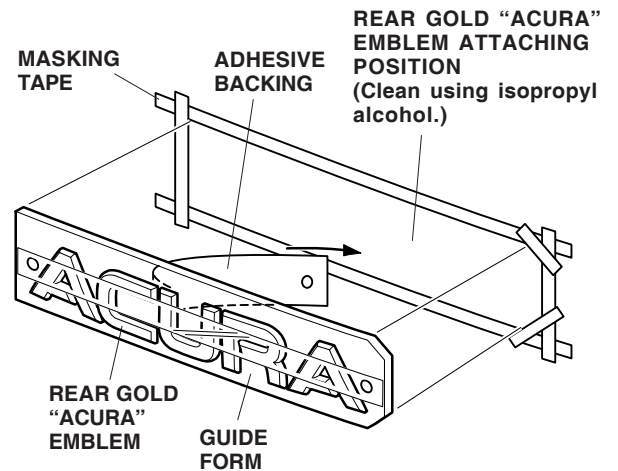

20. Remove the adhesive backing from the rear gold "ACURA" emblem, and attach it to the trunk lid while aligning the guide form with the masking tape. Hold the gold emblem firmly against the trunk lid with the palm of your hand for 30 seconds.

21. Remove the guide form and masking tape.

### Installing the Rear Gold "RDX" Emblem and Rear Gold "TURBO" Emblem

22. To prevent damage to the paint and to help you position the gold emblem, attach masking tape around the rear "TURBO" emblem as shown.

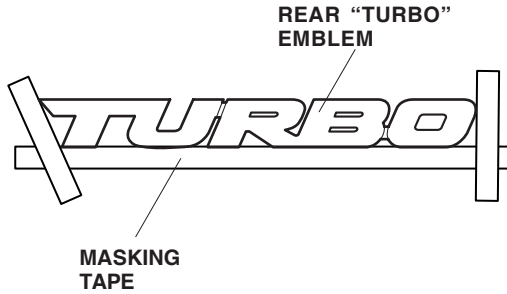

23. Remove the "TURBO" emblem by cutting the outer edges with a piece of string.

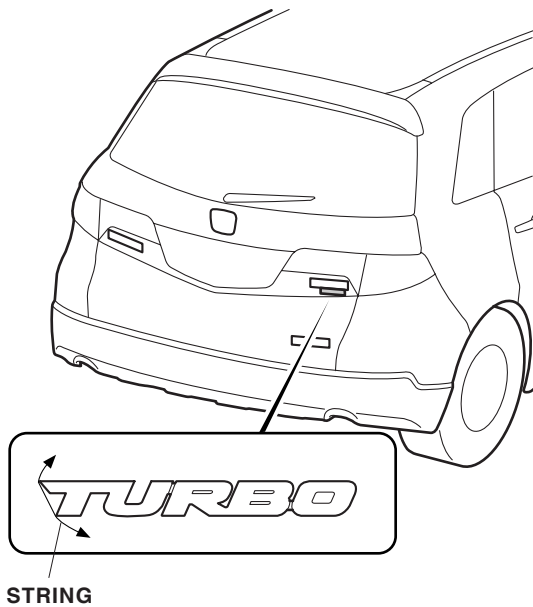

24. Remove the film from the gold "RDX" emblem. Remove the rear gold "RDX" emblem from the guide form.

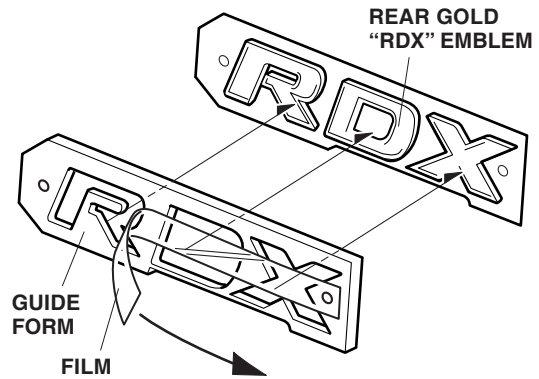

25. Position the guide form over the rear "RDX" emblem on the vehicle.

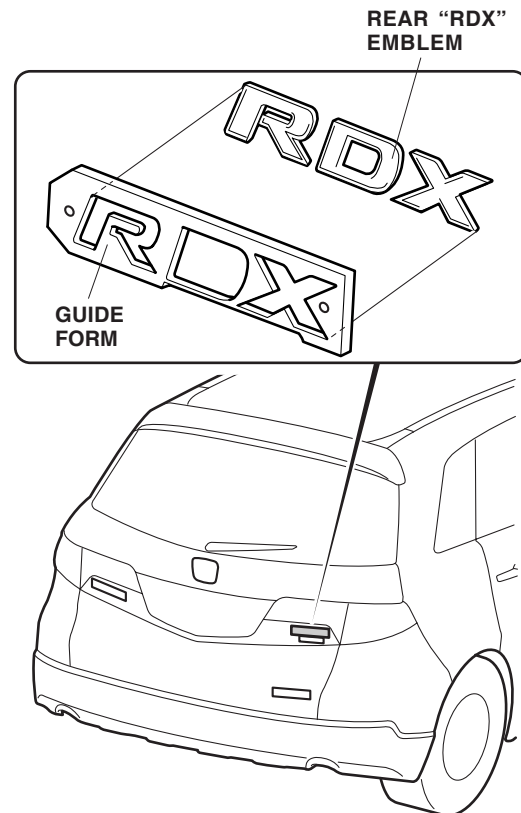

26. Attach the masking tape around the guide form as shown.

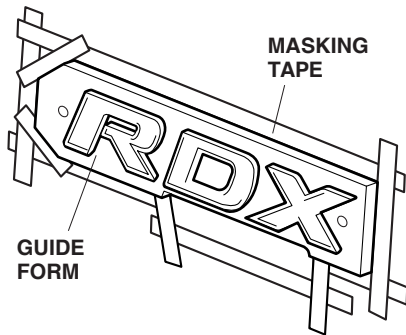

27. Remove the guide form. Remove the original emblem by cutting the outer edges with a piece of string, and remove the rear "RDx" emblem.

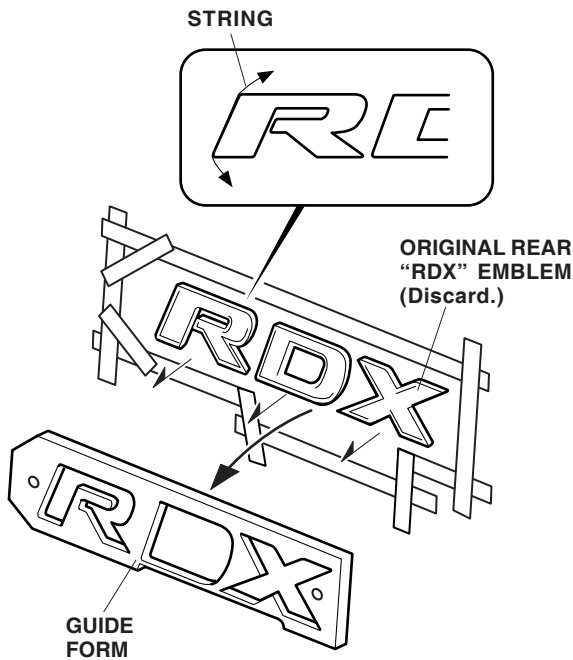

28. Set the rear gold "RDx" emblem you removed in step 24 in the guide form, and temporarily secure it with masking tape.

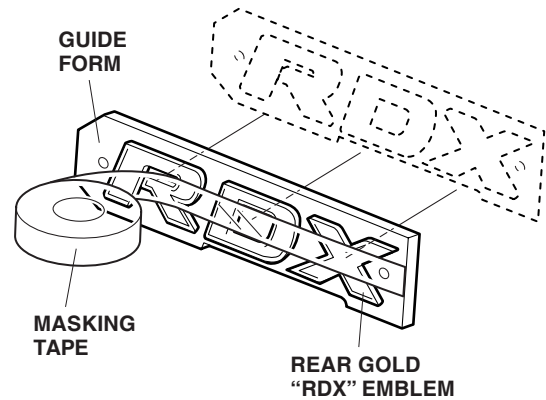

29. Using isopropyl alcohol on a shop towel, thoroughly clean the area where the gold "RDx" emblem will attach.

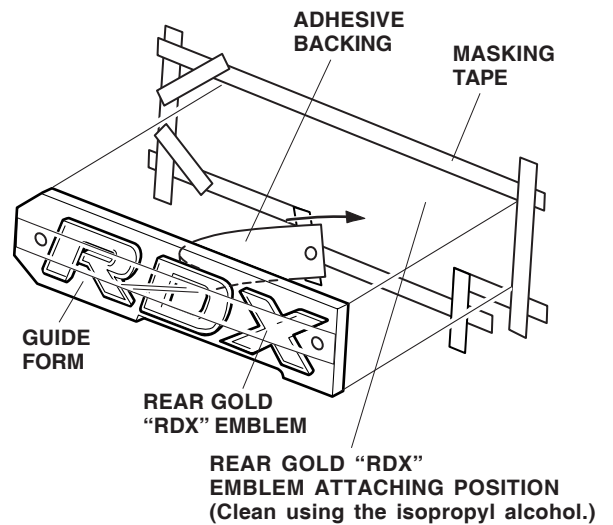

30. Remove the adhesive backing from the rear gold "RDx" emblem and attach it to the trunk lid while aligning the guide form with masking tape. Hold the gold emblem firmly against the trunk lid with the palm of your hand for 30 seconds.

31. Using isopropyl alcohol on a shop towel, thoroughly clean the area where the rear gold emblem will attach.

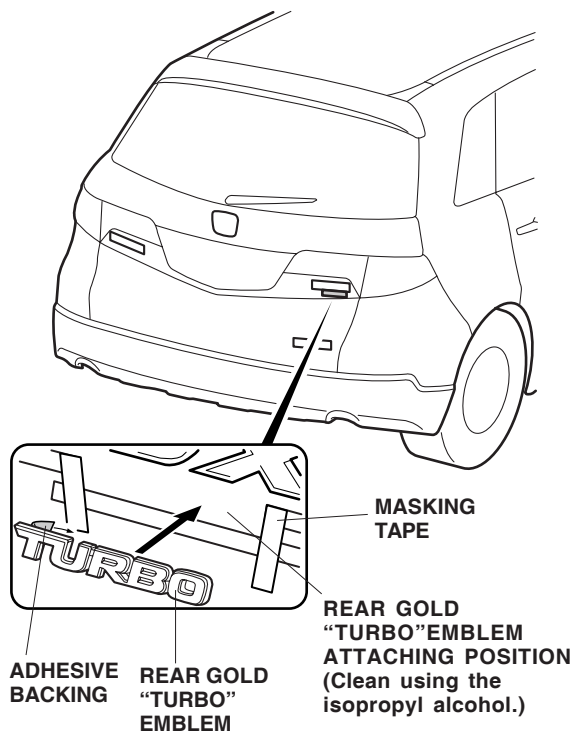

32. Remove the adhesive backing from the rear gold "TURBO" emblem, and attach it to the trunk lid so they line up with the tape. Hold the gold emblem firmly against the trunk lid with the palm of your hand for 30 seconds.
33. Remove the guide form and masking tapes.