

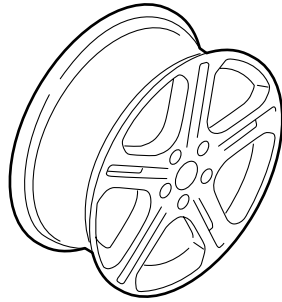

INSTALLATION INSTRUCTIONS	Accessory	Application	Publications No. BII 33722
	17" ALUMINUM WHEEL P/N 08W17-SEC-200D P/N 08W17-SEC-200E	2007 TSX	Issue Date SEP 2006

PARTS LIST

Aluminum wheel
(The illustration may differ
from the actual wheel.)



Wheel center cap
(The illustration may differ from the
actual center cap.)

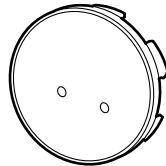

Center cap emblem

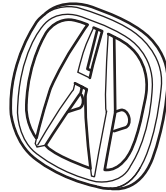

2 Push nuts

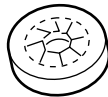

Grommet



Important information

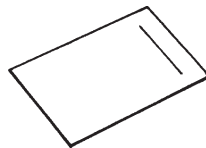

Wheel cleaning information
(Contained in the kit of
08W17-SEC-200E only.
Give this information to
your customer.)

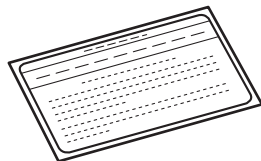

SUPPLIES REQUIRED

- Ratchet wrench
- 11 mm Socket
- Torque wrench
- Isopropyl alcohol
- Shop towel

INSTALLATION

Customer Information: The information in this installation instruction is intended for use only by skilled technicians who have the proper tools, equipment, and training to correctly and safely add equipment to your vehicle. These procedures should not be attempted by “do-it-yourselfers”.

NOTE:

- This aluminum wheel is designed for use on the TPMS (Tire Pressure Monitoring System) vehicles.
 - This aluminum wheel is equipped with the TPMS sensor. See the Service Manual for tire replacement procedure and TPMS sensor installation procedure (paragraph of Tire Pressure Sensor Replacement).
 - The illustration of the aluminum wheels shown are for reference purposes only.
 - Install the correct size tire.
 - Use a tire changer to remove and install the tires. Using a tire lever to remove and install the tires can damage to the tire, the wheel, and the TPMS sensor.
 - The wheel nut torque is 108 N·m (80 lb-ft).
 - Be careful not to damage the wheel center cap when installing the emblems.
 - This center cap emblem should be installed only if the ambient air temperature is 60°F (15°C) or above.
 - To allow the adhesive to “cure,” do not wash the vehicle for 24 hours.
1. Remove the tire-and-wheel assembly from the vehicle according to the Service Manual.
 2. Remove the tire from the wheel according to the Service Manual. (The tire will be reused.)

3. Remove the tire pressure sensor from the wheel.

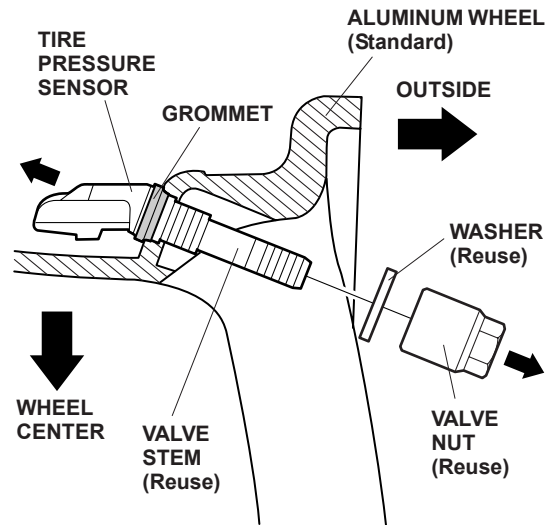

4. Replace the grommet of the tire pressure sensor that you just removed with a new one.

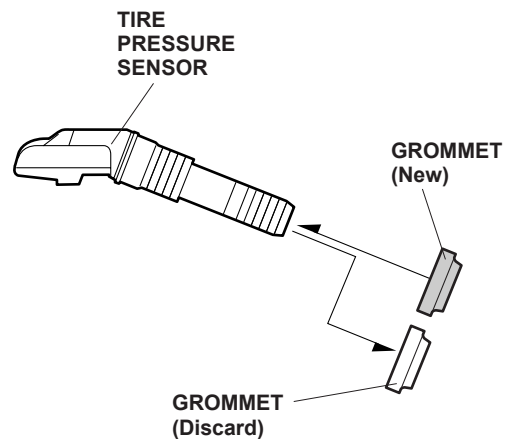

5. Install the tire pressure sensor to the aluminum wheel and loosely install the valve nut. Make sure the pressure sensor is resting on the wheel.

NOTE:

Before installing the tire pressure sensor, clean the mating surface and the valve hole of the aluminum wheel.

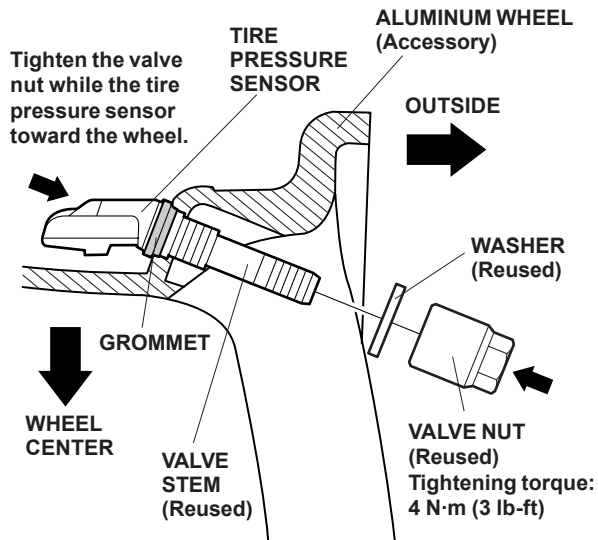

6. Tighten the valve nut to the specified torque while holding the tire pressure sensor toward the wheel. Tightening torque: 4 N·m (3 lb-ft).

NOTE:

- Do not reuse the grommet that had been tightened, even one time, to the specified torque, as they are deformed inside.
 - Do not use pneumatic or electric tools on the valve nut.
 - Tightening the nut to the specified torque or above can damage the grommet.
 - Make sure that there is no space between the sensor and the wheel.
7. Assemble the tire with the wheel according to the Service Manual.
 8. Install the tire-and-wheel assembly on the vehicle according to the Service Manual.
 9. Memorize the ID of tire pressure sensor according to the instructions in the Service Manual.
 10. Using isopropyl alcohol on a shop towel, clean the

area where the center cap emblem will attach.

11. Remove the adhesive backing from the center cap emblem.

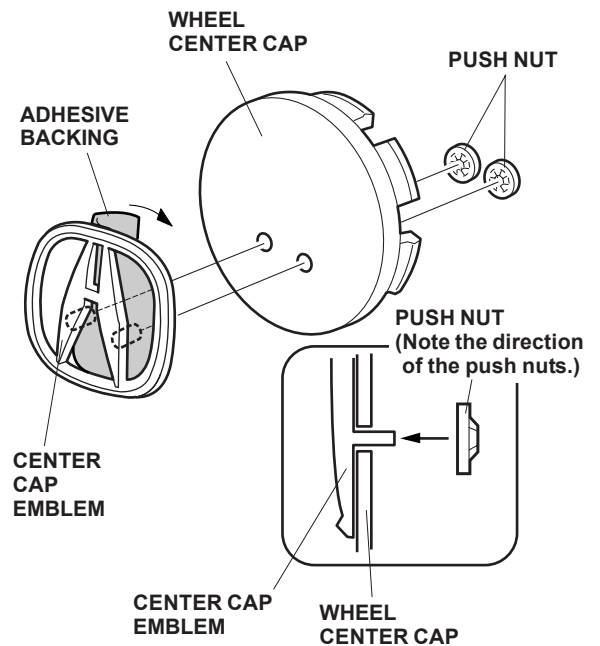

12. Attach the center cap emblem to the wheel center cap by aligning its pins with the holes in the wheel center cap. After attaching, hold the emblem firmly against the wheel center cap with the palm of your hand for 30 seconds.
13. Slide the push nuts onto the pins. Note the direction of the push nuts.
14. Install the wheel center cap assembled with the emblem on the wheel.

15. Be sure to give the wheel cleaning information to your customer.

