



INSTALLATION INSTRUCTIONS

Accessory
SKI ATTACHMENT
 P/N 08L03-TA1-200A

Application
2007 RDX

Publications No.
BII 33267
 Issue Date
AUG 2006

Put this information in the glove box with the vehicle owner's manual.

PARTS LIST

2 Ski attachments

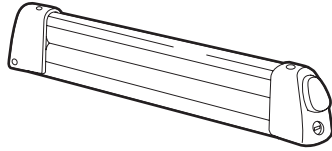

4 Knobs



4 T-bolts

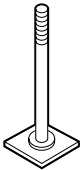

4 Spacers

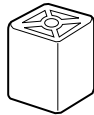

2 Keys



TOOLS REQUIRED

- Flat-tip screwdriver
- T30 Torx bit
- Ratchet

INSTALLATION

NOTE:

- The ski attachments are designed to be used exclusively with an Acura roof rack, which is sold separately. If the vehicle is not equipped with a roof rack, install a roof rack before installing the ski attachments.
- The ski attachments may be installed either with both on the driver's side or with both on the passenger's side.

- Using a flat-tip screwdriver, push in on the locking tab and remove the roof rack cover. Remove the roof rack cover from the other roof rack the same way.

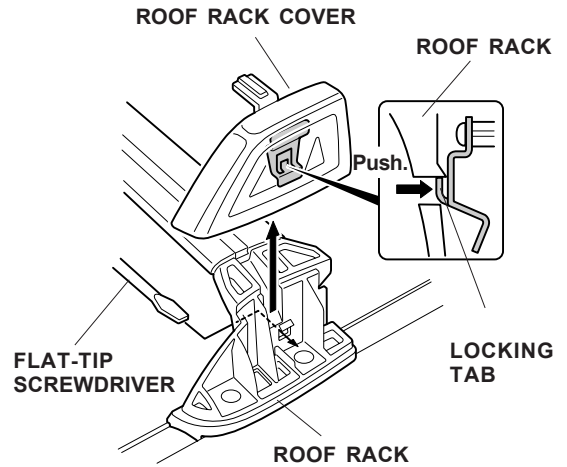

- Remove the rubber moldings from the front and rear roof rack crossbars. Retain the rubber moldings to be reinstalled if the ski attachments are removed.

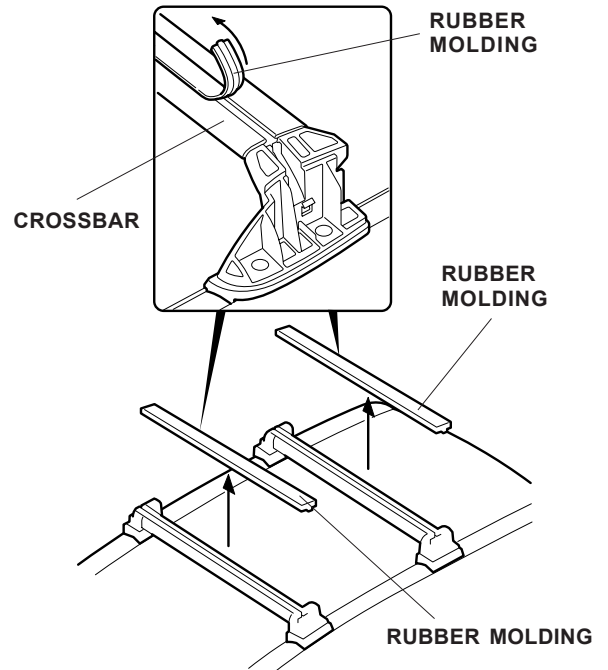

- Slide two T-bolts into each crossbar.

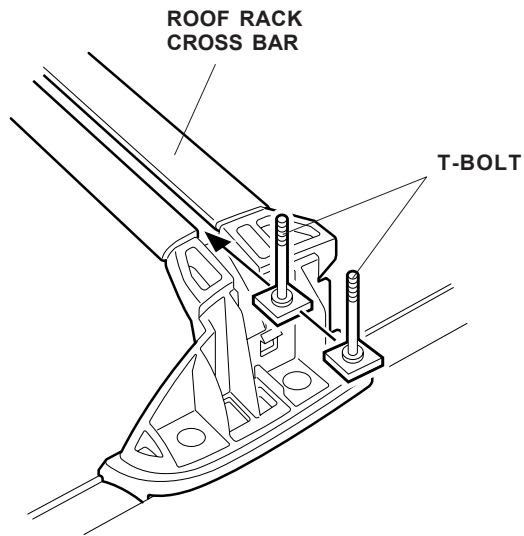

- Reinstall the roof rack covers.
- Insert the key, and turn it clockwise to unlock the front ski attachment. Press the button and open the top frame completely.

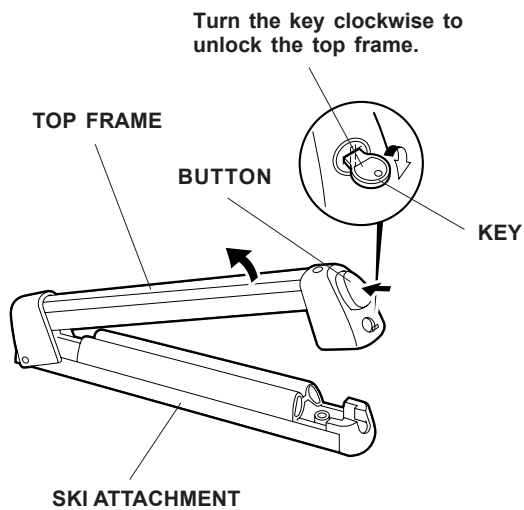

- Position the spacers and the front ski attachment onto the T-bolts, and install the two knobs. Tighten the knobs securely.

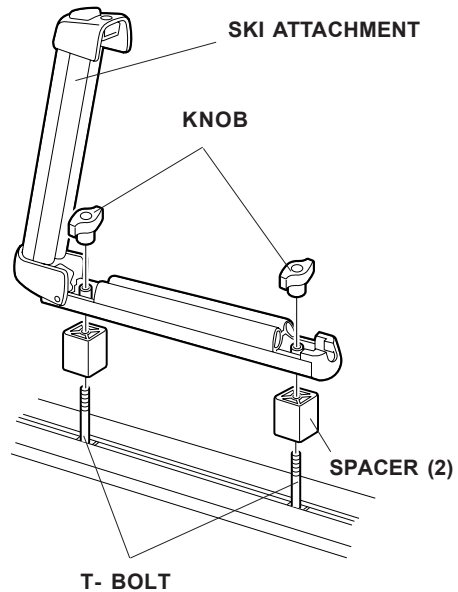

- Repeat steps 5 and 6 to install a ski attachment to the rear crossbar.
- Close the top frame and listen for it to click into position, then turn the key counterclockwise to lock the top frame.
- Rock the ski attachment in all directions to make sure it is installed securely. If necessary, retighten the T-bolts or reinstall the ski attachment.
- Tell the customer to write down the key number, and put the number in a safe place in case the key is lost or stolen.
- To prevent excess wind noise, cut each rubber molding, and install the cut pieces into the grooves in the crossbars.

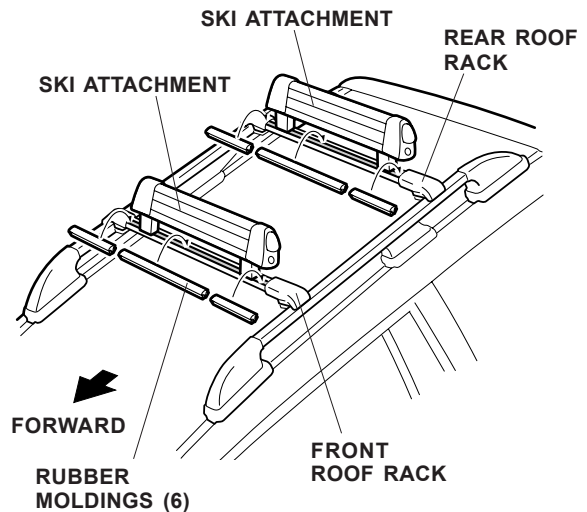

Loading Skis on the Attachment

1. Insert the key, and turn it clockwise to unlock the top frame. Push the button and raise the top frame completely.

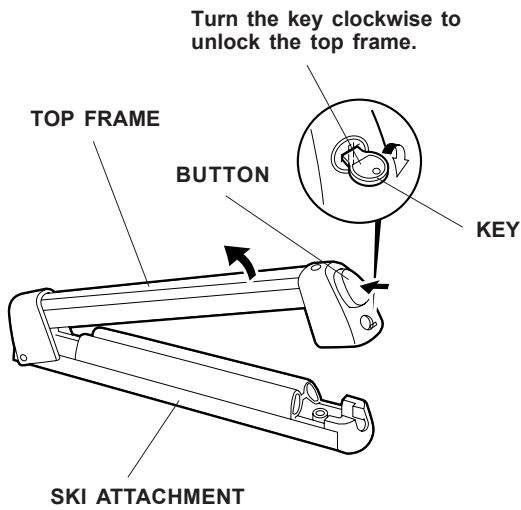

2. Position the skis on the attachment in these ways:
 - Load with the rear of the skis facing forward, and the bindings between the front and rear

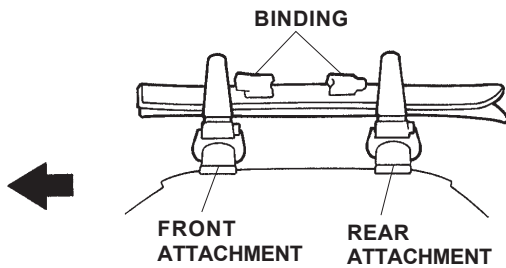

attachments.

- If the bindings cannot be positioned between the front and rear attachments, install the skis with one of the bindings positioned behind the rear attachment.

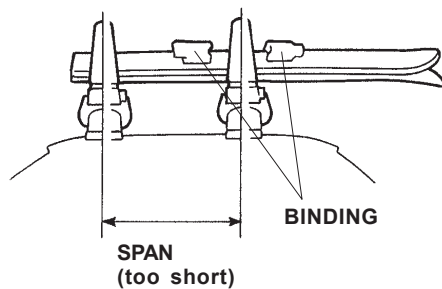

3. Close the top frame and listen for it to click into position. Depending on the thickness of the ski, you may need to attach the hook in the second position.

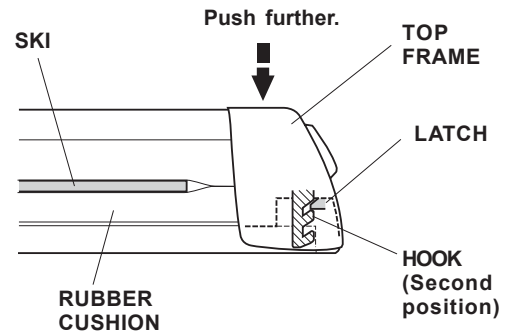
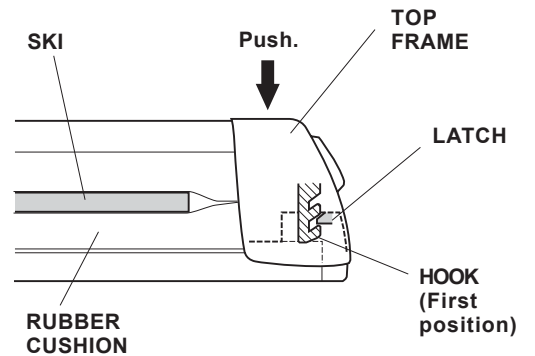

4. Lock the top frame by turning the key counterclockwise. Remove the key.

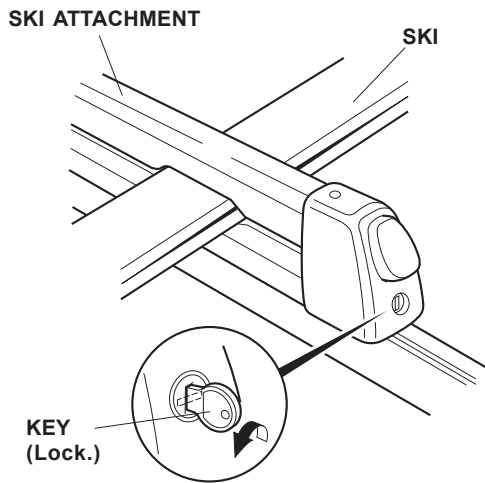

5. With the ski attached, rock the attachment in all directions to make sure it is installed securely. Adjust as necessary.

