



# INSTALLATION INSTRUCTIONS

Accessory  
**BICYCLE ATTACHMENT  
(HITCH MOUNT)**  
P/N 08L14-TA1-200

Application  
**2007 MDX**

Publications No.  
**BII 33389**  
Issue Date  
**OCT 2006**

Put this information in the glove box with the vehicle owner's manual.

## PARTS LIST

Upright assembly

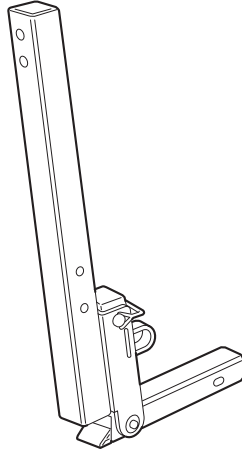

Bicycle arm bracket

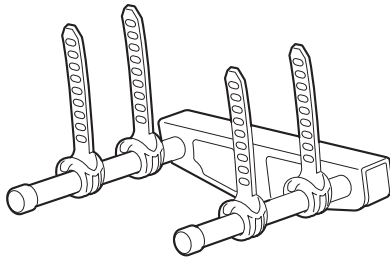

Bolt, 12 x 40 mm



4 Bolts, 8 x 70 mm



4 Washers, 8 mm



Flat washer, 12 mm



Lock washer, 12 mm



4 Nuts



4 Nut covers



Tie-down bar

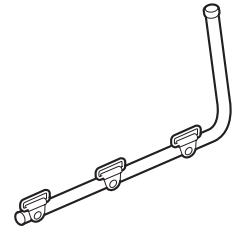

2 Clamps



2 Spacers



2 Socket bolts, 6 x 55 mm

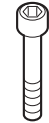

Hex wrench

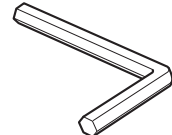

4 Straps



## TOOLS REQUIRED

Ratchet

13 mm and 19 mm sockets

## INSTALLATION

### NOTE

- Be careful not to damage the finished surfaces of the body when installing the bicycle carrier.
  - No more than 2 bicycles should be loaded on the bicycle carrier.
1. Slide the upright assembly into the trailer hitch receiver until the hole in the tube lines up with the receiver hole. Install the 12 x 40 mm bolt with lock washer and flat washer through the receiver hole. Tighten the 12 x 40 mm bolt securely.

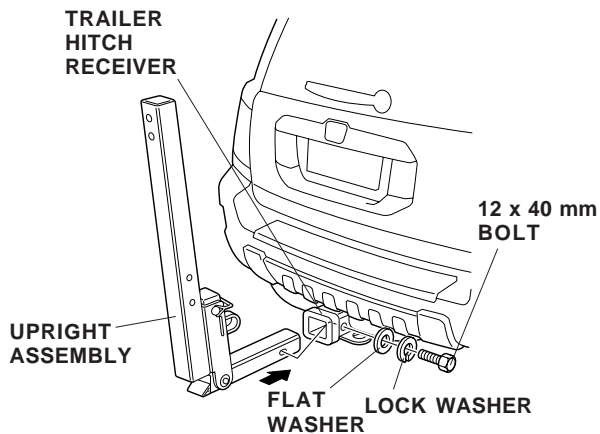

2. Lower the bicycle arm bracket onto the upright assembly as shown.

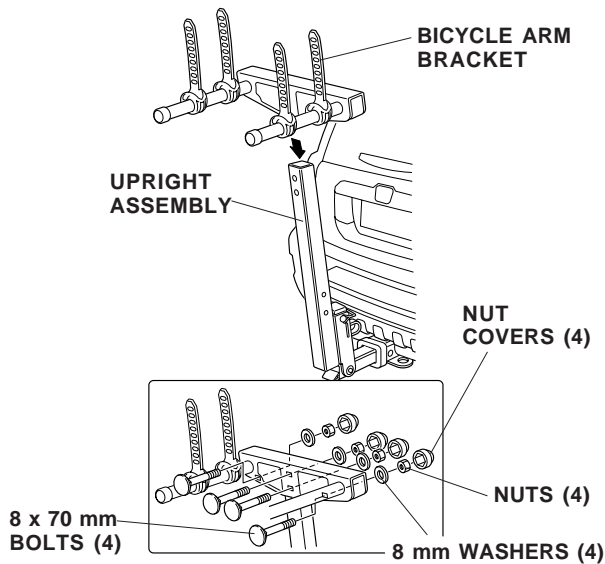

3. Assemble the 8 x 70 mm bolts, 8 mm washers, and nuts as shown. Tighten all 4 bolts securely.
4. Install four nut covers.

5. Align the tie-down bar and two clamps with the upright assembly, then secure with the two socket bolts and two spacers.

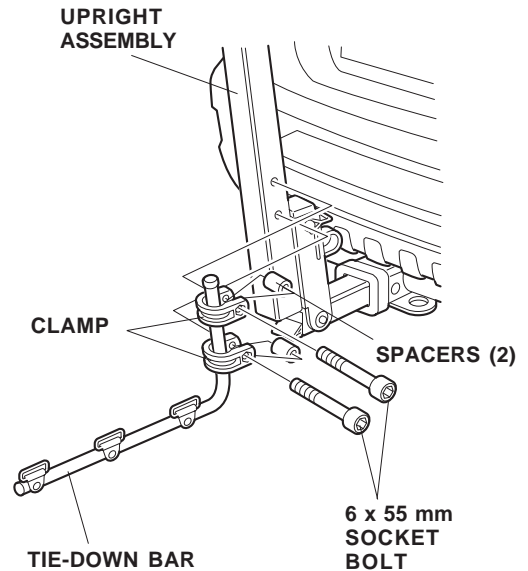

6. Turn the tie-down bar 90° in the direction shown. This is the stored position.

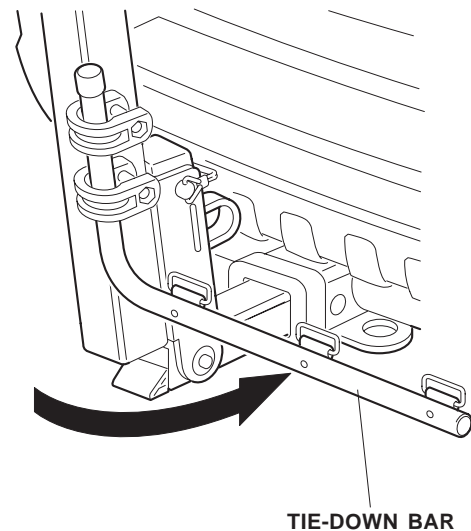

## Loading the Bicycles

1. Load the heaviest bicycle first onto the inner most cradle. The cradles can be rotated or shifted on the bars to accommodate different bicycle frame types.

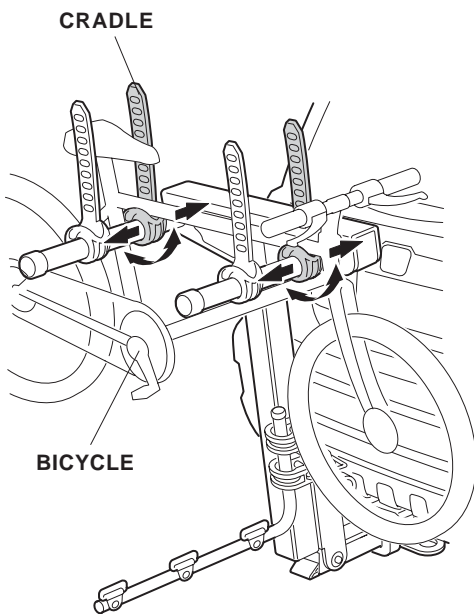
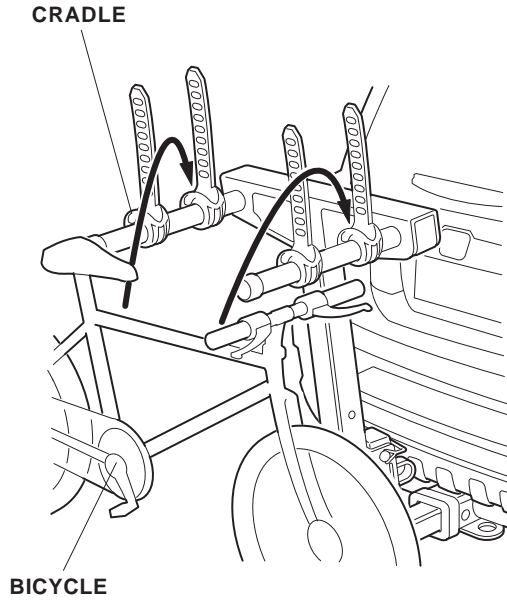

2. When loading two bicycles, alternate the direction of the bicycles.

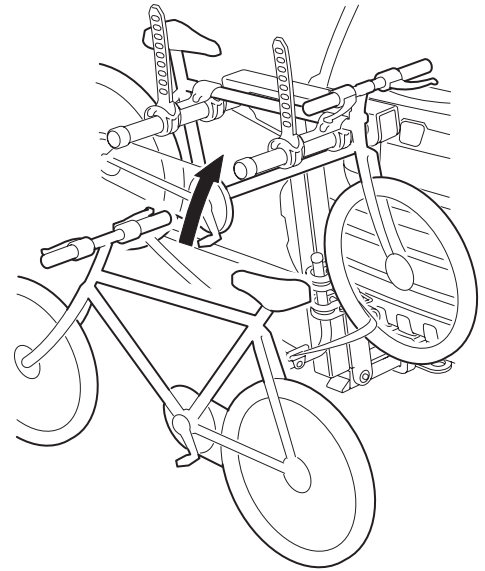

3. Tighten the bicycle arm straps securely around the bicycle frame.

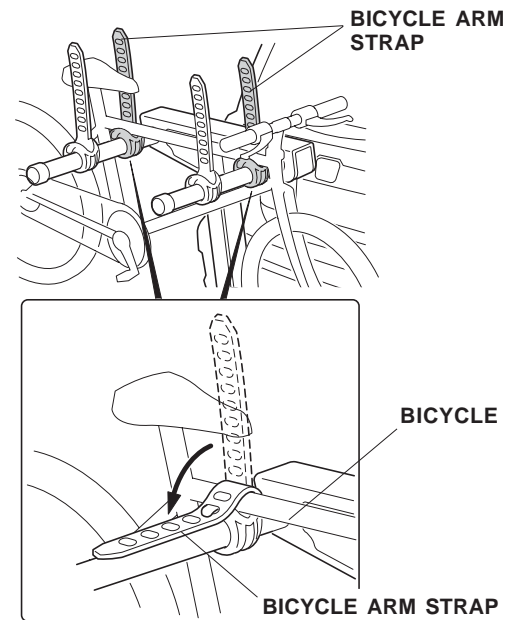

4. Using the straps provided, secure the bicycles to the tie-down bar (either through the bicycle wheels or the frame).
  - Secure the inner bicycle to the **A** position on the tie-down bar.
  - Secure the second bicycle to the **B** or **C** position on the tie-down bar.
  - Secure the strap buckle as shown.

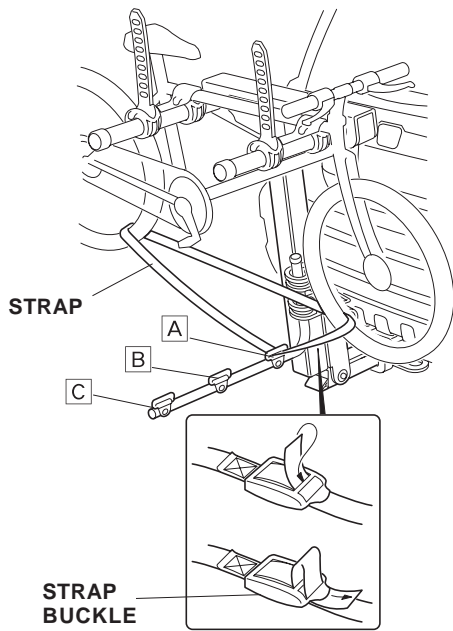

### Opening the tailgate

1. All bicycles must be removed to lower the carrier. Rotate the tie-down bar 90° then firmly hold the upright assembly with one hand. Release the safety hook by pulling outward on the untethered end. Slide the pin out while supporting the upright assembly.

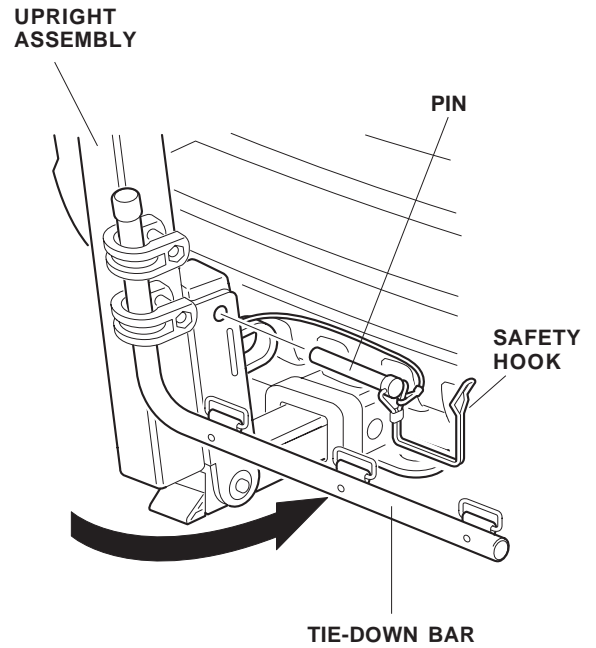

2. Gently lower the bicycle carrier.

