

ACURA INSTALLATION INSTRUCTIONS

Accessory
**ENGINE BLOCK HEATER
P/N 08T44-SEC-201**

Application
2006 TSX

Publications No.
BII 31327
Issue Date
OCT 2005

PARTS LIST

Engine block heater

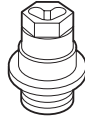

Aluminum washer



Heater harness

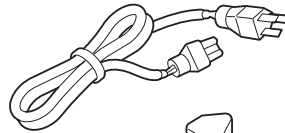

Protective cap

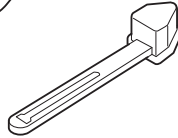

15 Wire ties
(3 Not used)

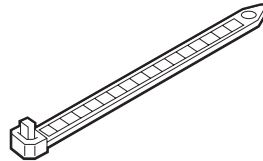

Flange-bolt



O-ring



Cap

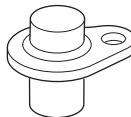

TOOLS AND SUPPLIES REQUIRED

Clip remover
Phillips screwdriver
Ratchet
10 mm and 24 mm Socket
Torque wrench
Diagonal cutters
Coolant (Honda All Season Antifreeze/Coolant Type 2)
8 mm or 10 mm Allen socket
White marker
Tape measure

NOTE

- Always use Honda All Season Antifreeze/Coolant Type 2. Using a non-Honda coolant can result in corrosion, causing the cooling system to malfunction or fail.
- To avoid burning out the element, do not operate the engine block heater before it is installed in the vehicle and before you add coolant.

INSTALLATION

Customer Information: The information in this installation instruction is intended for use only by skilled technicians who have the proper tools, equipment, and training to correctly and safely add equipment to your vehicle. These procedures should not be attempted by "do-it-yourselfers."

1. Allow the engine and all cooling system components to cool down.
2. Place a clean drain pan under the radiator drain plug, then remove the drain plug from the bottom of the radiator to drain the coolant. Remove the radiator cap to increase the flow.

NOTE: Radiator coolant will damage paint. Quickly rinse any spilled coolant from painted surfaces.

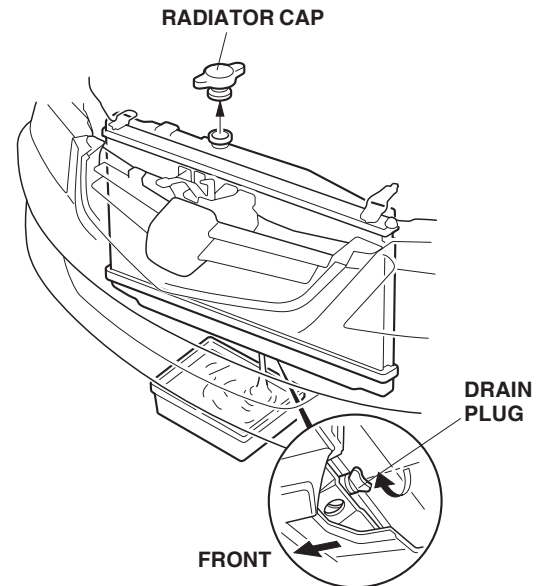

- Remove the radiator cover (12 clips).

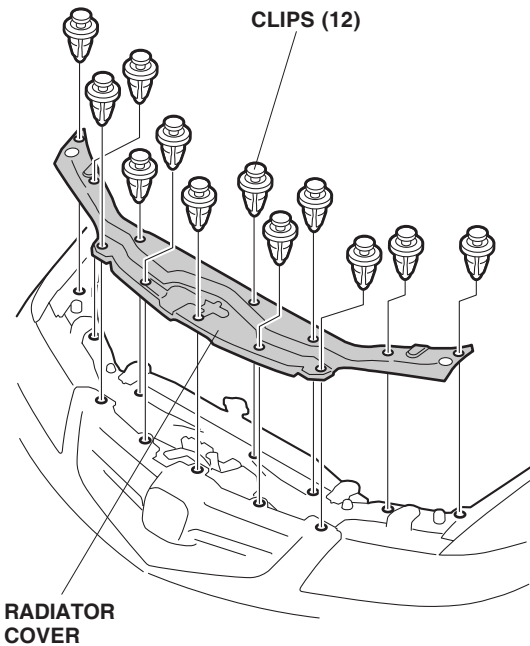

- Remove the air duct cover (three clips).

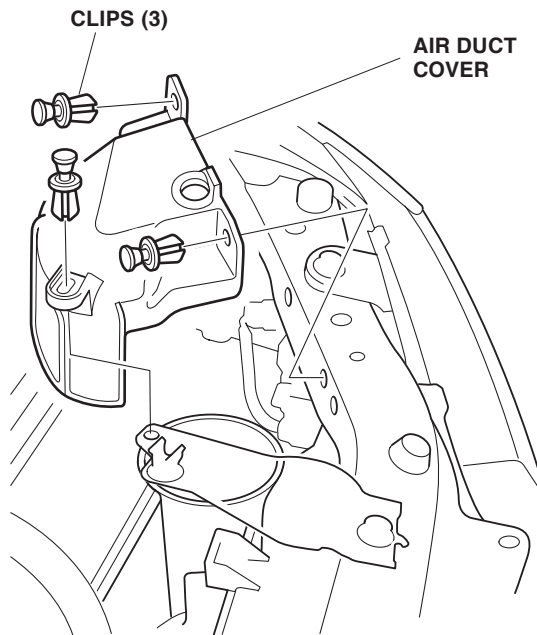

- Remove the drain plug from the back side of the engine block. Coolant remaining in the engine jackets will flow out of the hole when the plug is removed. Retain the plug, so it can be used if the engine block heater is removed.

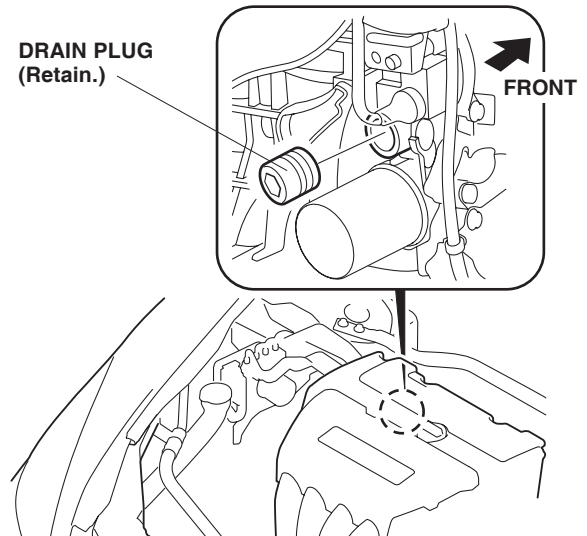

- Install the engine block heater with the aluminum washer into the hole using a 24 mm socket. Torque the engine block heater to 60 N·m (44 lb-ft).

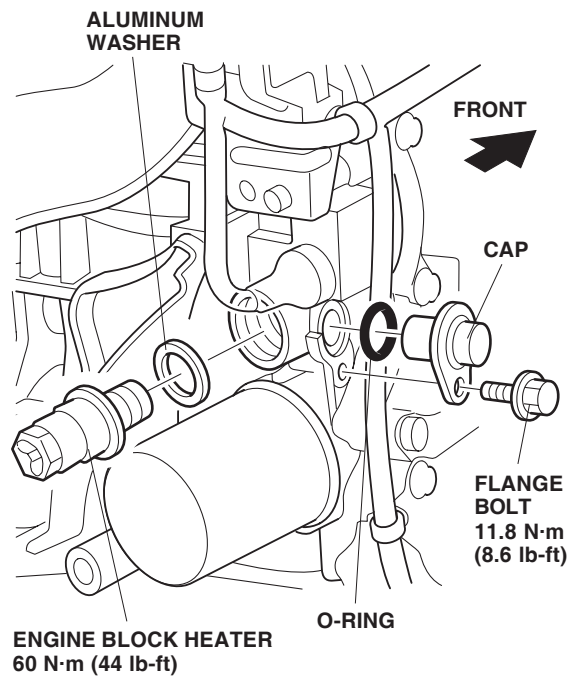

- Insert the O-ring onto the cap, and install the cap into the hole of the engine with the flange bolt. Torque the flange bolt to 11.8 N·m (8.6 lb-ft).

- Using a white marker and tape measure, mark the heater harness at the measurements shown.

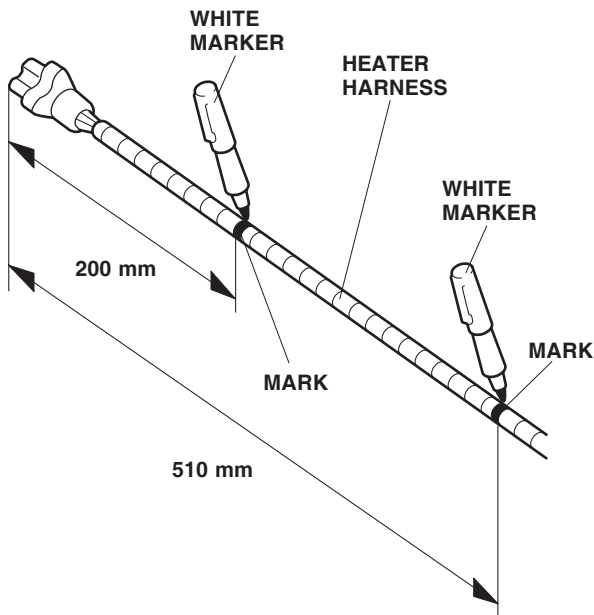

- Plug the heater harness connector into the engine block heater. Route the heater harness alongside the vehicle harness, and secure it to the vehicle harness with one wire tie at the white mark.

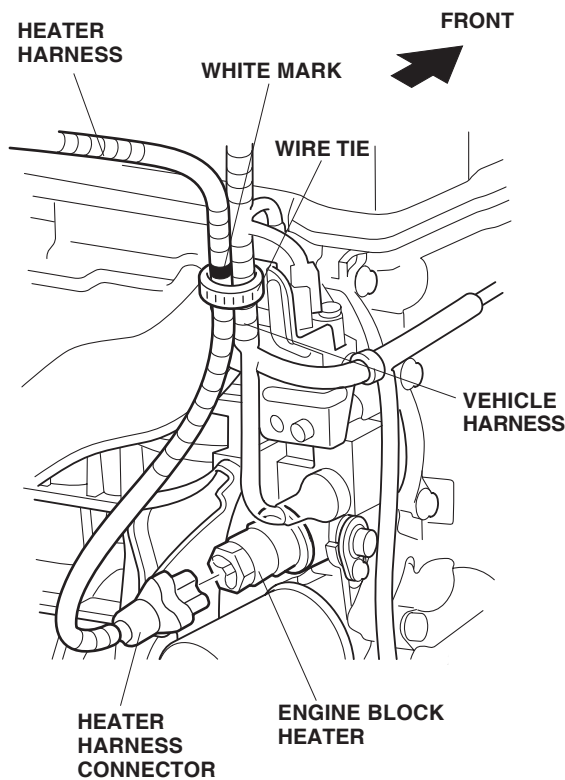

- Route the heater harness alongside the vehicle harness, and secure the heater harness to the vehicle harness and frame with four wire ties.

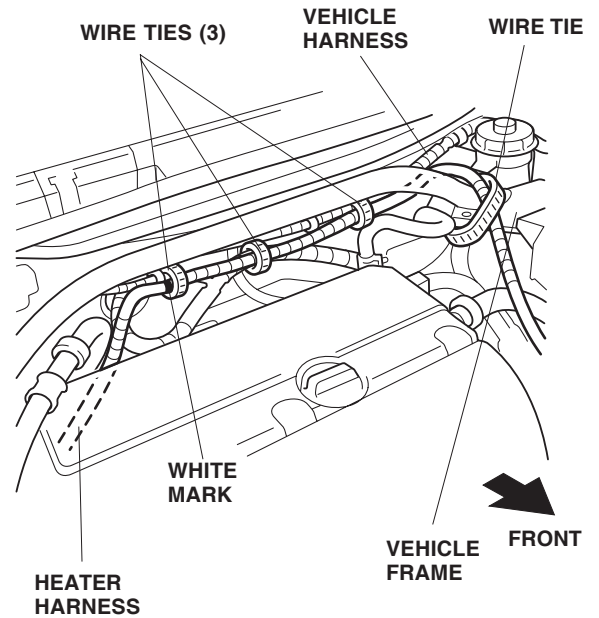

- Continue routing the heater harness alongside the vehicle harness, and secure the heater harness to the vehicle harness with three wire ties.

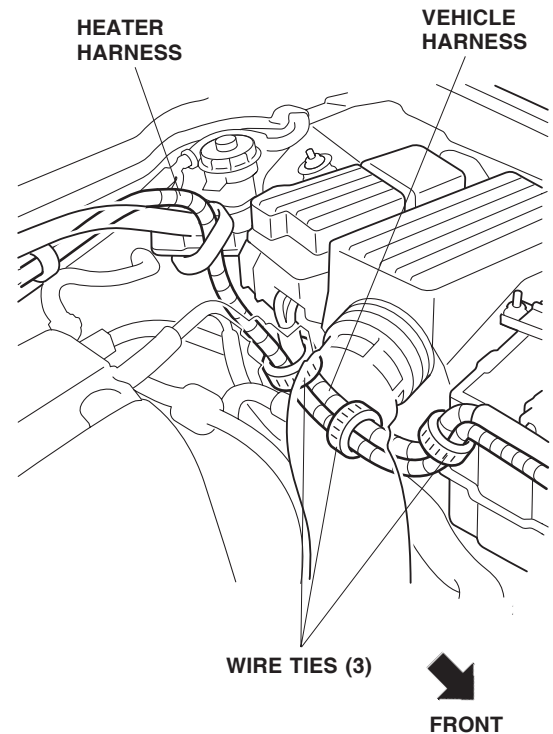

- Continue routing the heater harness along the vehicle harness through the front bulkhead to the right side of the radiator. Secure the heater harness to the vehicle harness with one wire tie positioned on the inside of the front bulkhead.

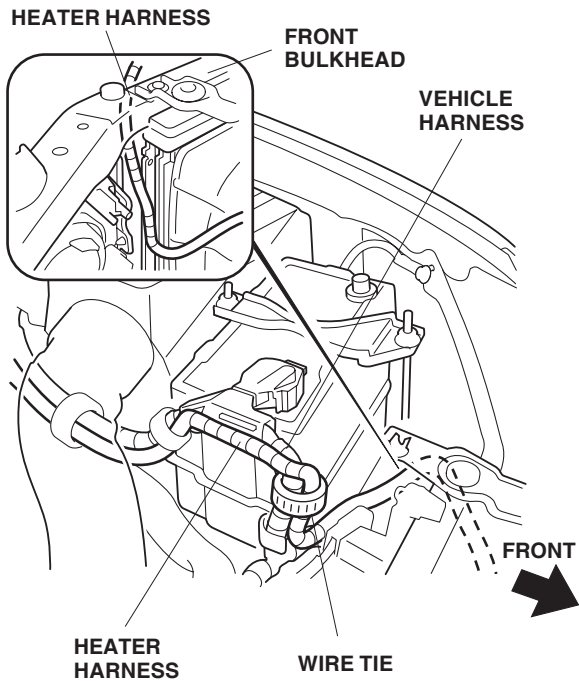

- Continue routing the heater harness along the vehicle harness through the front bulkhead to the center of the bumper grille. Secure the heater harness to the vehicle harness and bumper beam with two wire ties.

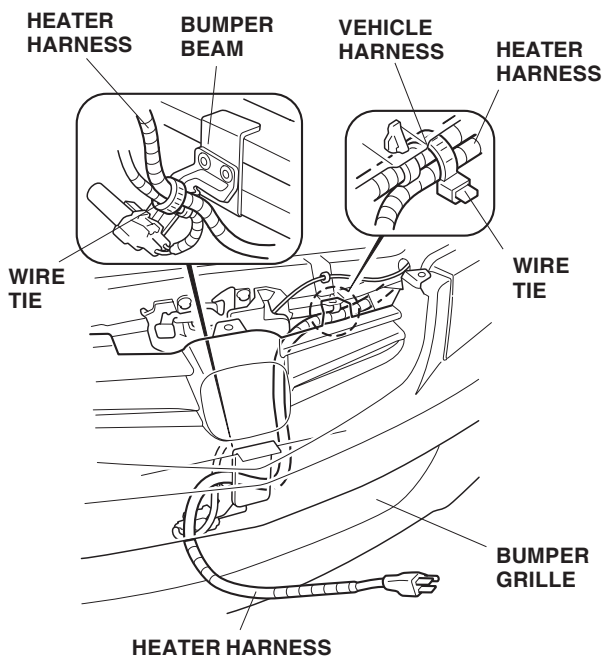

- Secure the heater harness to the bumper grille with one wire tie.

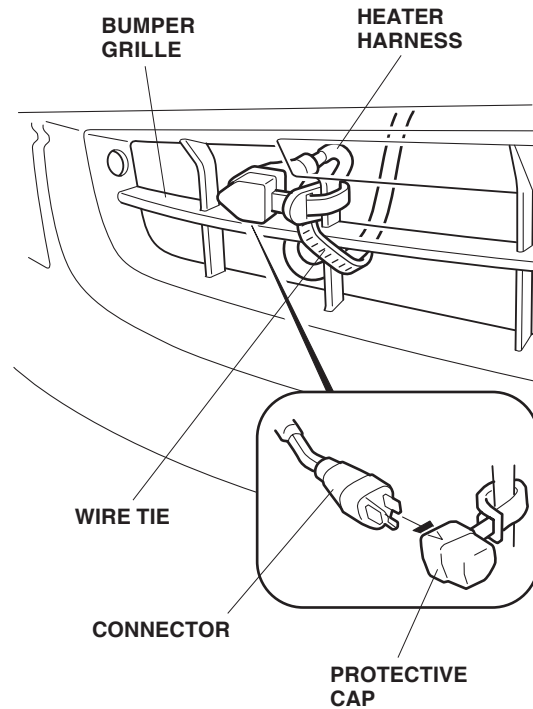

- Attach the protective cap to the grille, and plug the heater harness connector into the protective cap.
- Reinstall the radiator drain plug.
- Fill the system with the recommended coolant. Follow the instructions described in the service manual to fill and bleed the cooling system.
- Check the coolant reservoir for correct level and check the cooling system for signs of leakage. Repair if necessary.
- Check that the heater harness is routed properly and all connectors are plugged in.
- Reinstall all removed parts.
- Give the drain plug (removed in step 5) to your customer.