



INSTALLATION INSTRUCTIONS

Accessory

TAILGATE DEFLECTOR
P/N 08F40-S3V-200

Application

2006 MDX

Publications No.

BII 30982

Issue Date

SEP 2005

PARTS LIST

Tailgate deflector

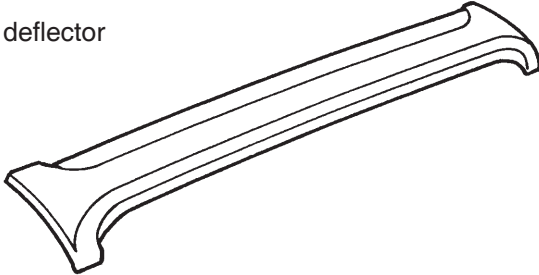

4 Square-head bolts



4 Cap nuts



6 Foam adhesive washers
(2 Not used)



TOOLS AND SUPPLIES REQUIRED

Ratchet

10 mm Socket

Eye protection (face shield, safety goggles, etc.)

Drill

3 mm and 8 mm Drill bits

File

Touch-up paint

Center punch

Torque wrench

INSTALLATION

NOTE: Be careful not to damage the tailgate or other finished body surfaces when installing the tailgate deflector.

1. Open the tailgate.
2. Locate the two identification marks on the tailgate. Mark and lightly center-punch the center of each mark. Repeat on the other side.

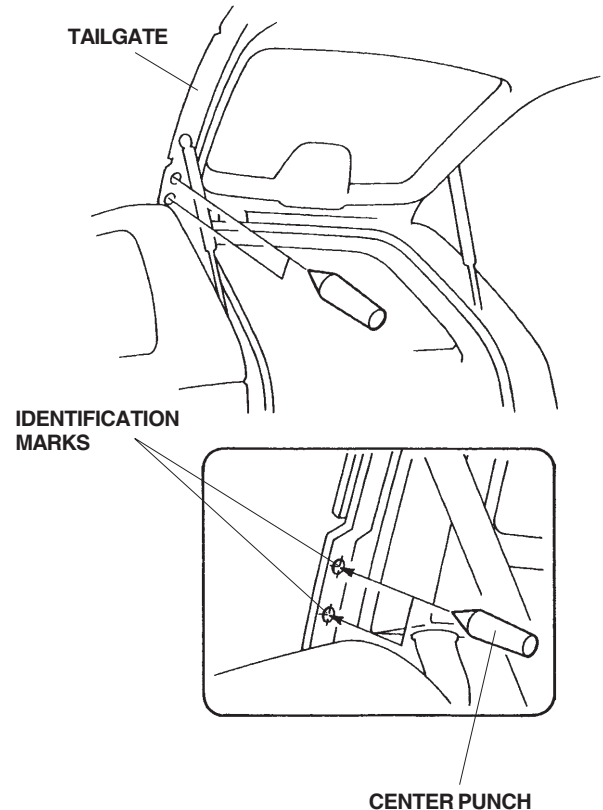

3. While wearing eye protection, drill an 8 mm hole through each mark.
 - First drill with a 3 mm bit, and finish with an 8 mm bit.
 - Remove all burrs and metal shavings, and apply touch-up paint to the edges of the holes.
 - Repeat on the other side.
 - When the touch-up paint is dry, clean the area to be covered, and wax it with a high-quality paste wax.

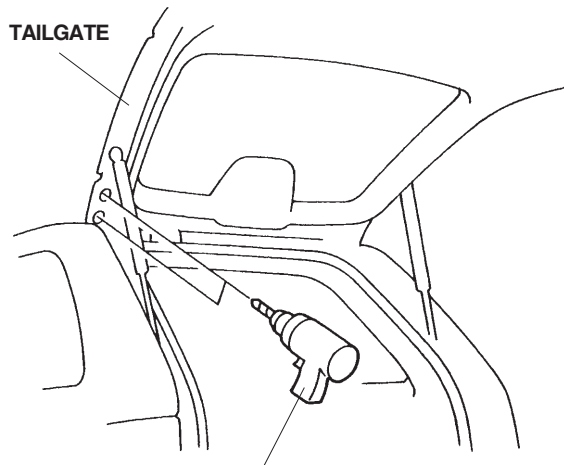

First drill pilot holes with a 3 mm bit, and finish with an 8 mm bit.

4. Remove the adhesive backing from four foam adhesive washers, and attach them to the tailgate over the holes you just drilled.

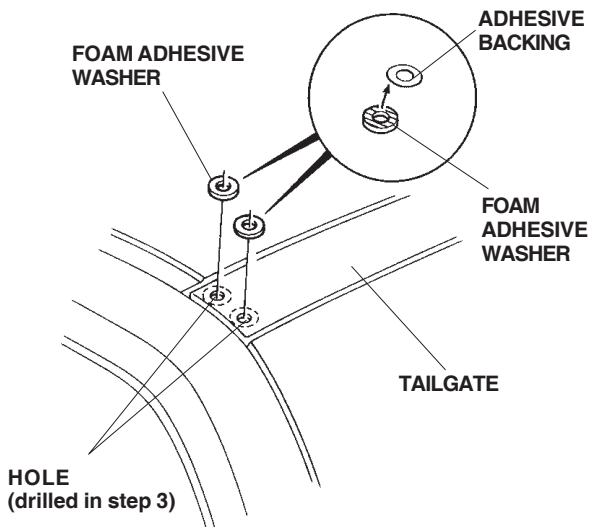

5. Install the four square-head bolts on the back of the tailgate deflector.

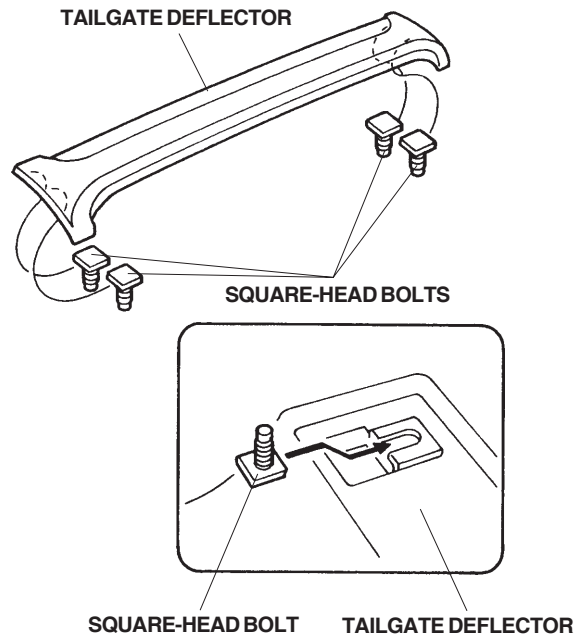

6. Insert the bolts through the four holes you made in step 3. Adjust the deflector so that it is positioned evenly on both sides of the tailgate.

Position the deflector evenly on both sides.

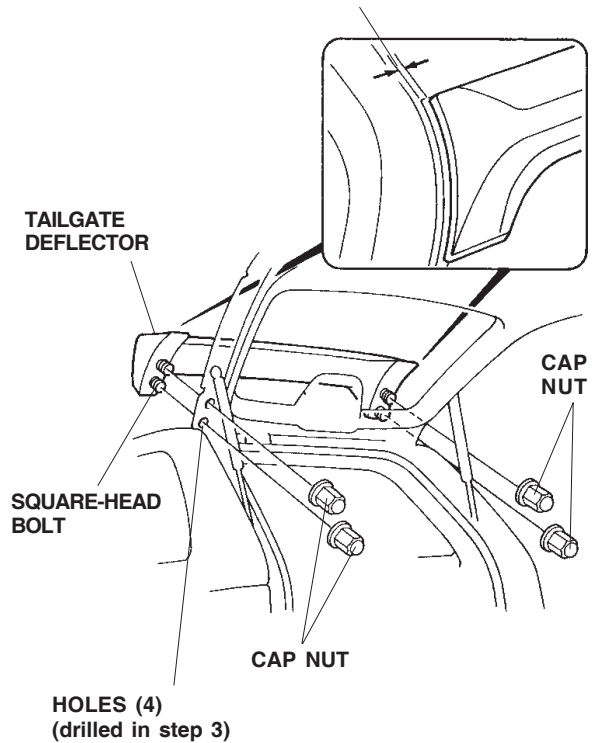

7. Install a cap nut onto the end of each bolt, and torque the cap nuts to 7 to 10 N•m (5 to 7 lb-ft).