



INSTALLATION INSTRUCTIONS

Accessory

GOLD GRILLE MOLDING
P/N 08F21-S3V-200A

Application

2006 MDX

Publications No.

BII 30970

Issue Date

SEP 2005

PARTS LIST

Gold grille molding

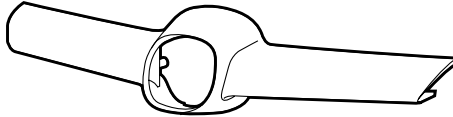

TOOLS AND SUPPLIES REQUIRED

Phillips screwdriver

Ratchet

10 mm Socket

Blanket

INSTALLATION

NOTE:

- Be careful not to damage the body finish when removing and installing the molding.
- To prevent damage to the front bumper rest the front bumper on a blanket during the installation.
- If you're installing the gold emblem kit (sold separately), install the front gold "A" emblem before installing the gold grille molding.

1. Remove the two self-tapping screws, seven clips and four bolts that secure the front bumper. If the vehicle is equipped with optional fender flares, remove the top inner fender screws that secure the bumper.

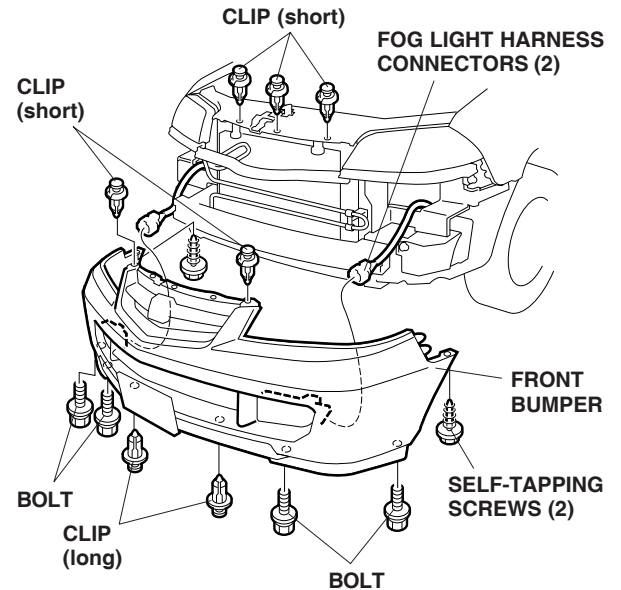

2. Pull the front bumper out toward you, then disconnect the fog light harness connectors. Remove the front bumper and rest it on a blanket.
3. Remove the six self-tapping screws that fasten the front grille molding to the front bumper, and remove the front grille molding.

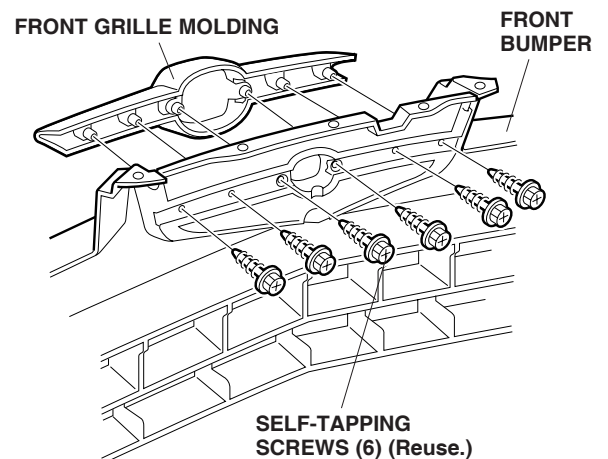

- Remove the two self-tapping screws that fasten the "A" emblem and the emblem base to the front grille molding; remove the front grille molding.

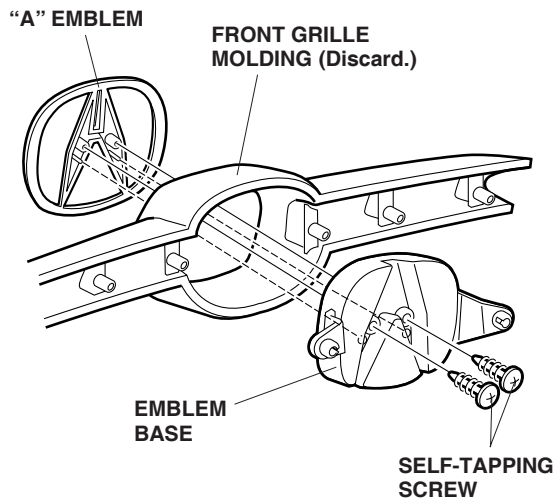

- Position the "A" emblem on the gold grille molding and emblem base. Align the pins on the emblem with the holes in the emblem base. Install the two self-tapping screws onto the pins.

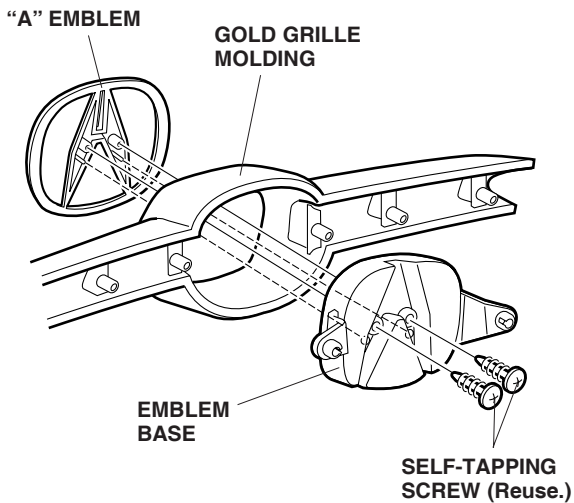

- Position the gold grille molding on the front bumper, and install the six self-tapping screws.

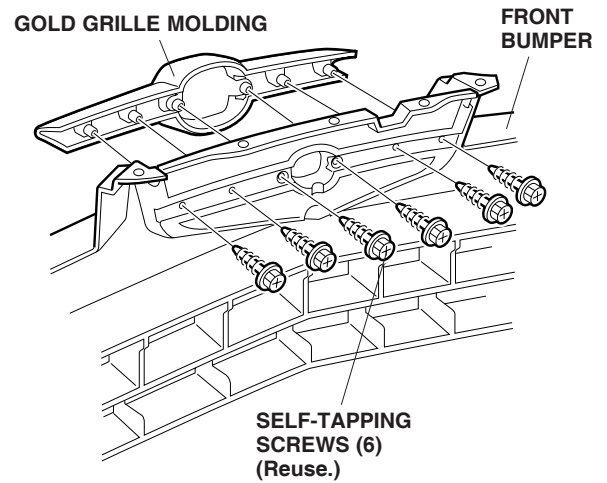

- Reinstall the front bumper. Check that all clips are installed securely.