



# INSTALLATION INSTRUCTIONS

Accessory

**SPLASH GUARD**  
P/N 08P00-SEC-200

Application

2005 TSX

Publications No.

**BII 28370**

Issue Date

**OCT 2004**

**NOTE:** Splash guards *cannot* be installed on a vehicle equipped with the under spoiler kit.

## PARTS LIST

Left front splash guard

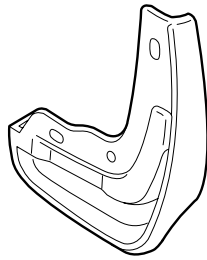

Right front splash guard

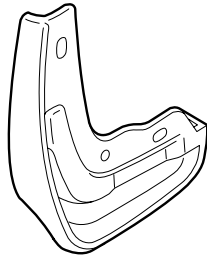

Left rear splash guard

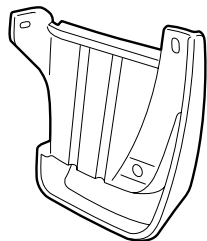

Right rear splash guard

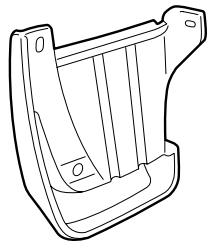

8 Self-tapping screws

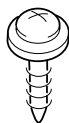

2 Spring nuts



## TOOLS AND SUPPLIES REQUIRED

Phillips screwdriver

Stubby Phillips screwdriver

Pushpin

## INSTALLATION

**NOTE:** These instructions show the left side splash guards being installed. The same procedure applies to installing the right side splash guards.

### Installing the Front Splash Guards

1. Turn the steering wheel all the way counterclockwise.
2. Remove and retain the two self-tapping screws that fasten the left front inner fender to the front fender and fenderwell.
3. Using the pushpin, pierce a hole through the center of the inner fenderwell retaining clip, as shown.

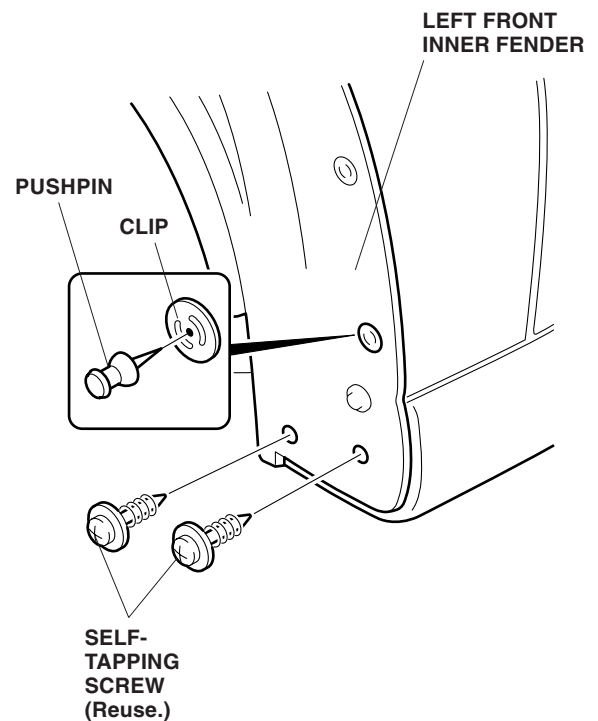

4. Position the left front splash guard on the left front inner fender and loosely install the two self-tapping screws removed in step 2, and one self-tapping screw from the kit. Align the recess on the splash guard with the projection on the bottom of the body as shown.
5. Tighten the three self-tapping screws installed in step 4 in the order of **A**, **B**, and **C**. After tightening, check that there is no clearance between the splash guard and body.

**NOTE:** If there is any clearance between the splash guard and body, loosen the three self-tapping screws that fasten the splash guard to the inner fender and fenderwell and one self-tapping screw that fastens the inner fender to the fenderwell, relocate the splash guard on the inner fender, then retighten the self-tapping screws.

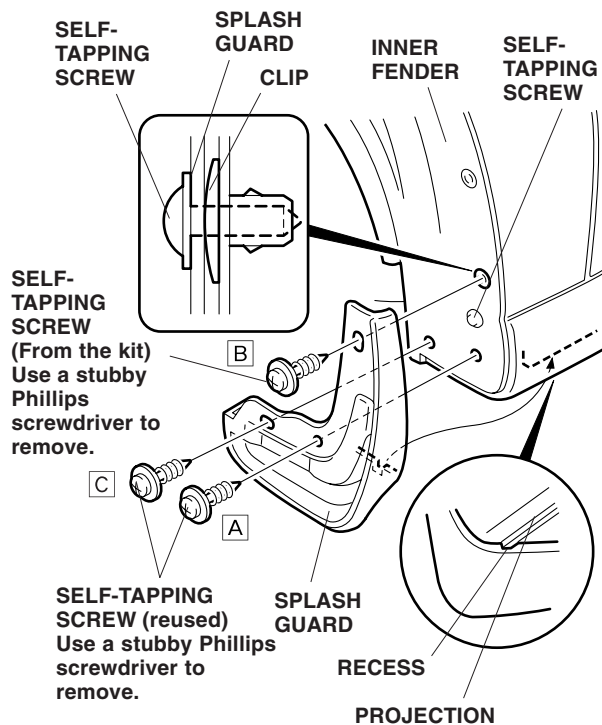

6. Turn the steering wheel all the way clockwise, and repeat step 2 thru 5 to install the right front splash guard.

## Installing the Rear Splash Guards

7. Remove the self-tapping screw from the rear bumper.
8. Slide one spring nut over the dimpled area of the rear bumper. If the clip nut is loose, squeeze the ends together so that it fits snugly onto the rear bumper.
9. Using the pushpin, pierce a hole through the center of the inner fenderwell retaining clip, as shown.
10. Using the pushpin, pierce a hole through the dimpled spot in the rear bumper.

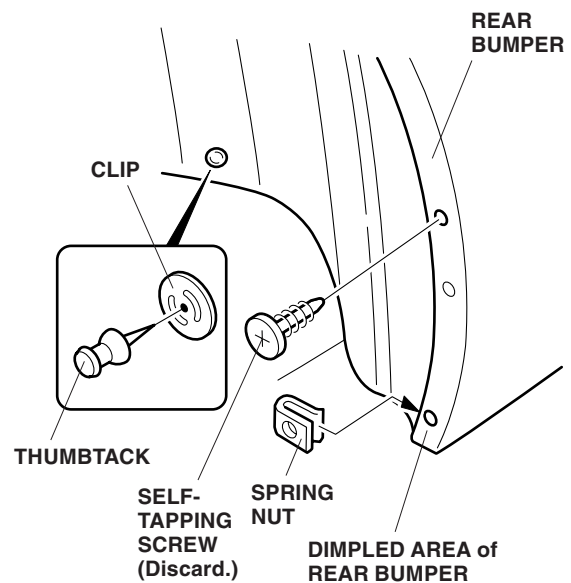

11. Position the left rear splash guard on the rear bumper, and install three self-tapping screws from the kit. Align the recess on the back of the splash guard with the projection on the bottom of the body as shown.
12. Tighten the self-tapping screws in the order of **A**, **B**, and **C**. After tightening, check that there is no clearance between the splash guard and body.

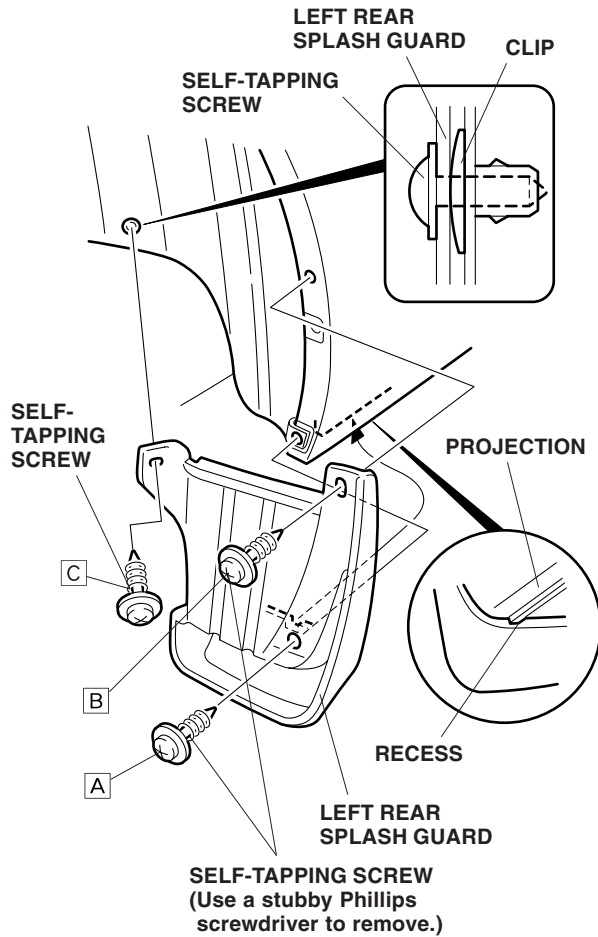

13. Repeat steps 7 thru 12 to install the right rear splash guard.