



INSTALLATION INSTRUCTIONS

Accessory

ASHTRAY
P/N 08U25-SJA-200

Application

2005 RL

Publications No.

BII 27023

Issue Date

SEP 2004

PARTS LIST

Ashtray

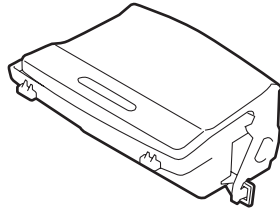

Inner case

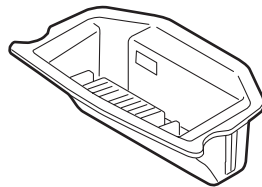

TOOLS REQUIRED

Phillips screwdriver

INSTALLATION

Customer Information: The information in this installation instruction is intended for use only by skilled technicians who have the proper tools, equipment, and training to correctly and safely add equipment to your car. These procedures should not be attempted by "do-it-yourselfers."

1. Make sure you have the anti-theft codes for the radio and navigation system, then write down the radio presets.
2. Disconnect the negative cable from the battery.

3. With the parking brake applied, place the gear shift lever in the neutral position.

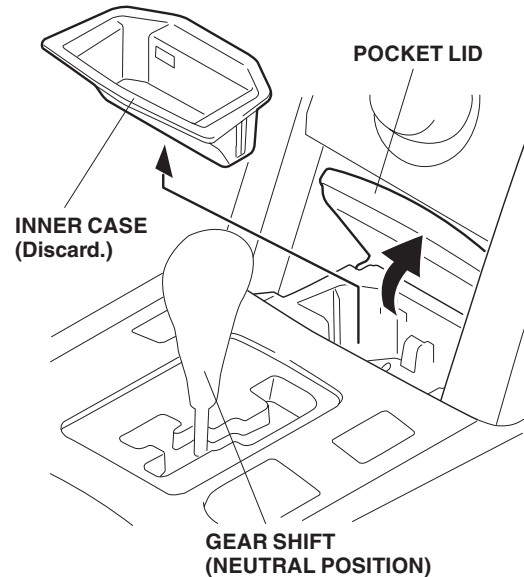

4. Open the pocket lid, and remove the inner case.
5. Remove the center console trim (four clips, clip that secures the vehicle's harnesses and disconnect the vehicle's connectors). The number of the vehicle's connectors varies depending on type of the vehicle.

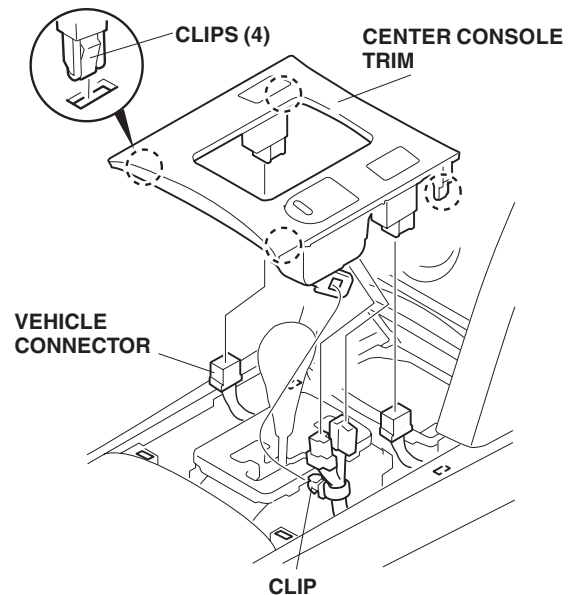

- Remove the two self-tapping screws from the pocket.

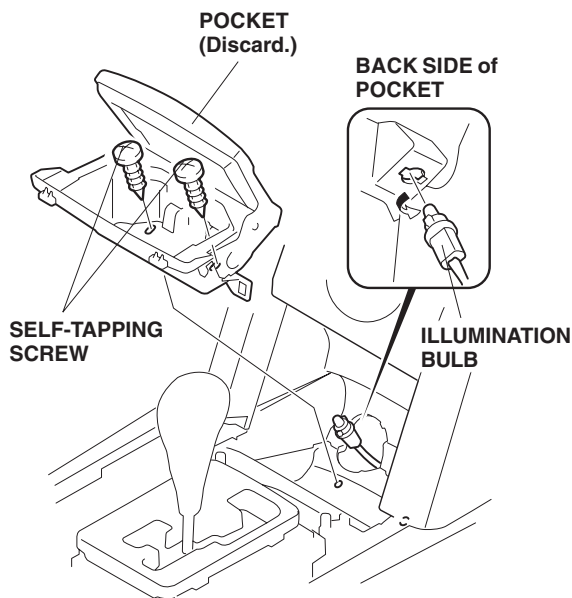

- Pry out on the pocket, then remove the illumination bulb by twisting from the rear of the pocket. The illumination harness is short. Take care not to pull it excessively. Remove the pocket.
- Install the illumination bulb to the ashtray, and install the ashtray with the two self-tapping screws.

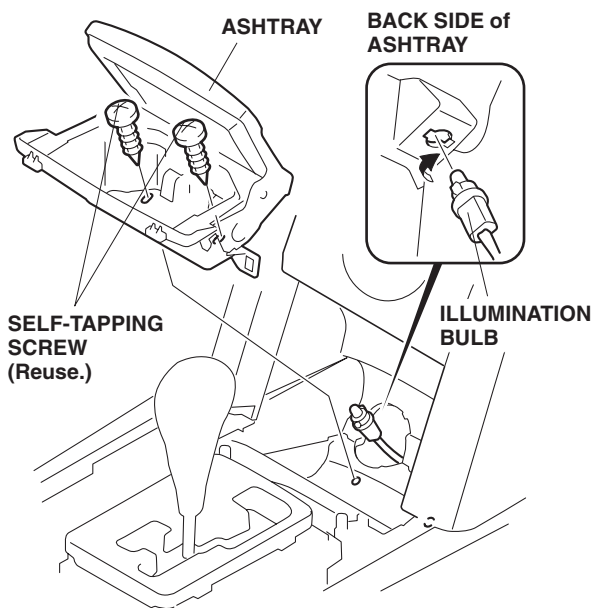

- Reinstall the center console trim.

- Install the new inner case to the ashtray.

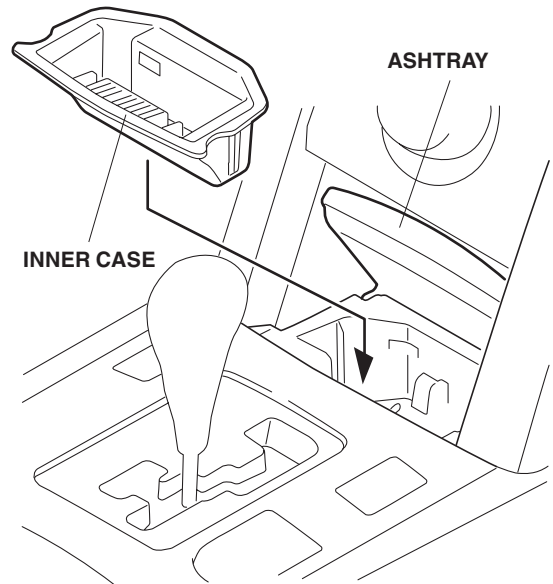

- Reconnect the negative cable to the battery.
- Open and close the ashtray several times to ensure that it works properly.
- Enter the anti-theft codes for the radio and navigation system, then enter the customer's radio presets.
- Reset the clock.

NOTE: Whenever the battery is disconnected, the driver's window AUTO function is disabled.

- Start the engine. Push down on the driver's window switch until the window is fully open.
- Pull up on the driver's window switch to close the window completely, then hold the switch for 2 seconds or more.
- Lower and raise the driver's window to check the operation of the driver's window AUTO function.
- Do the PCM idle learn procedure.
 - Make sure all electrical items are turned off.
 - Start the engine. Hold the engine speed at 3,000 rpm with no load (in Park or Neutral) until the radiator fan comes on.
 - Let the engine idle for about 10 minutes with the throttle fully closed and with all electrical items off.

NOTE: If the radiator fan comes on during this step, the time it is operating must not be included in the 10 minutes.