



INSTALLATION INSTRUCTIONS

Accessory

**RUNNING BOARD
P/N 08L33-S3V-200C**

Application

2005 MDX

Publications No.

BII 28229

Issue Date

SEP 2004

PARTS LIST

Right running board

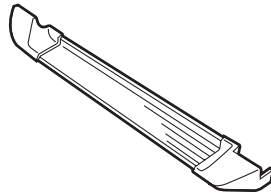

Left running board

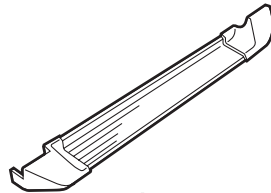

2 "A" Brackets



2 "B" Brackets

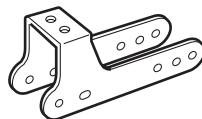

6 "C" Brackets

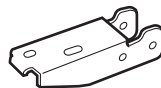

4 "AB" Brackets

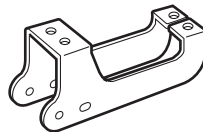

24 Long flange bolts



32 Short flange bolts



44 Flange nuts



TOOLS AND SUPPLIES REQUIRED

Ratchet

10 mm and 13 mm Sockets

10 mm and 13 mm Combination wrenches

Blanket

Torque wrench

INSTALLATION

Customer Information: The information in this installation instruction is intended for use only by skilled technicians who have the proper tools, equipment, and training to correctly and safely add equipment to your vehicle. These procedures should not be attempted by "do-it-yourselfers."

NOTE:

- Thoroughly clean the bottom of the body between the front and rear wheels.
- Be careful not to damage the body paint finish. To prevent damage, place a blanket under the running board during the installation.
- These instructions show the left side running board being installed; the same procedure applies to installing the right running board.

1. Assemble the two front bracket assemblies using brackets "A," "B," and "C" along with eight short flange bolts and eight flange nuts. Leave the nuts and bolts loose at this time.

Front Bracket Assembly:

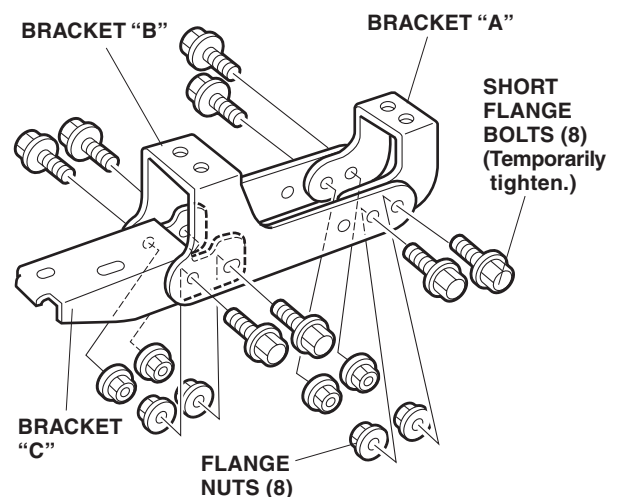

- Assemble four center and rear bracket assemblies using brackets "AB" and "C" along with four short flange bolts and four flange nuts. Leave the nuts and bolts loose at this time.

Center and Rear Bracket Assembly:

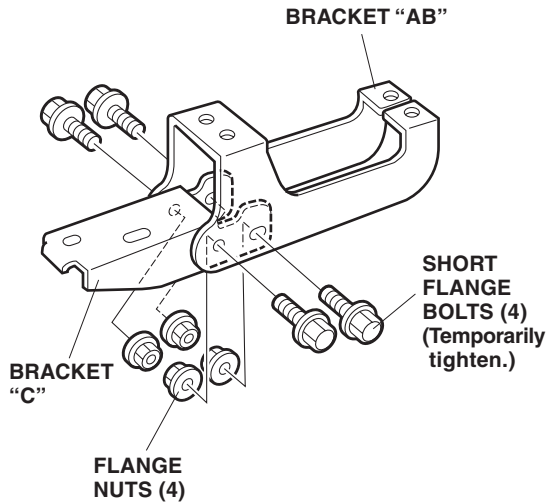

- On the left side of the vehicle, install one front bracket assembly, one center bracket assembly, and one rear bracket assembly along the body using twelve long flange bolts. Thread the long flange bolts in about three or four turns.

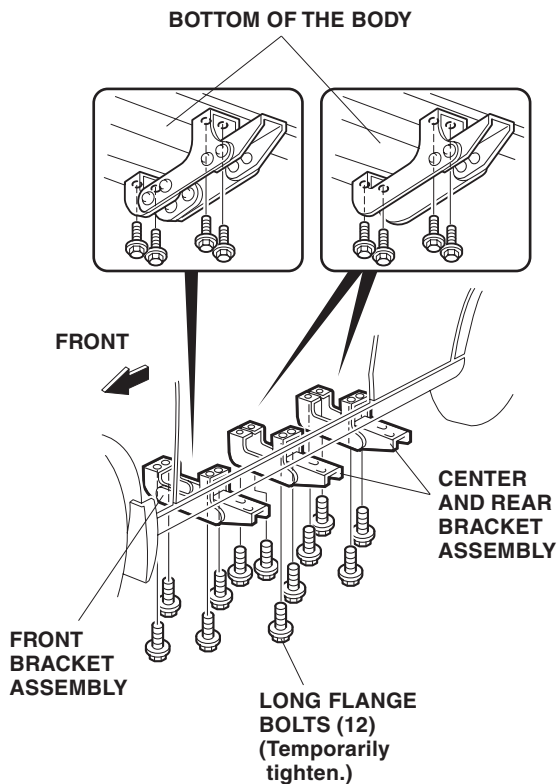

- Set the left running board on the brackets with the bolts through the holes in the brackets. Loosely install the six flange nuts on the bolts.

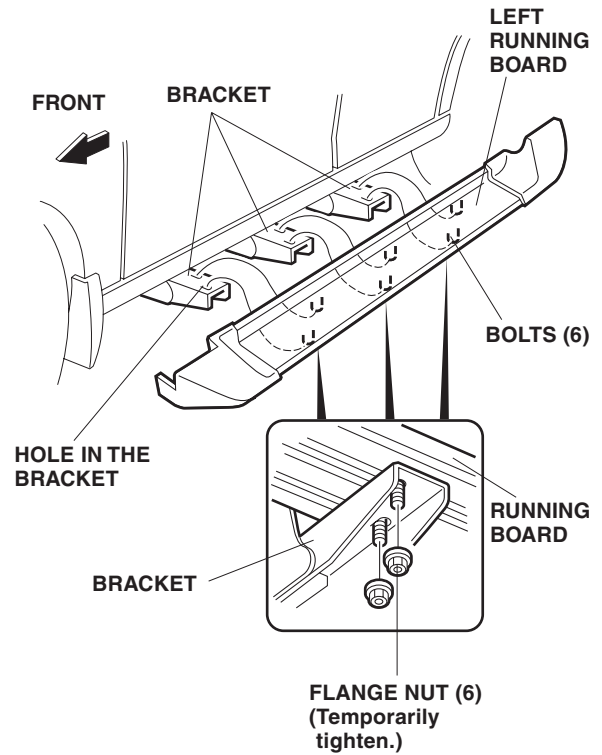

- Align the rear of the running board with the end of the side sill, then tighten the long flange bolts. Torque the long flange bolts to 27 N·m (20 lb-ft.)

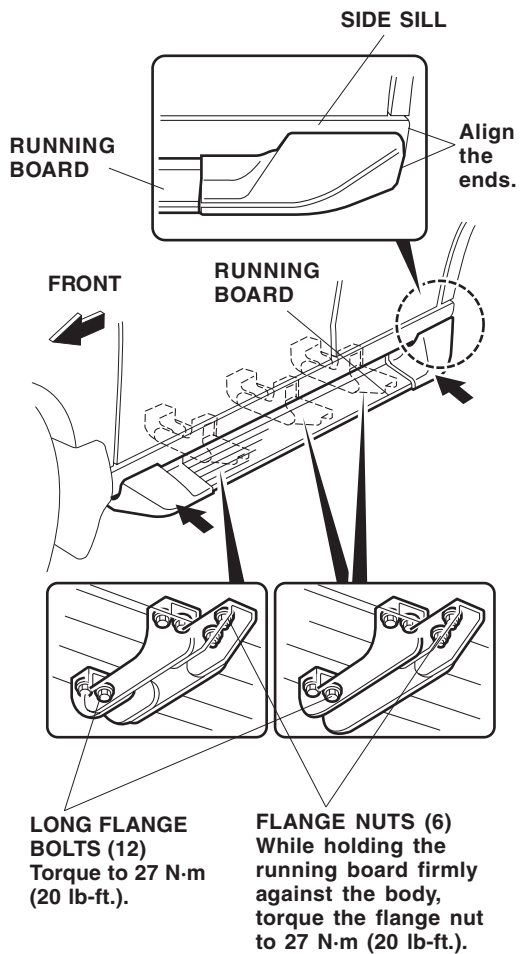

- Torque the short flange bolts to 27 N·m (20 lb-ft).
- While holding the running board firmly against the body, torque the flange nuts to 27 N·m (20 lb-ft.).
- Repeat steps 3 through 7 to install the running board on the right side of the vehicle.