



# INSTALLATION INSTRUCTIONS

Accessory  
**TRAILER HITCH**

Application  
**2004 MDX**

Publications No.  
**BII 25830**  
Issue Date  
**SEP 2003**

## PARTS LIST

**Trailer Hitch Kit:  
P/N 08L92-S3V-200A**

Trailer hitch

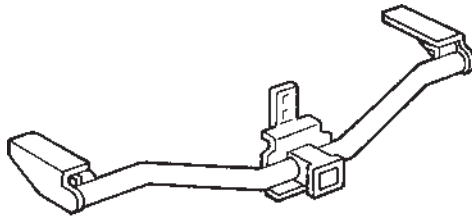

Ball mount



Hitch pin



Hitch pin clip



8 Bolts 12 x 40 mm



2 Bolts 10 x 32 mm



2 Bolts 8 x 20 mm



8 Plain washers 12 mm



2 Plain washers 10 mm



2 Plain washers 8 mm



8 Spring washers 12 mm



2 Spring washers 10 mm



2 Spring washers 8 mm



2 Spacers



2 Clips



Receiver cover



**Harness Kit:  
P/N 08L91-S3V-200**

Trailer hitch harness

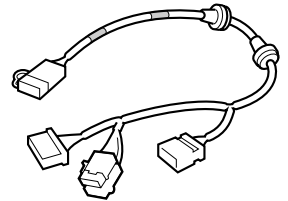

Converter

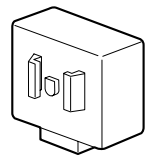

Unit bracket

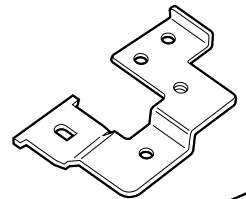

5 Wire ties

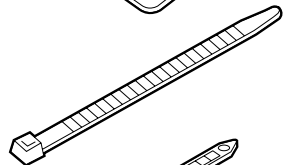

2 Black wire ties with clip

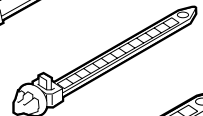

2 White wire ties with clip

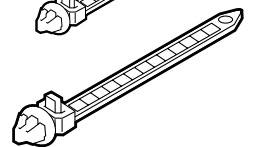

2 EPT sealers

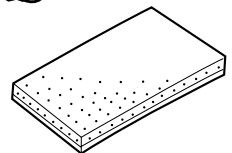

Fuse (15A)



Fuse label

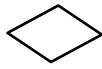

Owner's Manual

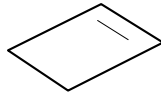

Red connector clip



3 Flange bolts, 6 x 16 mm



Harness connector bracket

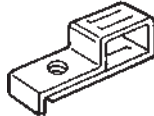

Nut



Fuse bracket

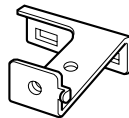

2 Connector clips



### TOOLS AND SUPPLIES REQUIRED

Phillips screwdriver

Clip remover

Diagonal cutters

Ratchet

10 mm, 12 mm, 13 mm, 17 mm and 19 mm sockets

Isopropyl alcohol

Shop towel

10 mm Wrench

Torque wrench

Scissors

Utility knife

### INSTALLATION

**Customer Information:** The information in this installation instruction is intended for use only by skilled technicians who have the proper tools, equipment, and training to correctly and safely add equipment to your vehicle. These procedures should not be attempted by "do-it-yourselfers."

### NOTE:

- Optional ATF and power steering coolers are required when installing the trailer hitch. Have the recommended coolers available so they can be installed.

- Be careful not to damage the rear bumper or other finished surfaces of the body.

1. Make sure you have the anti-theft code for the radio, then write down the radio station presets.
2. Disconnect the negative cable from the battery.

### Installing the Converter

3. Open the tailgate, and remove the cargo lid.

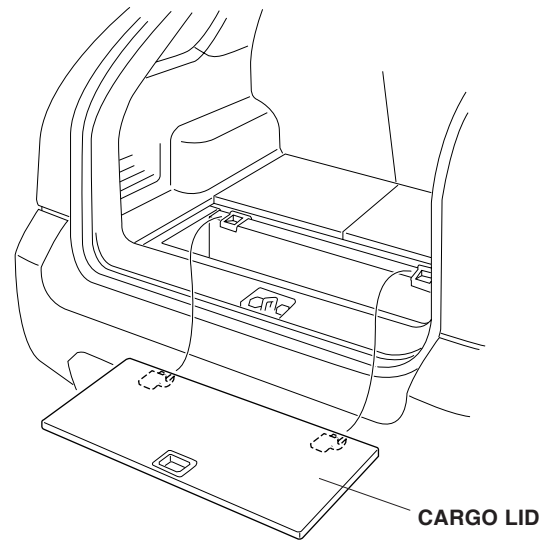

4. Remove the rear trim (two clips).

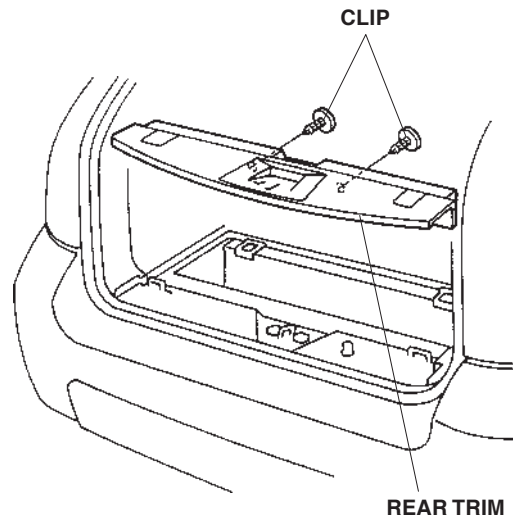

- Remove the bumper beam bracket (one bolt and one clip).

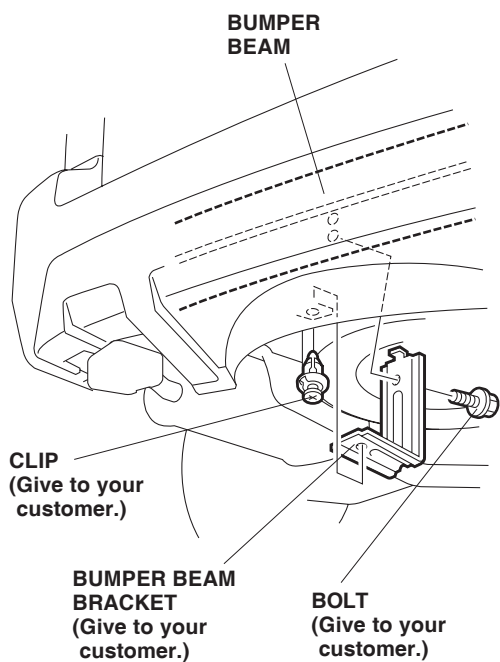

- Remove the four bolts and two clips that secure the under cover to the bottom of the rear bumper. Release the five retaining tabs and remove the under cover.

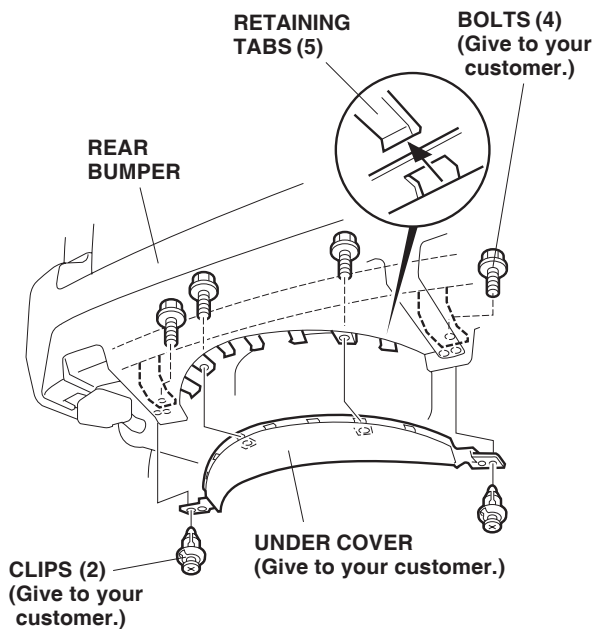

- Remove the two clip nuts from the rear bumper, then reinstall the rear bumper to the brackets with the two clips provided. Using diagonal cutters, cut the outboard retaining tabs from the rear bumper.

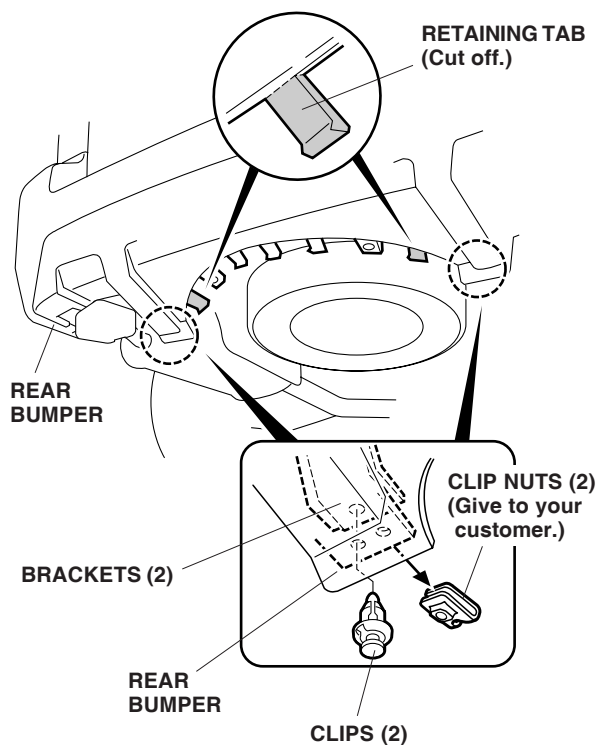

- Remove the large grommet from the bottom of the body frame.

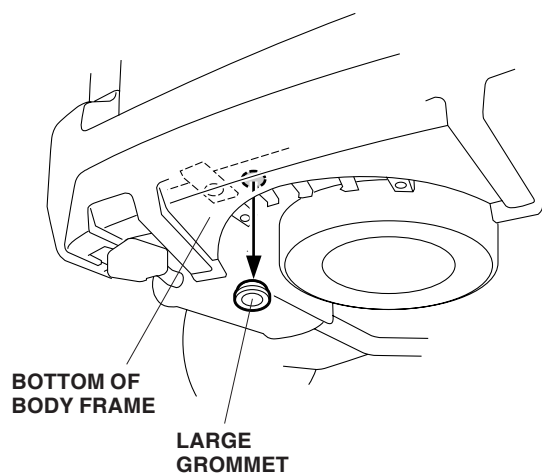

9. Inside the cargo area, remove the grommet from the body panel near the 6-pin connector on the left side of the vehicle.

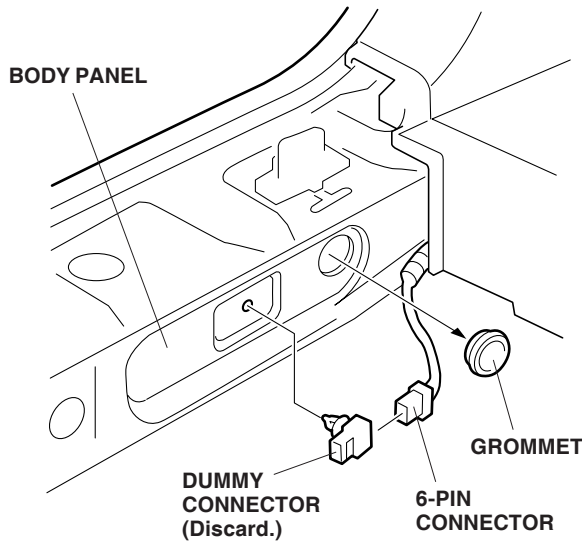

10. Remove the 6-pin connector from the body. Remove and discard the dummy connector from the 6-pin connector.
11. Inside the left of the cargo area, remove the self-tapping screw that secures the cargo lid hinge to the trunk floor. Pull the floor carpet out from the left rear side panel.

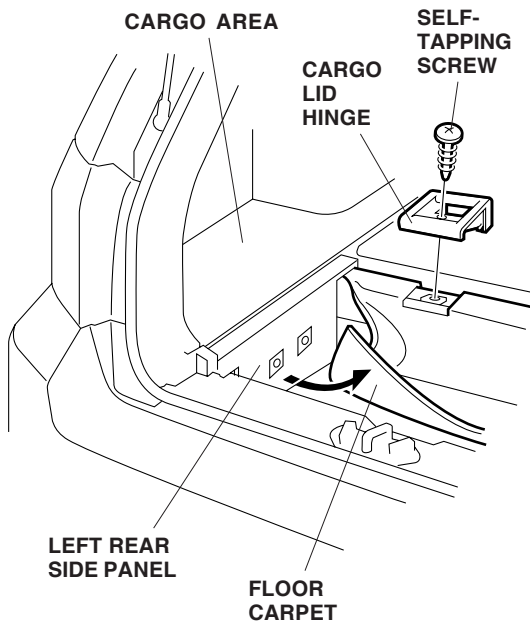

12. Turn the floor carpet over in the direction shown. Using a utility knife, cut the floor carpet between at the bottom of the second and third slits as counted from the left corner of the frame.

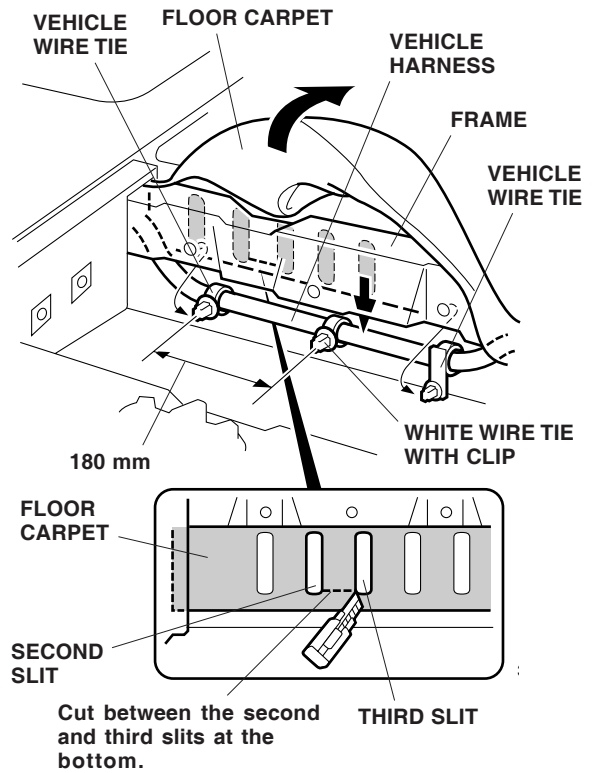

13. Remove the two vehicle wire ties with clip that secure the vehicle harness to the frame. Lower the vehicle harness, then attach one white wire tie with clip to the vehicle harness at the measurement shown.
14. Slide the converter bracket onto the converter.

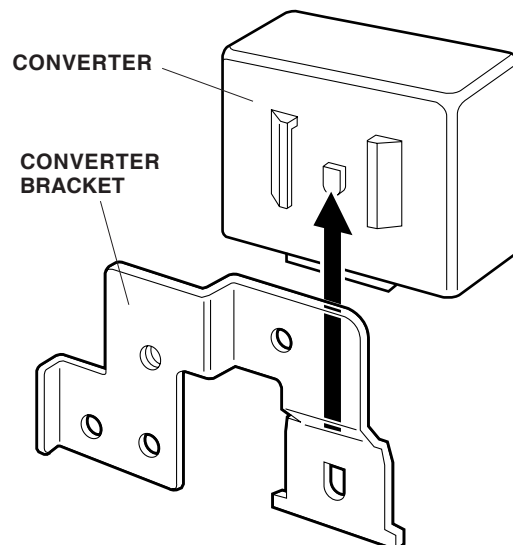

- Attach the other white wire tie with clip to the trailer hitch harness at the measurement shown.

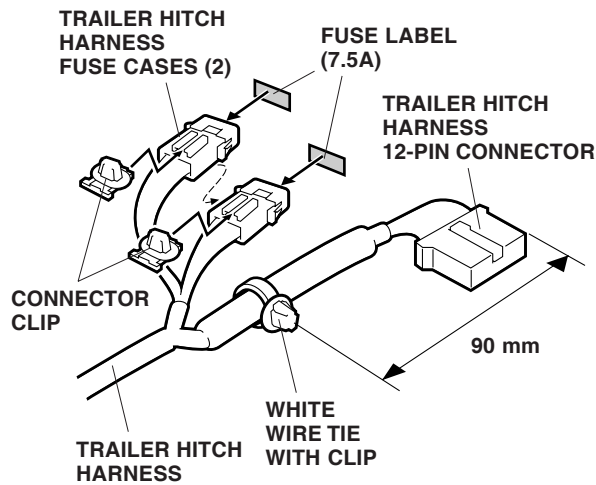

- Separate the trailer hitch harness fuse cases, then slide one connector clip onto each fuse case. Attach one 7.5A fuse label to each of the fuse case.
- Wrap one full EPT sealer around the trailer hitch harness at the measurement shown.

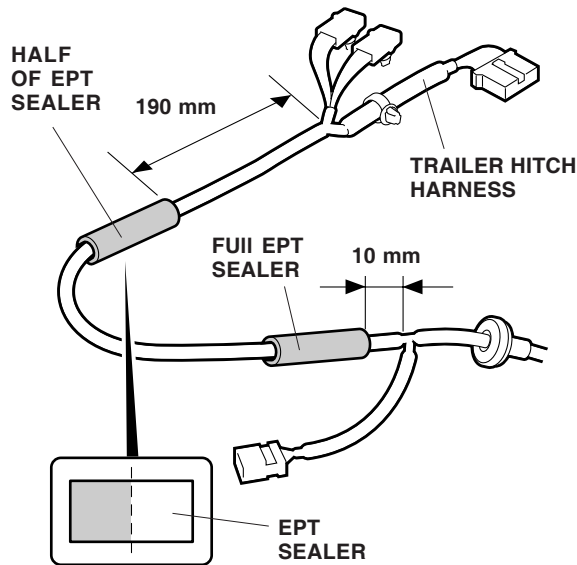

- Using scissors, cut one EPT sealer in half. Wrap half of the EPT sealer around the trailer hitch harness at measurement shown.

- Plug the trailer hitch harness 12-pin connector into the trailer unit.

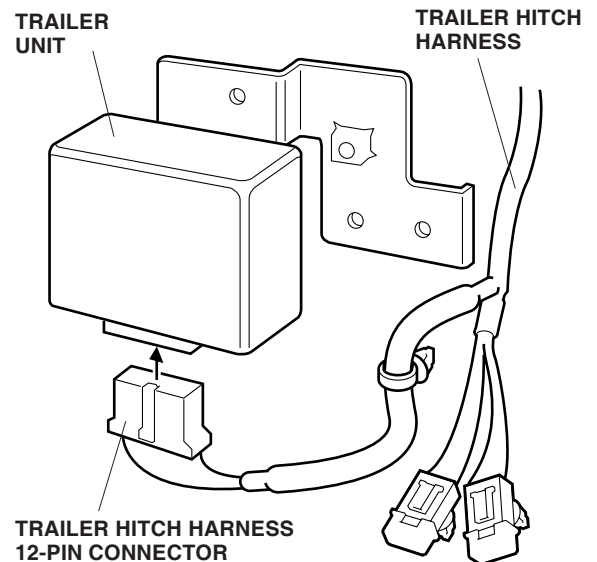

- Push the clip of the white wire tie with clip (installed in step 13) into the hole in the unit bracket.

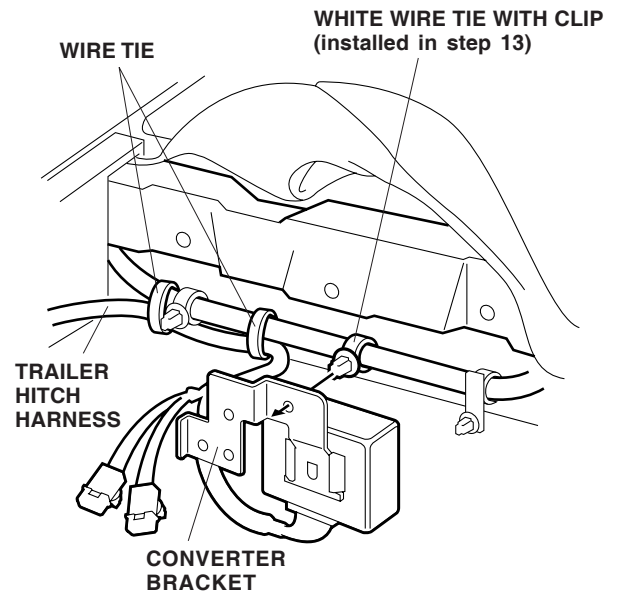

- Secure the trailer hitch harness to the vehicle harness with the two wire ties in the areas shown.

22. Position the converter bracket on the frame and install the flange bolt. Reinstall the vehicle wire ties with clip removed in step 13.

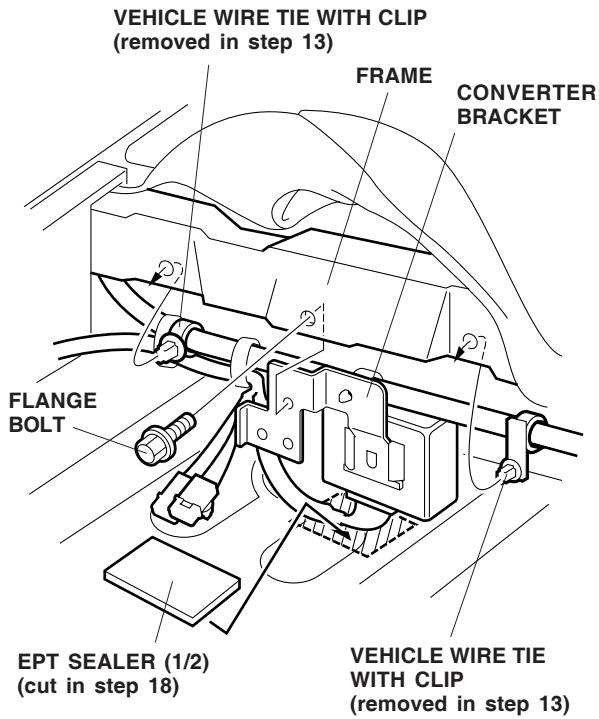

23. Using isopropyl alcohol on a shop towel, clean the floor panel where the EPT sealer will attach. Install the remaining half of the EPT sealer to the floor panel.

24. Position the fuse bracket on the converter bracket and install the flange bolt.

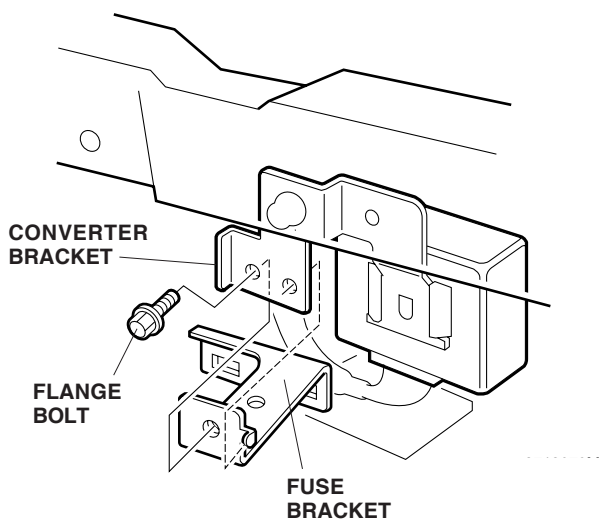

25. Push the white wire tie with clip attached to the trailer hitch harness 12-pin connector into the hole in the fuse bracket. Push the fuse case connector clip into each of the holes in the fuse bracket.

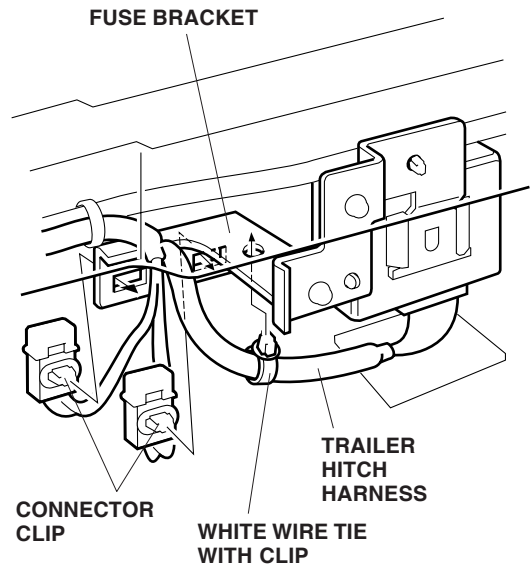

26. Tuck the floor carpet and trailer hitch harness under the left rear side panel.

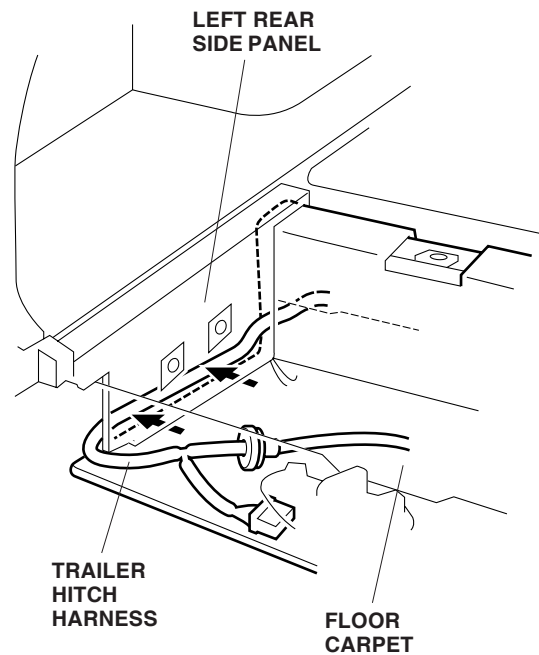

27. Slide one red connector clip onto the trailer hitch harness 6-pin connector, then plug the vehicle 6-pin connector into the trailer hitch harness 6-pin connector.

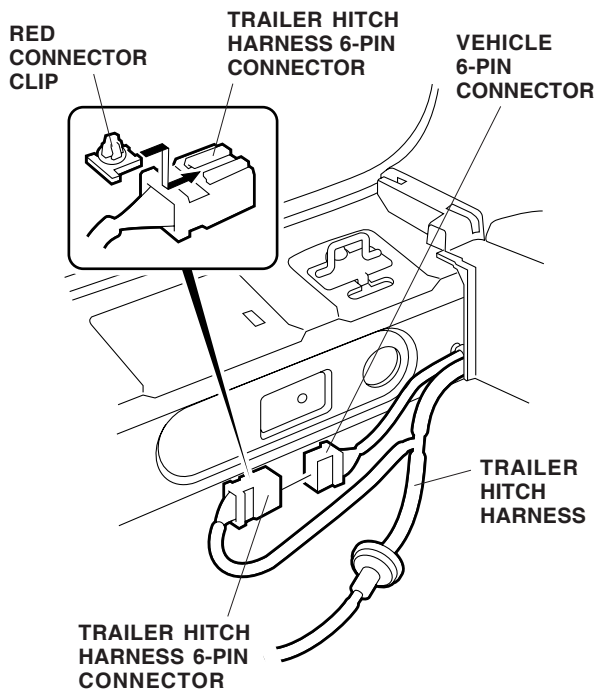

28. Push the red connector clip into the hole in the rear panel where the vehicle 6-pin connector clip was installed. Secure the trailer hitch harness to the vehicle harness with the two wire ties.

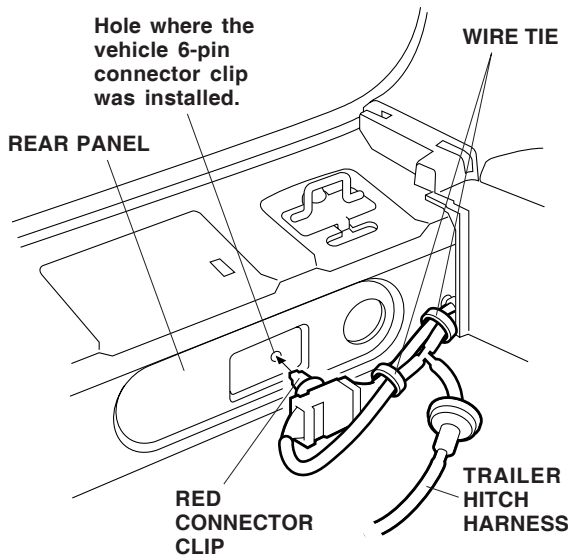

29. Route the trailer hitch harness 4-pin connector through the hole in the rear panel, and out through the hole in the bottom body panel.

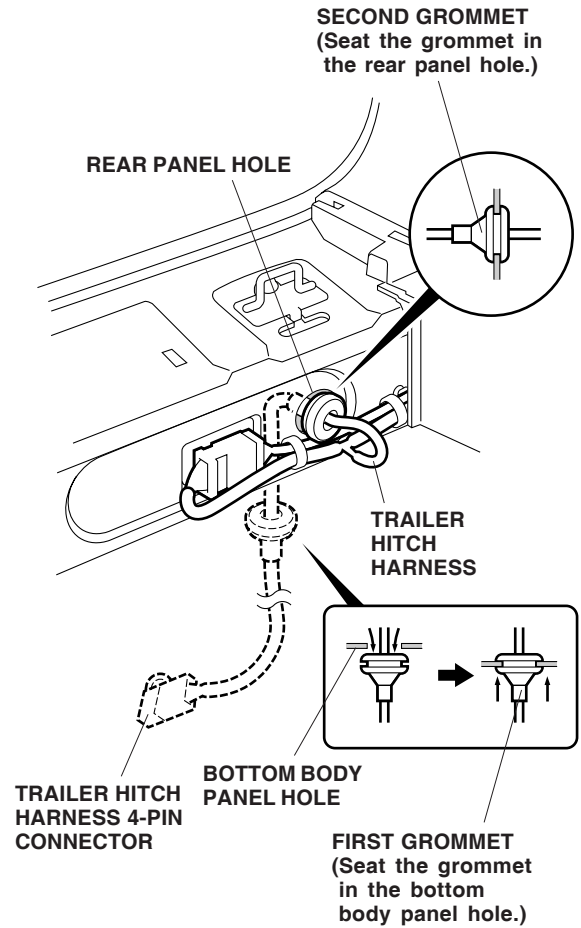

30. Pull the first grommet through the hole in the rear panel, and seat the first grommet in the bottom body panel hole. Seat the second grommet in the rear panel hole.

## Installing the Hitch

31. Remove the tow hook (three bolts).

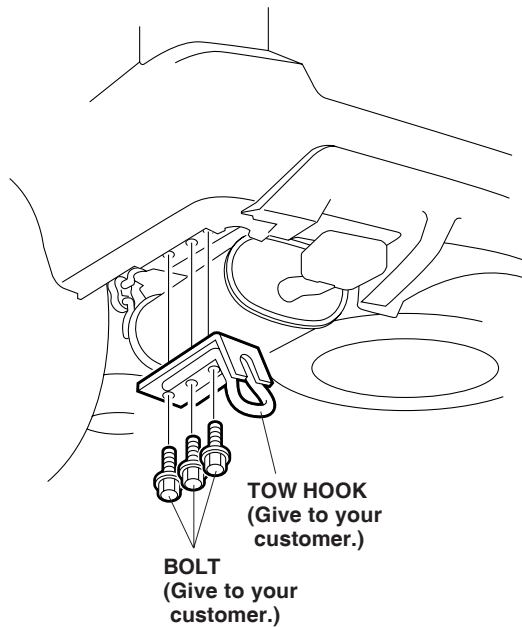

32. When the exhaust system is cooled down, remove the two rubber mounts that secure the left muffler to the body. Remove the two rubber mounts that secure the right muffler to the body, then carefully lower the exhaust system.

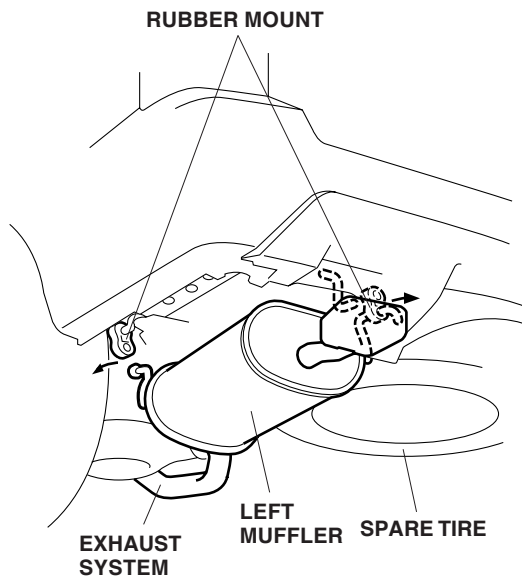

33. Using a 19 mm socket, lower the spare tire.

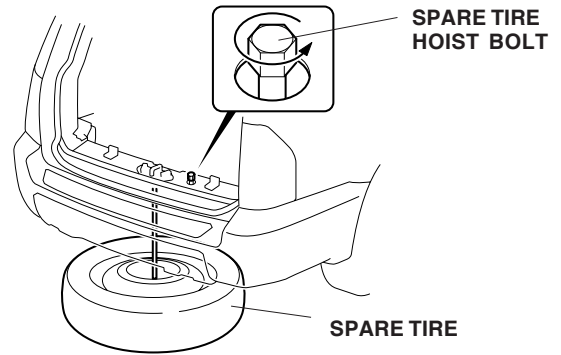

34. With the help of an assistant, tilt the trailer hitch into position avoiding the heat shields, and install the trailer hitch to the body, using the eight 12 x 40 mm bolts, eight 12 mm plain washers, and eight 12 mm spring washers.

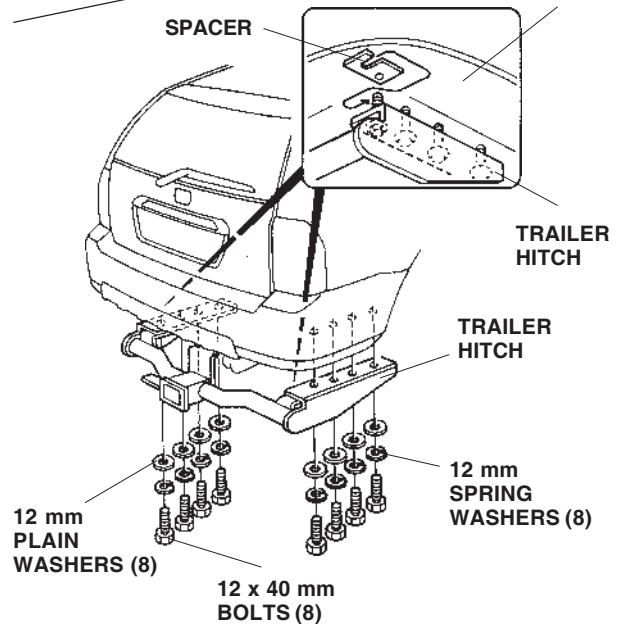
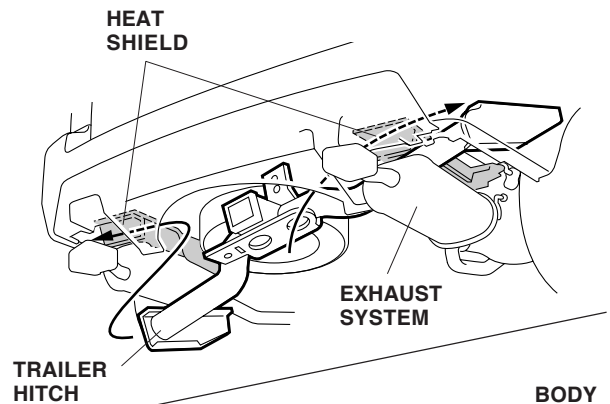

35. Insert one spacer on each side between the trailer hitch and the body at the rear bolts. Do not tighten the trailer hitch at this time.

36. Loosely install the two 10 x 32 mm bolts, and two 8 x 20 mm bolts, all with plain washers, and spring washers.

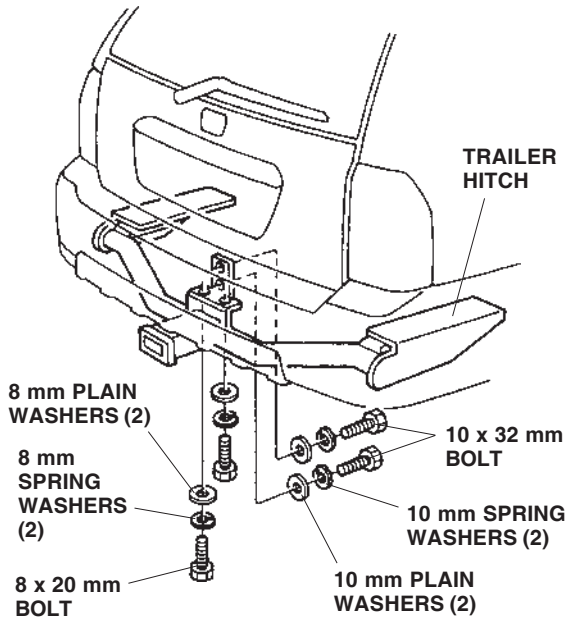

37. Torque the trailer hitch mounting bolts in this order:

**1**

- Two 8 x 20 mm bolts to 23 N·m (17 lb-ft).

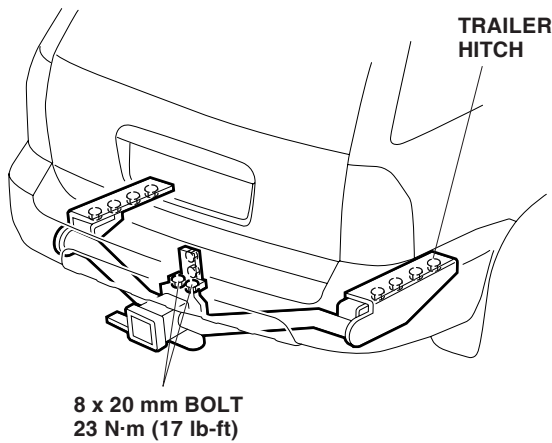

**2**

- Two 10 x 32 mm bolts to 46 N·m (34 lb-ft).

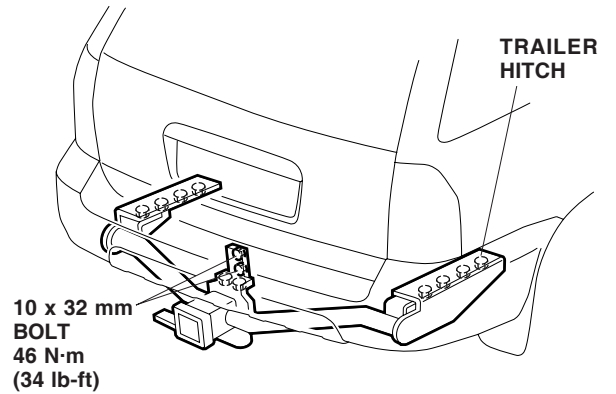

**3**

- Eight 12 x 40 mm bolts (installed in step 34) to 79 N·m (58 lb-ft).

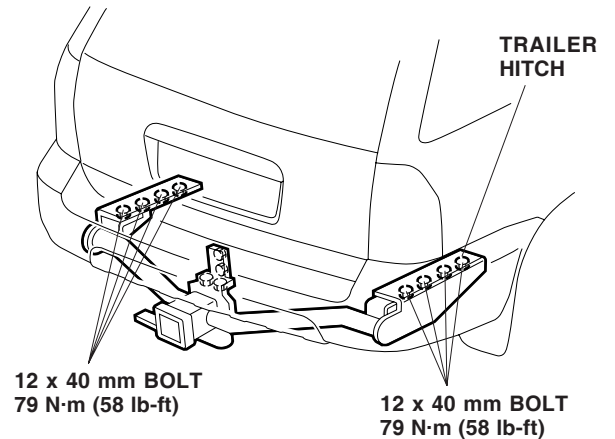

38. Attach the two black wire ties with clips to the trailer hitch harness at the green tapes, then push the clips into the holes in the rear bumper beam.

If the vehicle is equipped with backup sensors, cut the clip from one black wire tie with clip, align the green tapes from the backup sensor and trailer hitch harnesses, and secure the harnesses with the cut wire tie.

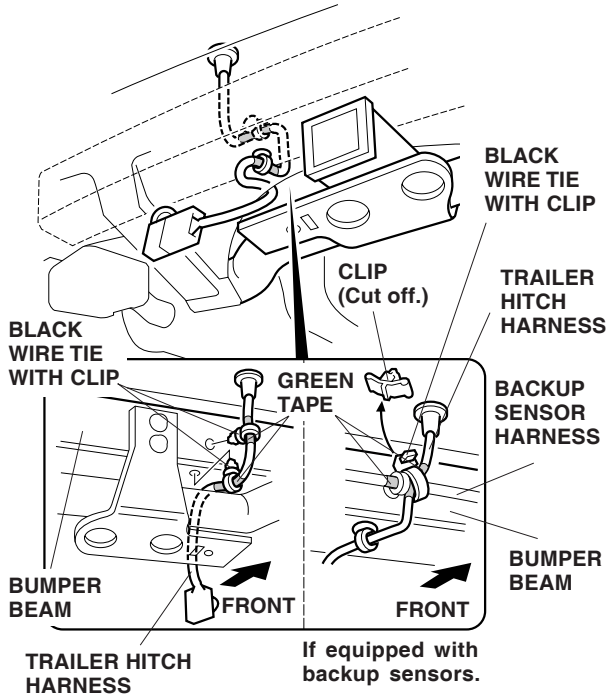

39. Attach the trailer hitch harness connector to the harness connector bracket on the trailer hitch with the 6 x 16 mm flange bolt and nut.

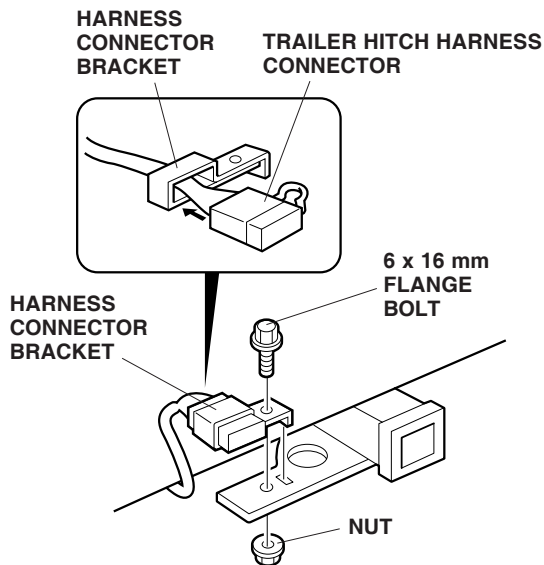

40. Secure the trailer hitch harness to the trailer hitch with one wire tie.

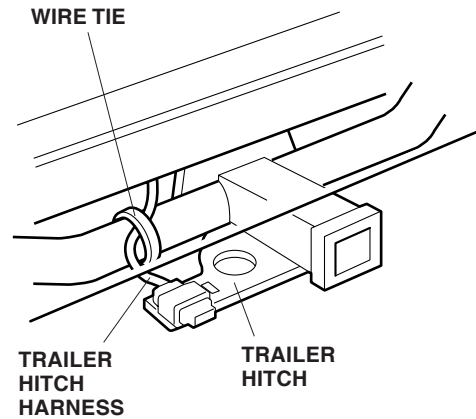

41. Slide the ball mount into the opening at the end of the trailer hitch. Insert the hitch pin through the trailer hitch and ball mount, then install the hitch pin clip in the hole in the end of the hitch pin.

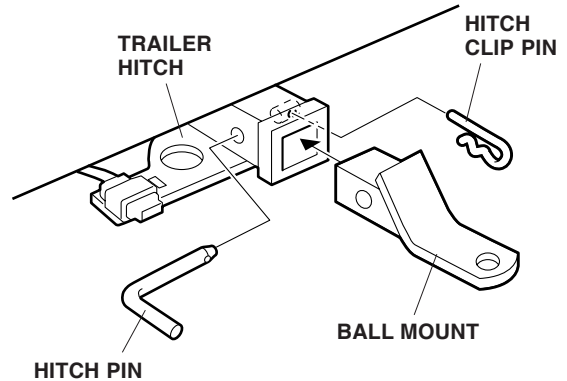

42. Reinstall the rubber mounts that secure the exhaust system, and raise the spare tire back into position.
43. Reinstall the rear trim and the cargo lid.

44. Inside the engine compartment, open the secondary fuse box cover, and install the 15A fuse into the empty slot of the fuse box.

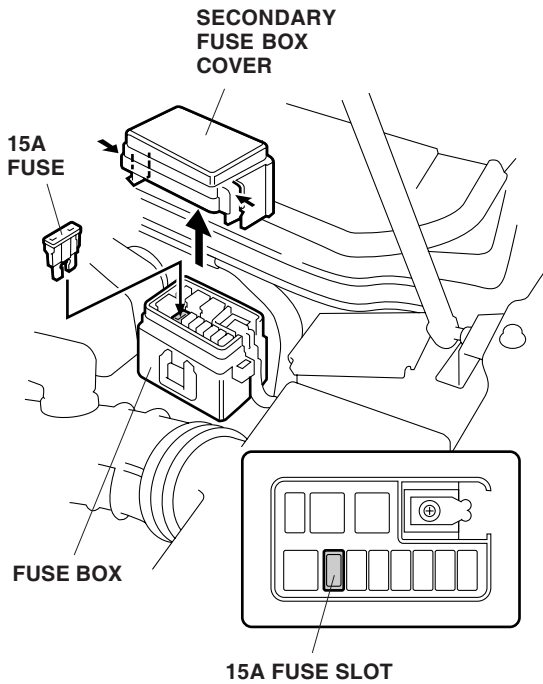

45. Attach the 15A fuse label to the secondary fuse box cover in the location shown. Reinstall the fuse box cover.

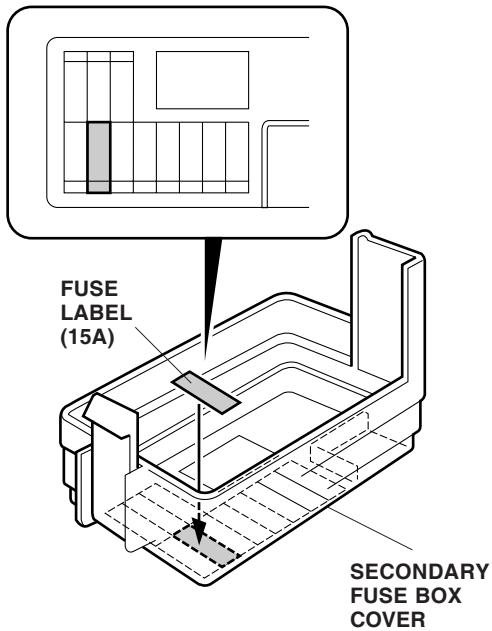

46. Reconnect the negative cable to the battery.  
47. Enter the customer's radio anti-theft code, and reset the radio station presets.  
48. Reset the clock.

NOTE: Whenever the battery is disconnected, the driver's window AUTO function is disabled.

49. Start the engine. Push down on the driver's window switch until the window is fully open.  
50. Pull up on the driver's window switch to close the window completely, then hold the switch for 2 seconds or more.  
51. Lower and raise the window to check operation of the driver's window AUTO function.

**Give a copy of this page to your customer**

### **Installing the Receiver Cover**

Whenever you remove the hitch pin clip, the hitch pin, and the ball mount, store them securely in the cargo area. Install the receiver cover into the opening at the end of the trailer hitch. When you reinstall the ball mount, store the receiver cover in the cargo area. After the first 600 miles (1,000 km) of towing, have your Honda Dealer recheck the tightness of the trailer hitch bolts.

