



INSTALLATION INSTRUCTIONS

Accessory

SEPARATION NET
P/N 08U36-S3V-201

Application

2004 MDX

Publications No.

BII 25825

Issue Date

SEP 2003

Keep this information in the glove box for future reference.

PARTS LIST

Separation net

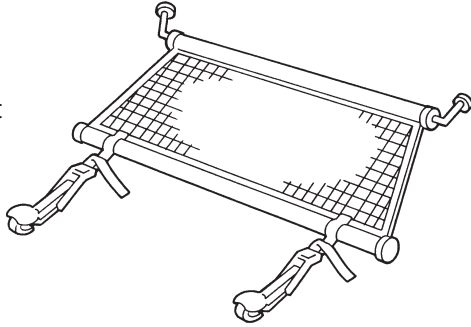

TOOLS REQUIRED

Small flat-tip screwdriver

INSTALLATION

NOTE: These instructions show the separation net being installed on the right side of the vehicle; the same procedure applies to installing the separation net on the left side of the vehicle.

1. Using a small flat-tip screwdriver or the ignition key, release the seat belt lower hook from each third row seat; then attach the seat belt clip to the seat belt.

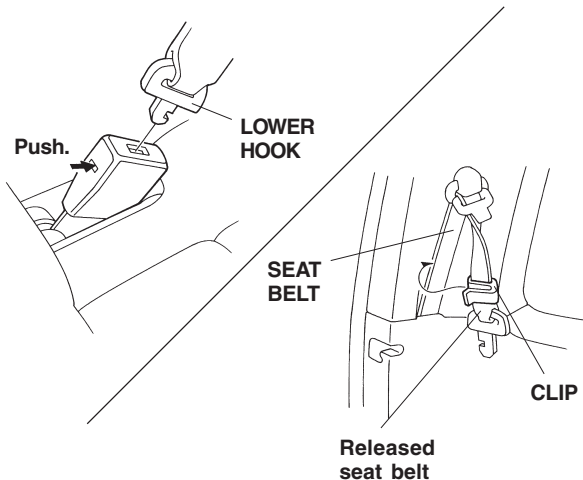

2. Remove the headrests by pushing the release buttons and pulling the headrests out.

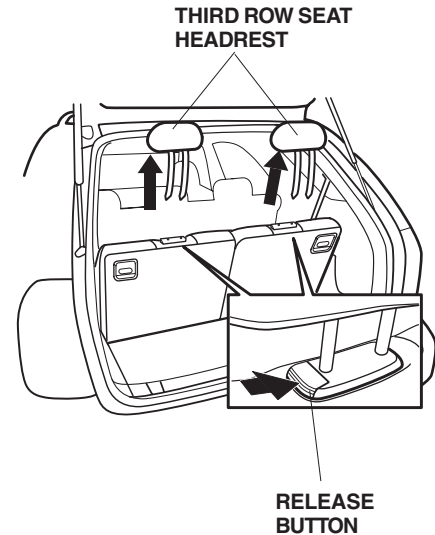

3. Store the headrests in the storage compartment under the cargo floor. Insert the shafts of the headrests into the holes in the sides of the storage compartment.

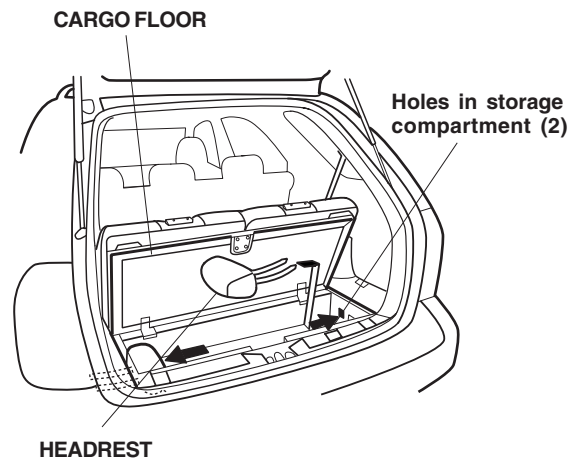

4. Fold down both third row seats.

- Above the rear quarter windows, locate and open the two covers.

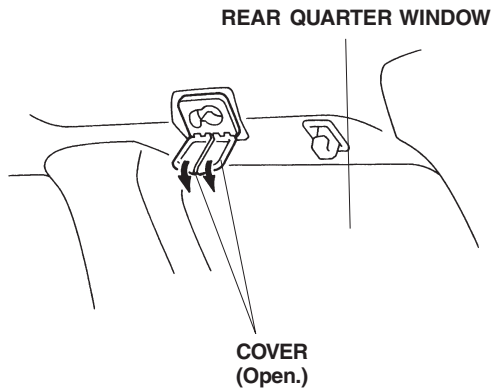

- Insert the rod on the end of the separation net into the uncovered holes, and slide it down into position.

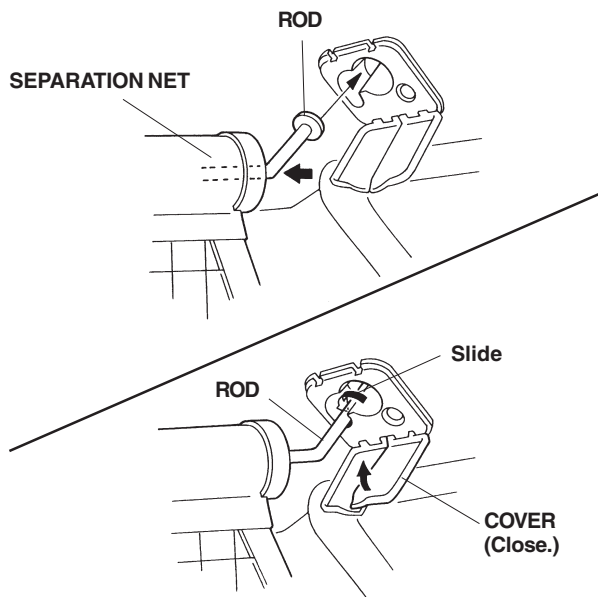

- Close the two covers.

- Extend the "S" hook of the separation net, then attach the "S" hook to the "D" ring on the floor.

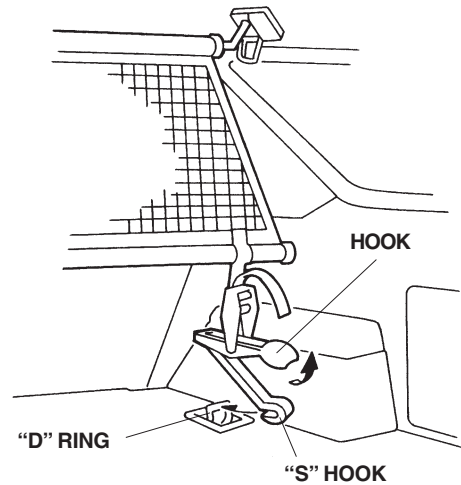

- Adjust the length of the strap as needed to lower the hook onto the "S" hook, then attach the strap to the Velcro.

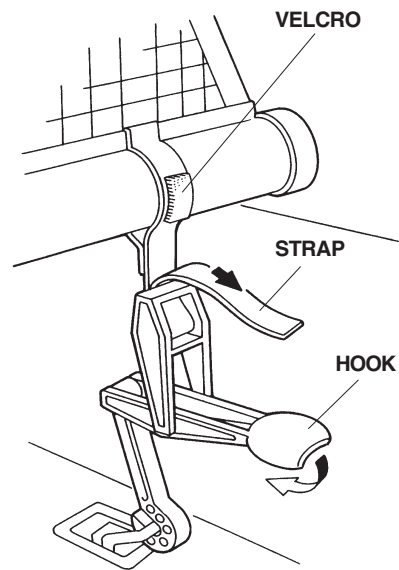

- Repeat steps 8 and 9 on the other side.

NOTE:

- Do not allow the height of the cargo to exceed the seat-back of the second seat in the cargo area.
- Be sure to lay the cargo directly on the floor if it is heavy.
- Do not hang from the frame or net, or hang heavy articles on the net.
- After installing the net, check that the upper rod is secured properly and the lower strap is pulled taut. Cargo may shift while driving if the separation net is not attached properly.