



# INSTALLATION INSTRUCTIONS

Accessory

**DOOR VISOR**  
P/N 08R04-S3V-200

Application

**2004 MDX**

Publications No.

**BII 25811**

Issue Date

**SEP 2003**

## PARTS LIST

Door visor (Left front)

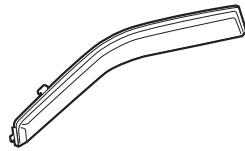

Door visor (Right front)

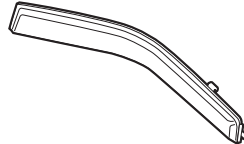

Door visor (Left rear)



Door visor (Right rear)



## SUPPLIES REQUIRED

Isopropyl alcohol

Shop towel

Masking tape

## INSTALLATION

### NOTE:

- These instructions show the left door visors being installed. The same procedure applies to installing the right door visors.
- Be careful not to damage the body paint finish and glass run channels when installing the door visors.
- Handle the door visors with care. They are not designed to absorb shock or impact.
- To prevent damaging the surface, do not use ammonia-based cleaners or solvents to clean the door visors.
- These door visors should be installed only if the ambient air temperature is 60°F (15°C) or above.
- After installing the door visors, hold them firmly against the door sashes with the palm of your hand.
- To allow the adhesive to cure, do not wash the vehicle for 24 hours.

## Installing the Front Door Visor

1. Lower the front door glass completely. Use plastic trim tools to remove the door glass run channel from the door sash in the area shown. Do not remove the glass run channel from the door mirror base or the rear door edge.

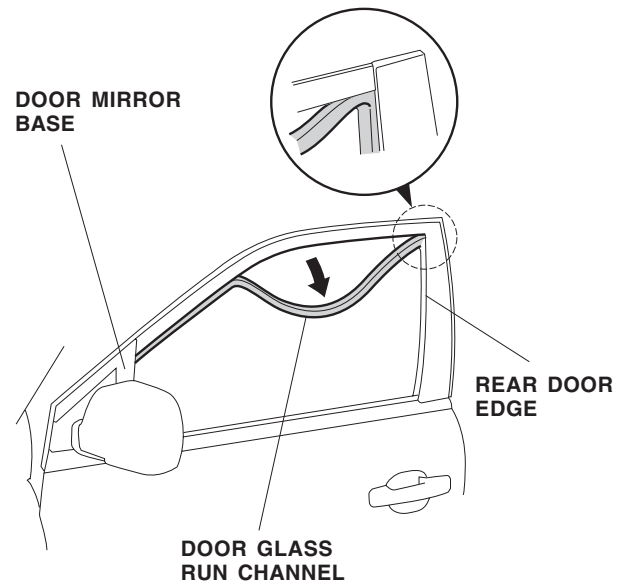

2. Using isopropyl alcohol on a shop towel, clean the shaded area of the door sash.

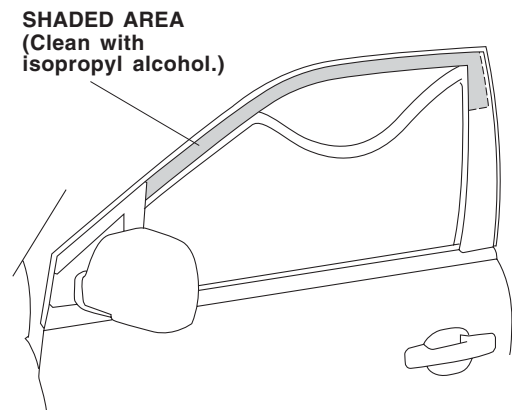

- Attach a strip of masking tape to the end of the front adhesive backing at the front of the door visor. Remove 40 to 50 mm of adhesive backing, and tape the end of the backing to the inside of the door visor.

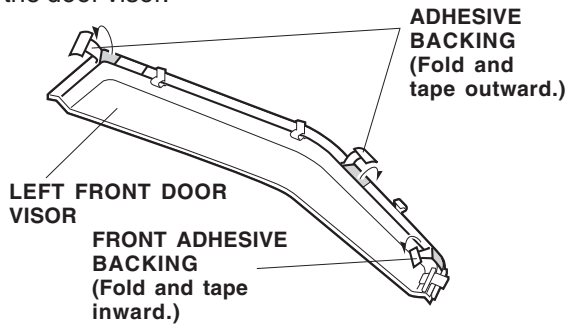

- Attach a strip of the masking tape to the ends of the remaining adhesive backings. Remove 40 to 50 mm of the adhesive backing, and tape the ends of the backings to the outside of the door visor. Note the removal direction of the adhesive backings.
- Attach the front bracket of the door visor to the door sash, and insert the front tab of the door visor under the door mirror base. Push the two rear brackets onto the door sash, as shown.

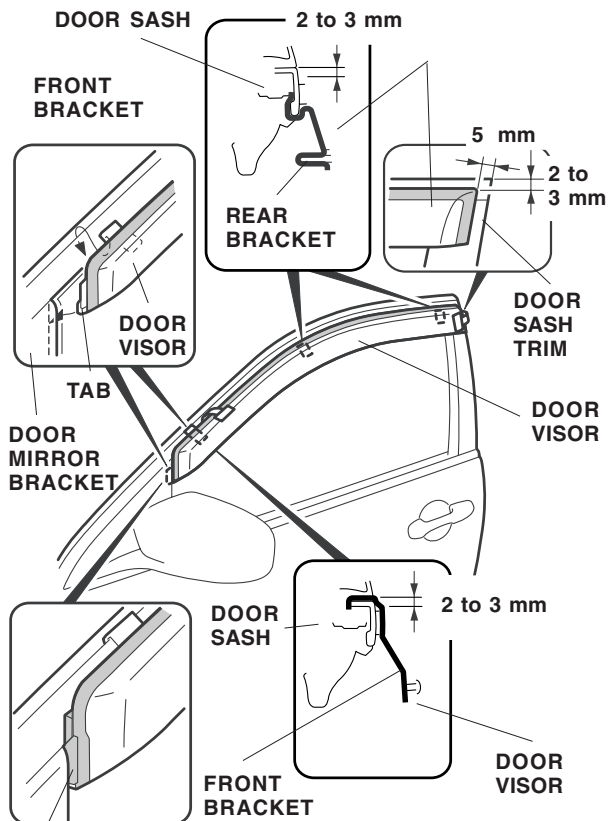

**EPT SEALER**  
There is no clearance between the EPT sealer and the body at the front of the door visor.

- Adjust the location of the door visor so the clearance between the door visor and door sash trim is 5 mm at the rear of the door, and the gap along the top edge of the door visor is 2 to 3 mm. There should be no clearance between the front tab and the door visor. Check that there is no clearance between the door visor and mirror base.
- While holding light pressure on the door visor, carefully remove the adhesive backings in the directions shown. Using the palm of your hand, hold the door visor firmly against the door for 30 seconds.

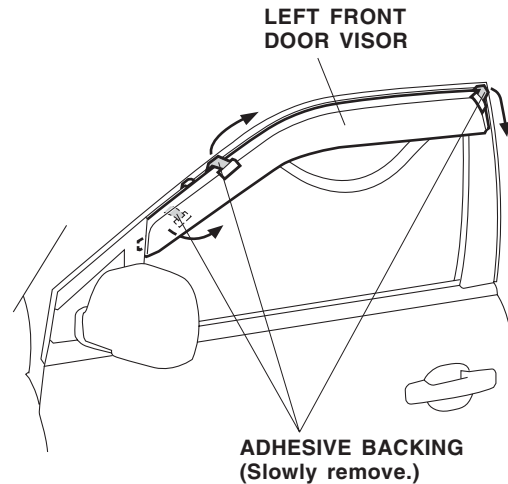

- Reinstall the door glass run channel.  
**NOTE:** Make sure the door glass run channel is seated properly.

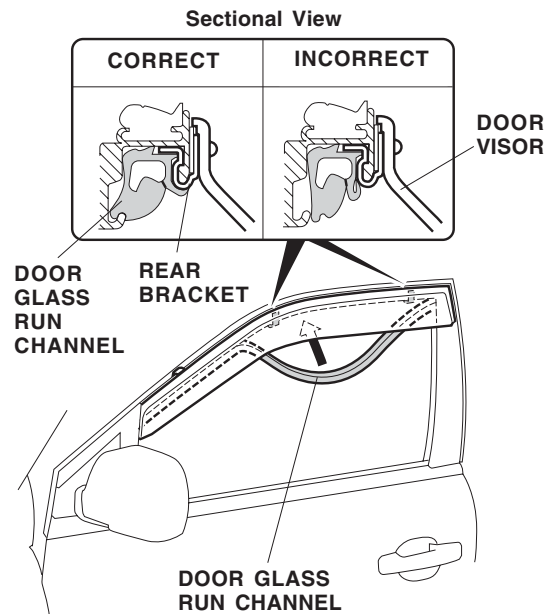

- Repeat steps 1 thru 8 to install the right front door visor.

## Installing the Rear Door Visor

10. Lower the rear door glass completely. Use plastic trim tools to remove the door glass run channel from the door sash in the area shown.

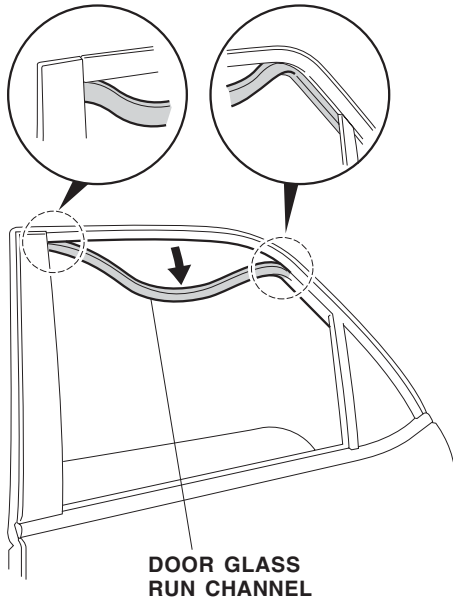

11. Using isopropyl alcohol on a shop towel, clean the shaded area of the door sash.

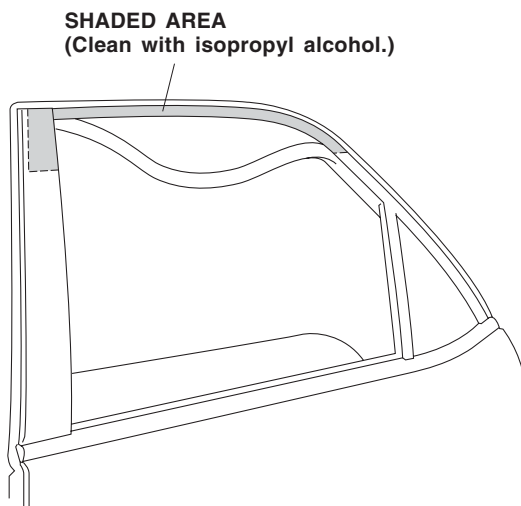

12. Attach a strip of masking tape to the ends of the adhesive backings. Remove 40 to 50 mm of adhesive backings, and tape the ends of the backings to the outside of the door visor as shown.

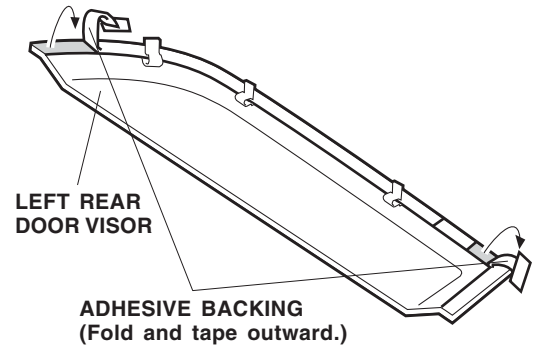

13. Attach the three brackets of the door visor to the door sash, and position the door visor as shown.

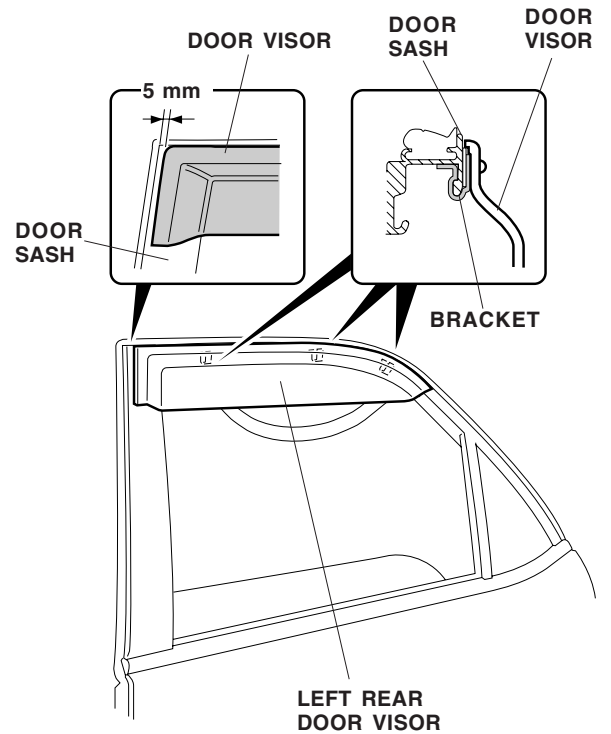

14. Adjust the location of the door visor so the clearance between the door visor and door sash trim is 5 mm at the front of the door.

15. While holding light pressure on the door visor, carefully remove the adhesive backings in the directions shown. Using the palm of your hand, hold the door visor firmly against the door for 30 seconds or more.

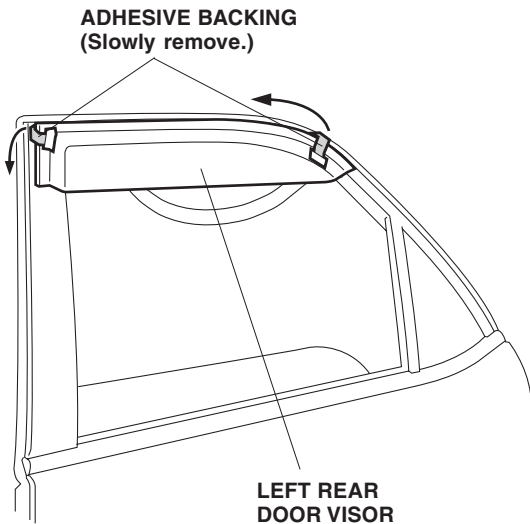

16. Reinstall the door glass run channel.
- NOTE: Make sure the door glass run channel is seated properly.

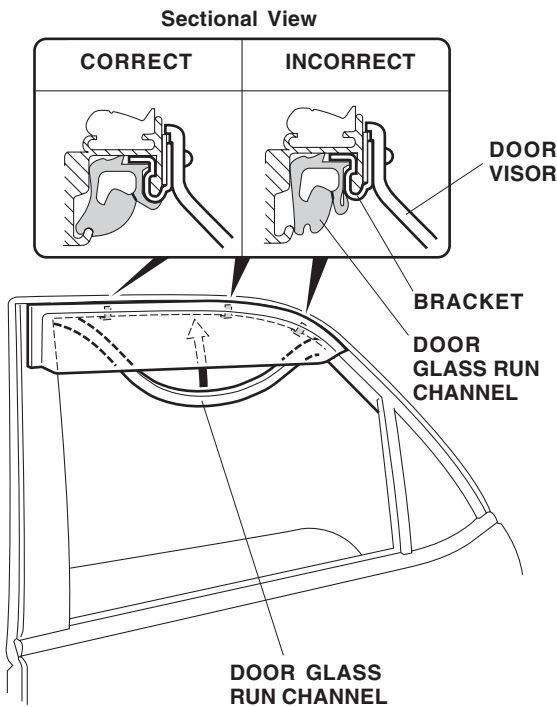

17. Repeat steps 10 thru 16 to install the right rear door visor.

## Resetting the Window Auto Function

17. Turn the ignition switch OFF.
18. Remove the driver's side power window 20A fuse from the under-hood subfuse box.
19. Reinstall the the driver's side power window 20A fuse to the under-hood subfuse box.
20. Turn the ignition switch to the ON (II) position.
21. Lower the driver's window all the way down and continue to hold the switch in the down position for an additional 2 seconds.
22. Raise the driver's window fully and continue to hold the switch in the up position for an additional 2 seconds or more.
23. Check that the AUTO down and AUTO up features work properly. If not, repeat the reset procedure.

## USE AND CARE

- To clean the door visor, wipe it with a soft cloth dampened with clean water.
- To remove dust and dirt, clean with a solution of liquid dishwashing soap and water using a soft cloth or chamois. Never use organic solvents such as thinner, benzine, alcohol, etc., or abrasive cleaners.