



INSTALLATION INSTRUCTIONS

Accessory
AIR DEFLECTOR (NARROW)

Application
2004 MDX

Publications No.
BII 25798
Issue Date
SEP 2003

PARTS LIST

Air deflector

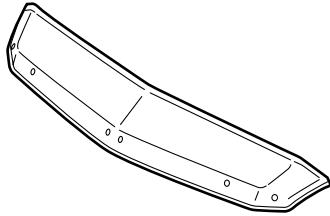

2 Front brackets

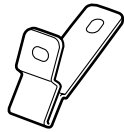

Right bracket

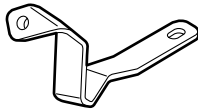

Left bracket

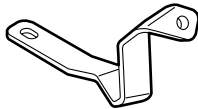

Center bracket

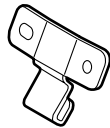

2 Collars



3 Washers



3 Alcohol pads

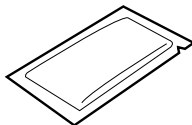

4 Clips



Hood label

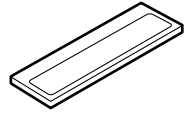

6 Protective tapes

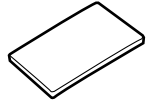

2 Plastic grommets



2 Long screws



4 Short screws



Center support

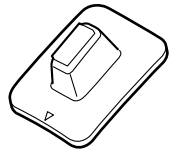

2 Rivnuts 6 x 1.0 mm

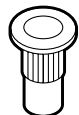

Rubber molding

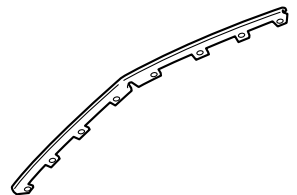

TOOLS AND SUPPLIES REQUIRED

#2 Phillips screwdriver

Tape measure

Felt-tip pen

Shop towel

Masking tape

Drill

3 mm, 6 mm, and 10 mm Drill bits

File

Touch-up paint

Eye protection (face shield, safety goggles, etc.)

Rivnut tool, 6 x 1.0 mm (Available through the Honda

Tool and Equipment Program (888) 424-6857)

INSTALLATION

Customer Information: The information in this installation instruction is intended for use only by skilled technicians who have the proper tools, equipment, and training to correctly and safely add equipment to your vehicle. These procedures should not be attempted by "do-it-yourselfers."

NOTE:

- Be careful not to damage the body finish when you install the air deflector.
- This air deflector should be installed only when the ambient air temperature is 60°F (15°C) or above.

1. Open the hood. On the inside of the hood, draw a line through the centers of the square and round holes for each side with a felt-tip pen. From the center of the round hole, measure 76 mm toward the square hole and mark the hood on the line. Measure and mark the right side of the hood the same way.

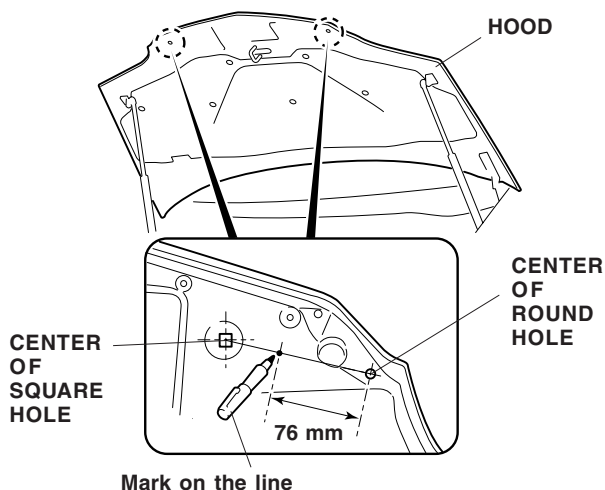

2. While wearing eye protection, drill a 10 mm hole through each of the two marks.
 - To prevent metal shavings from entering the engine compartment, use a shop towel to cover the engine before drilling the holes.
 - To prevent drilling through the inner panel, use a drill stop or masking tape 10 mm from the end of the drill bit.
 - First drill with a 3 mm drill bit, then with a 6 mm drill bit, and finish with a 10 mm drill bit.
 - After drilling, remove any burrs from the edges of the holes with a file. Apply touch-up paint, and allow the touch-up paint to dry thoroughly.
 - Clean all metal shavings. Be careful not to damage the body paint, and remove the shop towel.

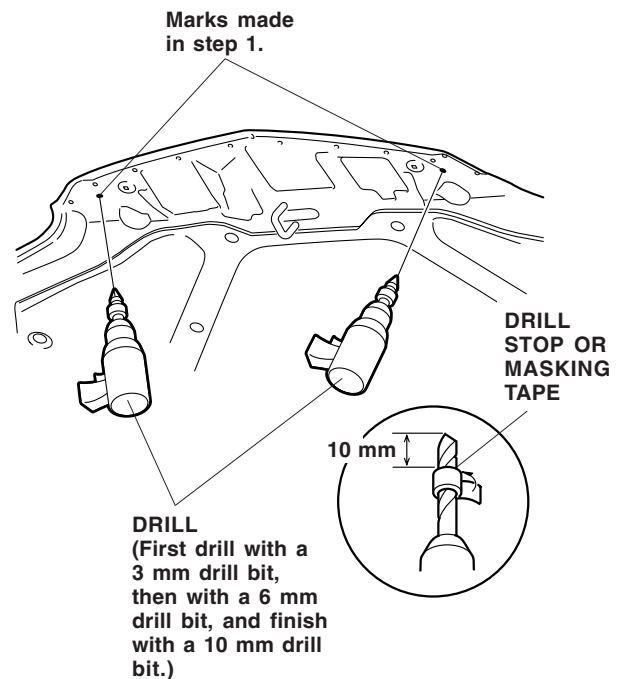

3. Insert one rivnut into each of the two holes you just drilled:

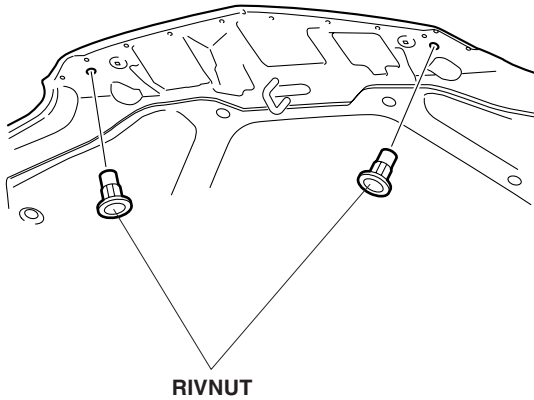

- Thread the rivnut onto the mandrel of the tool.

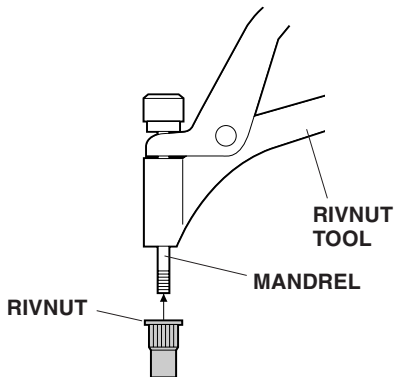

- Insert the rivnut into the hole in the hood panel.

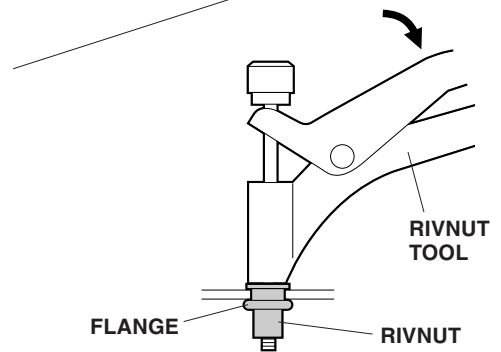
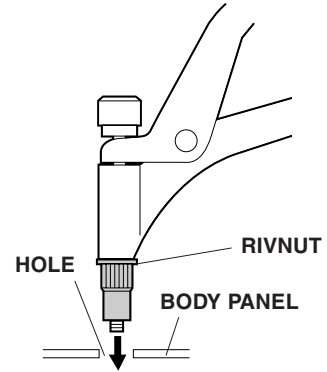

- Squeeze the handle firmly until the rivnut is compressed to form a flange-like stopper under the body panel.
 - Release the handle, turn the mandrel, and remove the tool from the rivnut.
4. Locate the two square holes near the edge of the hood. Insert one plastic grommet into each of the two square holes.

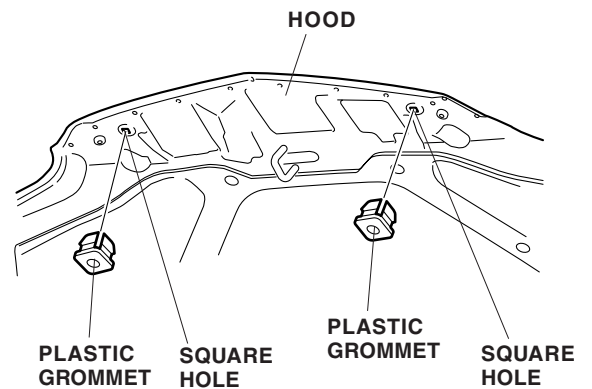

- Temporarily slide the front brackets over the lip of the hood, and align the hole in the bracket with the hole in the plastic grommets. Install the long screws (one screw for each bracket).

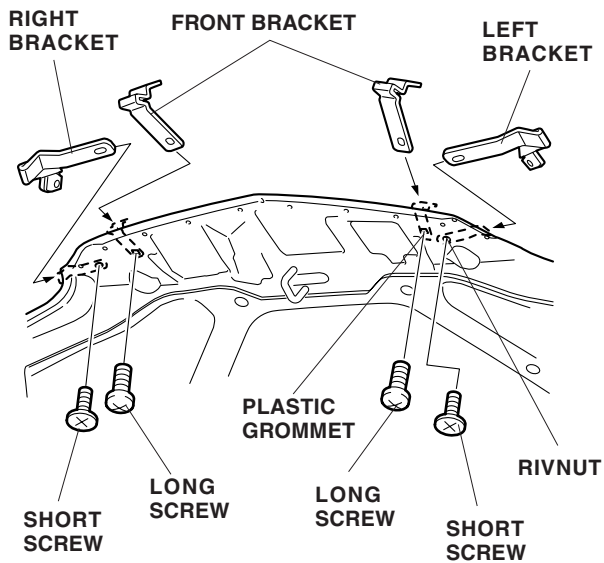

- Temporarily slide the right and left brackets over the lip of the hood, and align the hole in the bracket with the rivnut. Install the short screws (one screw for each bracket).
- Attach a piece of masking tape to the hood under each front bracket and side bracket.

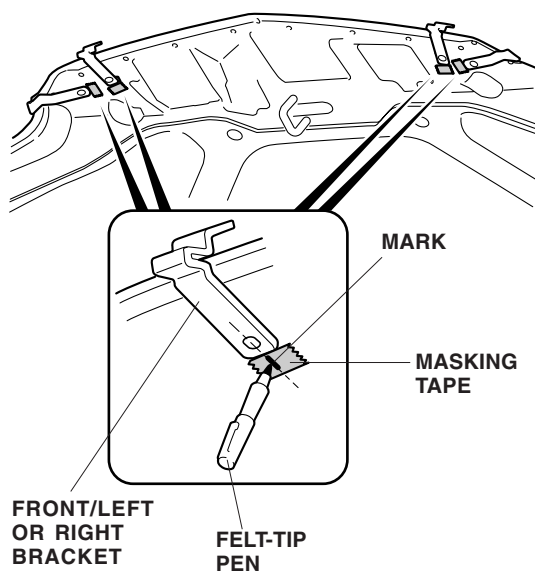

- Using a felt-tip pen, mark the masking tape where each bracket will be positioned, then remove all of the brackets.

- Using an alcohol pad, clean the areas where the protective tapes will attach.

PROTECTIVE TAPES (5)

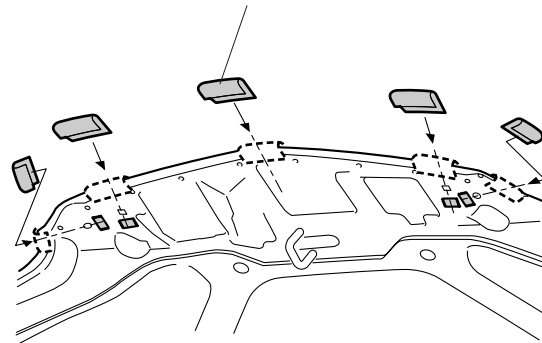

- Attach four protective tapes around the front of the hood at each marked location. Attach one protective tape around the center of the hood. Remove the masking tapes.
- Reinstall the front brackets to the hood over the protective tapes. Don't tighten the long screws at this time.

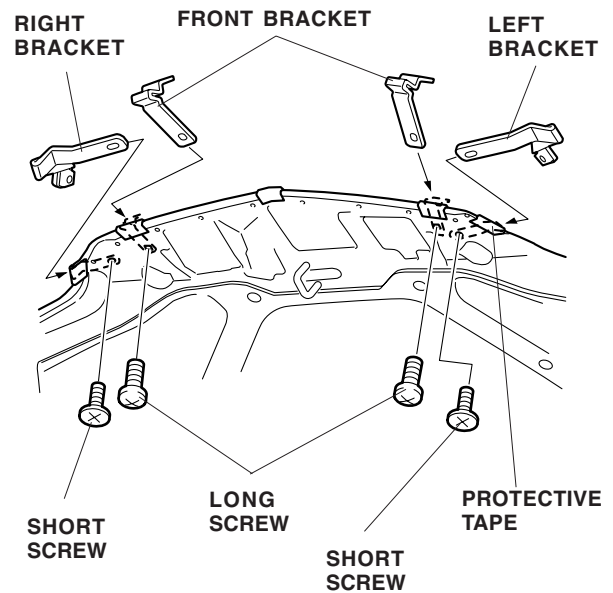

- Reinstall the right and left brackets to the hood over the protective tapes. Don't tighten the short screws at this time.

13. Install the rubber molding to the front edge of the hood above the front brackets. Push the eight clips on the rubber molding into the holes in the hood.

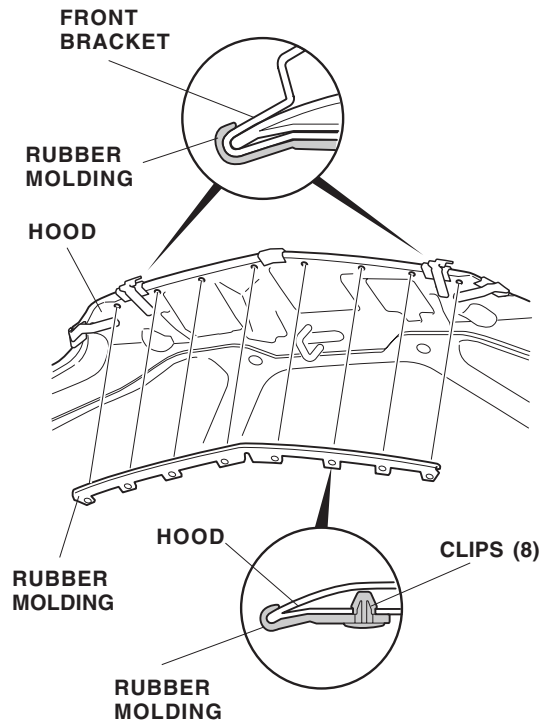

14. Close the hood. Measure and mark the center of the hood.

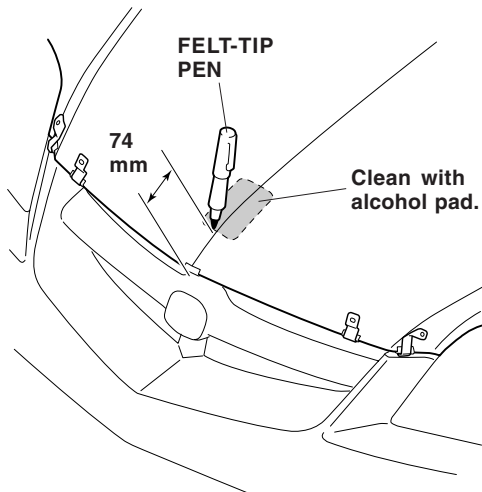

15. Using an alcohol pad, clean the area where the center support will attach.

16. Remove the adhesive backing from the center support and attach it to the hood at the mark you made. The arrow on the center support should point to the front of the vehicle.

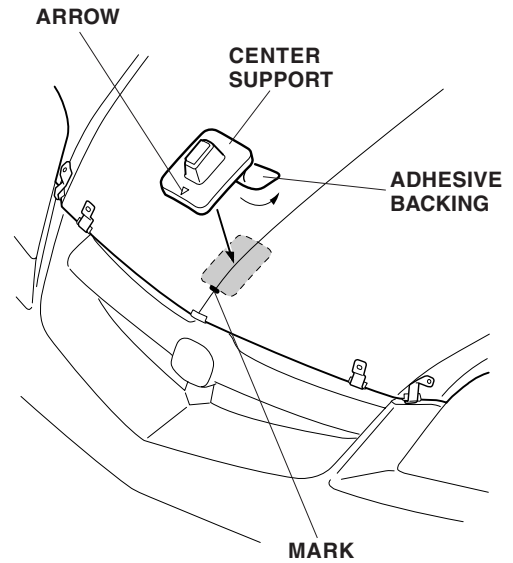

17. Attach the center bracket to the air deflector with the two clips and one washer over the elongated hole in the center bracket.

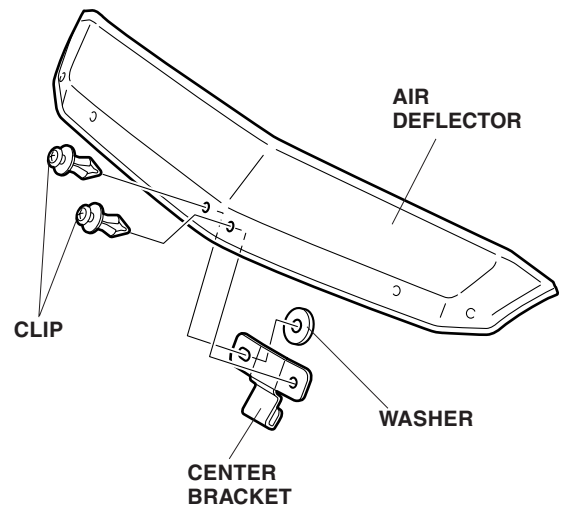

18. Position the air deflector on the hood by sliding the center bracket over the protective tape on the hood. Align the holes in the air deflector over the four bracket holes and install the two short screws with collars, and two clips with washers. Tighten the short screws. Make sure the center bracket is between the rubber molding and hood.

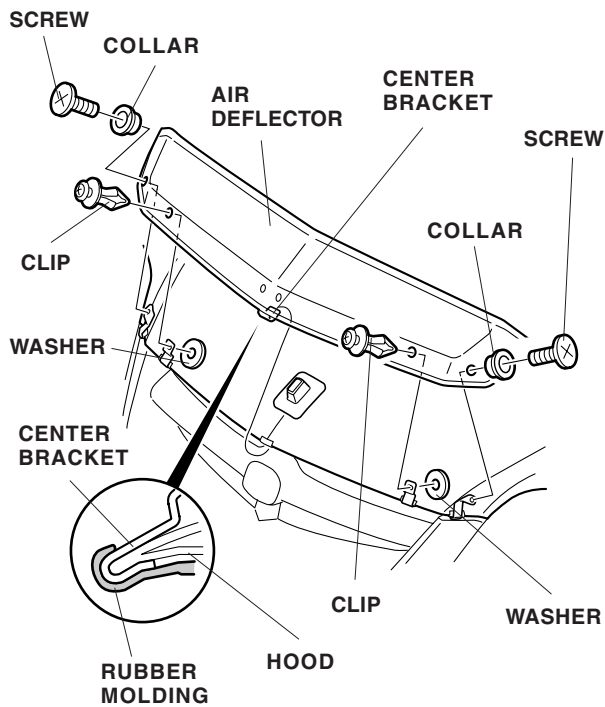

19. Open the hood. Push the front brackets and side brackets against the hood while you tighten the two long screws, and the two short screws.

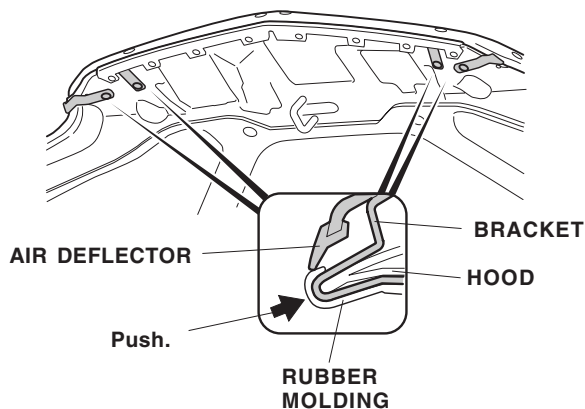

20. Install protective tape to the bumper at the bracket location:

- Using scissors, cut one protective tape in half.
- Close the hood by pressing down on the top of the air deflector center support.
- Using masking tape, mark the bumper on both sides of the left bracket.

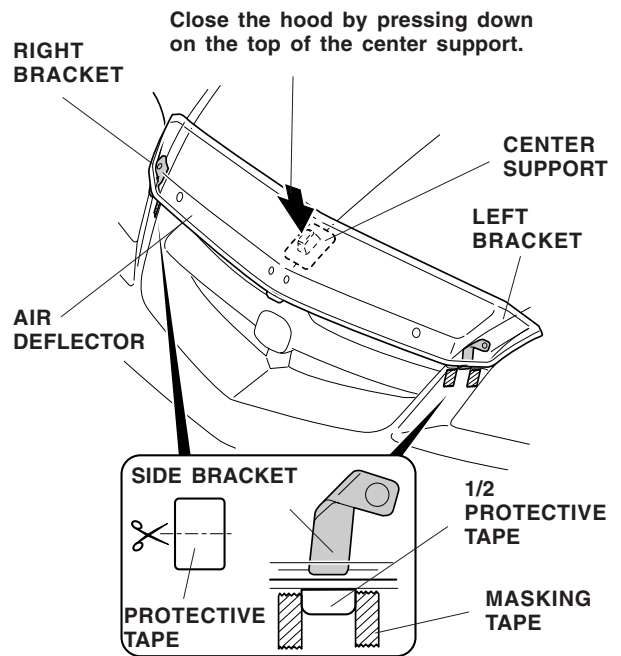

- Open the hood. Using an alcohol pad, clean the front bumper between the masking tape where the protective tapes will attach:
- Remove the adhesive backing, and install one piece of cut protective tape to the bumper between the masking tapes.
- Remove the masking tapes.
- Close the hood, and repeat step 20 to install a protective tape to the bumper on the right side of the vehicle.

**PROTECTIVE TAPE
ATTACHING SURFACE**
(Clean with an alcohol pad.)

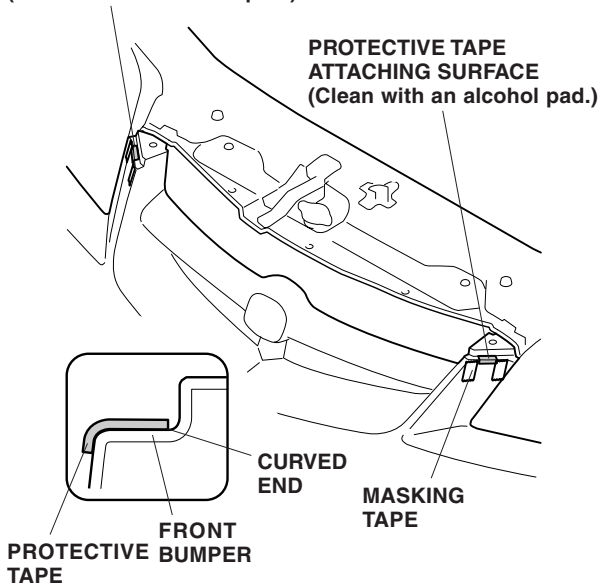

21. Using isopropyl alcohol, thoroughly clean the area shown where the hood label will attach.

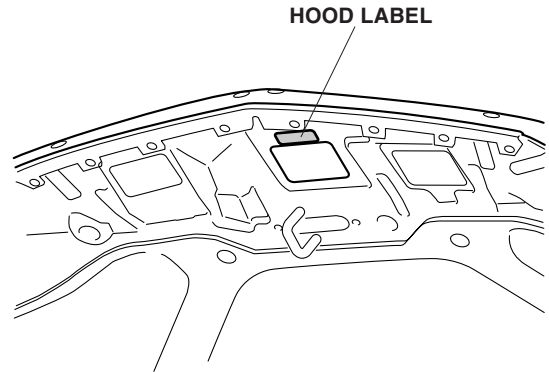

22. Remove the adhesive backing from the hood label and attach it to the hood in the area shown.

NOTE: To allow the adhesive time to cure, do not wash the vehicle for 24 hours.