

INSTALLATION INSTRUCTIONS

Accessory
BODY SIDE MOLDING

Application
2003 MDX

Publications No.
BII 24545
Issue Date
NOV 2002

PARTS LIST

2 Front side moldings

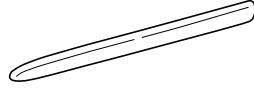

2 Rear side moldings

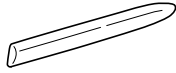

Template

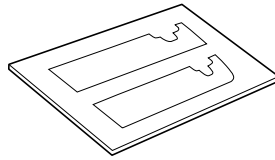

SUPPLIES REQUIRED

Tape measure

Isopropyl alcohol

Shop towel

Felt-tip pen

Masking tape

INSTALLATION

NOTE:

- Be careful not to damage the body paint finish.
- This molding kit should only be installed if the ambient air temperature is 60°F (15°C) or above.
- These instructions show the left side molding being installed; the same procedure applies to installing the right body side molding.

Attaching the Template to the Door Panel

1. Cut out the templates from the sheet.

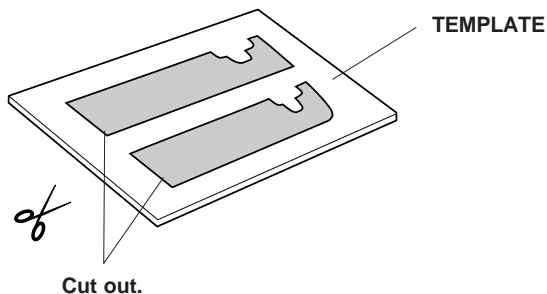

2. Using isopropyl alcohol on a shop towel, clean the areas where the body side moldings will attach.
3. Position the front template on the front door, and align the front and rear edges of the template with the front and rear edges of the front door, and the upper edge of the template with the character line and door handle line on the door panel.

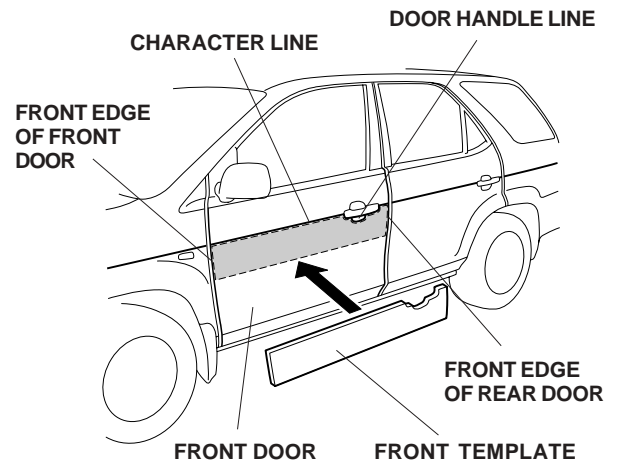

4. While holding the template in position, apply masking tape in the areas shown.

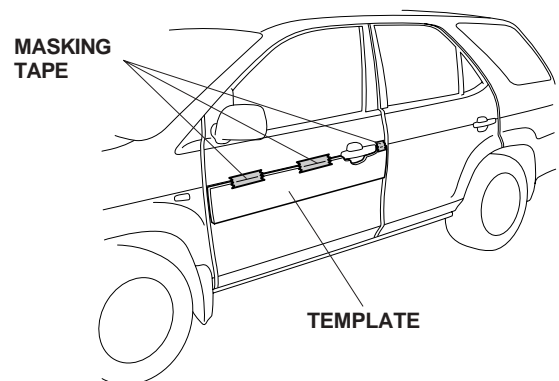

5. Repeat steps 2 and 4 to install the rear template to the rear door.

Installing the Front Body Side Moldings

- Remove 4 to 5 inches of adhesive backing from each end of the front door molding, and fold them back as shown.

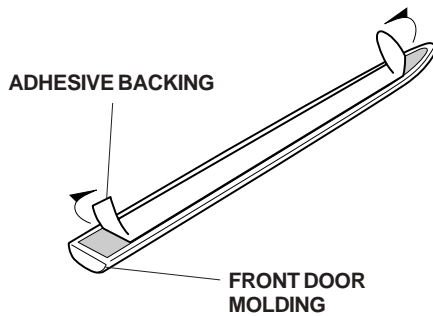

- Position the molding on the door panel and align the upper edge of the molding with the lower edge of the template. Adjust the location so that there is a 2 mm gap between the rear edge of the molding and the front door.

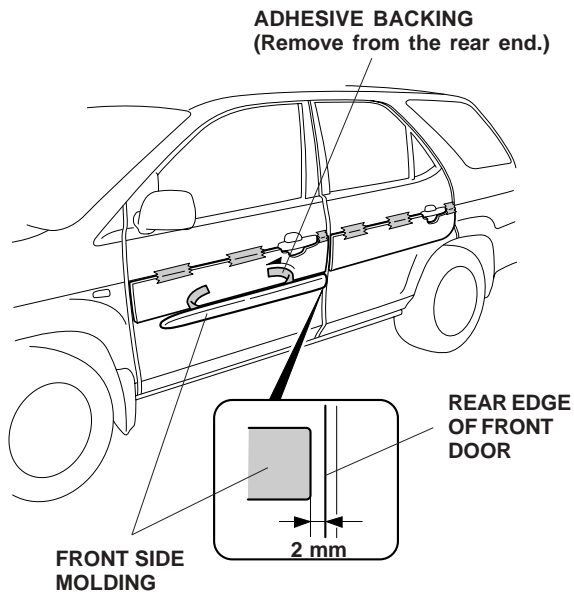

- While holding light pressure against the molding, slowly and carefully remove the adhesive backing starting at the rear and working toward the front. Hold the molding firmly against the door panel with the palm of your hand for 30 seconds.

Installing the Rear Body Side Moldings

- Remove 4 to 5 inches of adhesive backing from each end of the rear door molding, and fold them back as shown.

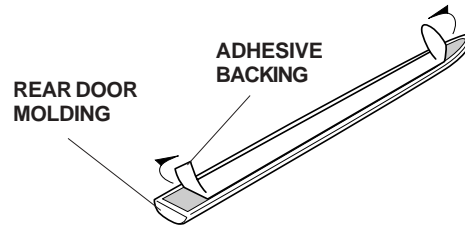

- Position the rear molding on the door panel and align the upper edge of the molding with the lower edge of the template. Adjust the location so that there is a 2 mm gap between the front edge of the molding and the rear door. Make sure that the molding does not interfere with the front door when the rear door is opened and closed.

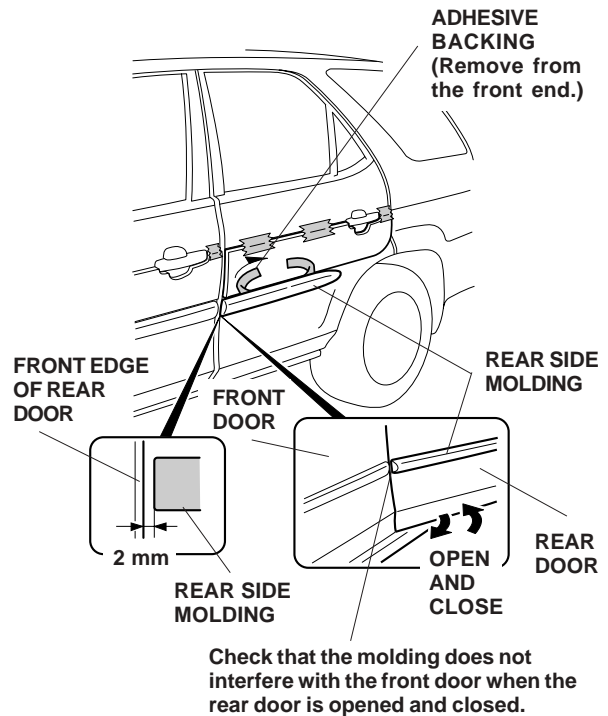

- While holding light pressure against the molding, slowly and carefully remove the adhesive backing starting at the front and working toward the rear. Hold the molding firmly against the door panel with the palm of your hand for 30 seconds.
- Remove the template.
- Turn the template over, and repeat steps 1 through 12 to install the body side moldings on the right side of the vehicle.
- To allow the adhesive to cure, tell your customer not to wash the vehicle for 24 hours.