

INSTALLATION INSTRUCTIONS

Accessory

**TRAILER HITCH
P/N 08L92-S3V-200**

Application

2002 MDX

Publications No.

BII 23300

Issue Date

NOV 2001

PARTS LIST

Trailer hitch

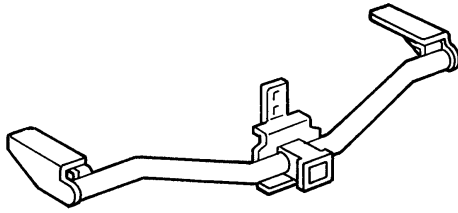

Ball mount

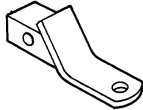

Hitch pin



Hitch pin clip



8 Bolts, 12 x 40 mm



2 Bolts, 10 x 30 mm



2 Bolts, 8 x 20 mm



8 Plain washers, 12 mm



2 Plain washers, 10 mm



2 Plain washers, 8 mm



8 Spring washers, 12 mm



2 Spring washers, 10 mm



2 Spring washers, 8 mm



2 Spacers



Trailer hitch harness

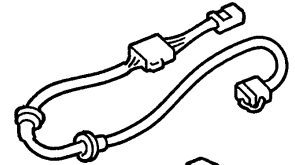

2 Short wire ties



2 Long wire ties



Clip



Washer-bolt



Nut



Bracket

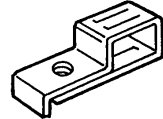

Receiver cover

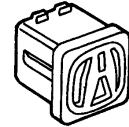

TOOLS AND SUPPLIES REQUIRED

Phillips screwdriver

Clip remover

Diagonal cutters

Ratchet

10 mm, 13 mm, 17 mm, and 19 mm Sockets

Isopropyl alcohol

Shop towel

10 mm Wrench

INSTALLATION

NOTE:

- Optional ATF and power steering coolers are required when installing the trailer hitch. Have the recommended coolers available so they can be installed.
- Be careful not to damage the rear bumper or other finished surfaces of the body.

1. Open the tailgate, and remove the cargo lid.

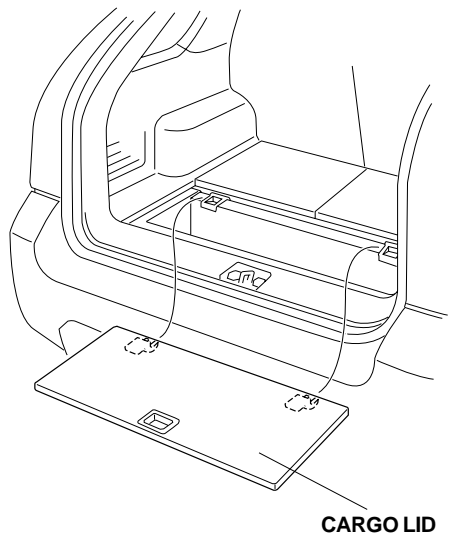

2. Remove the two clips fastening the rear trim, and remove the rear trim.

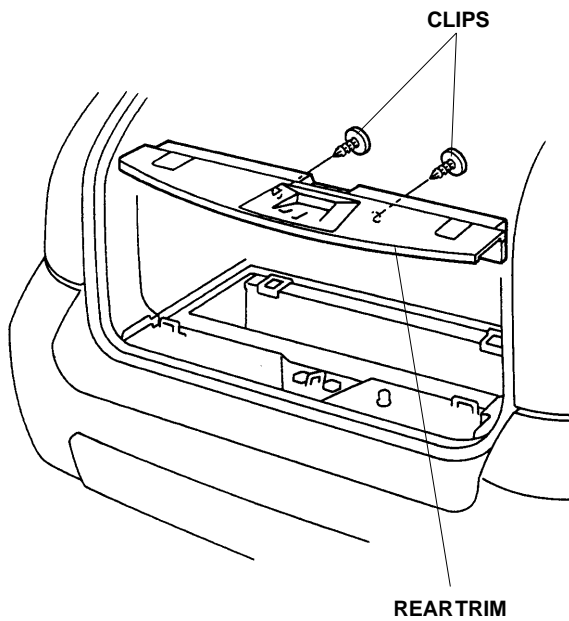

3. Remove the large grommet from the hole in the bottom of the body frame.

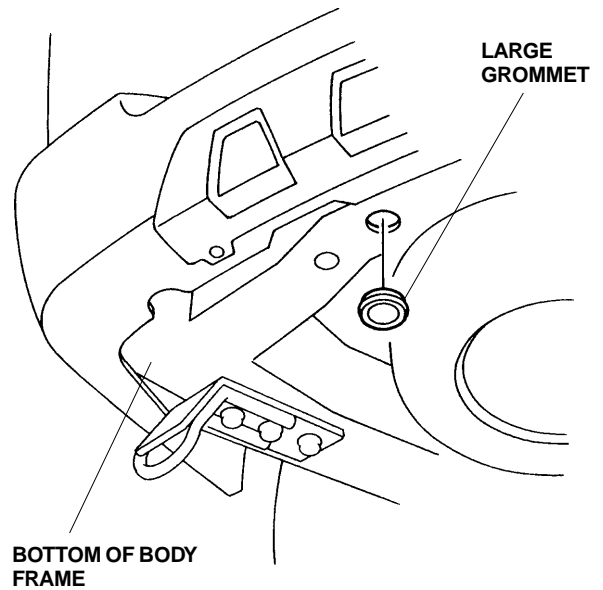

4. Remove the grommet from the body panel.

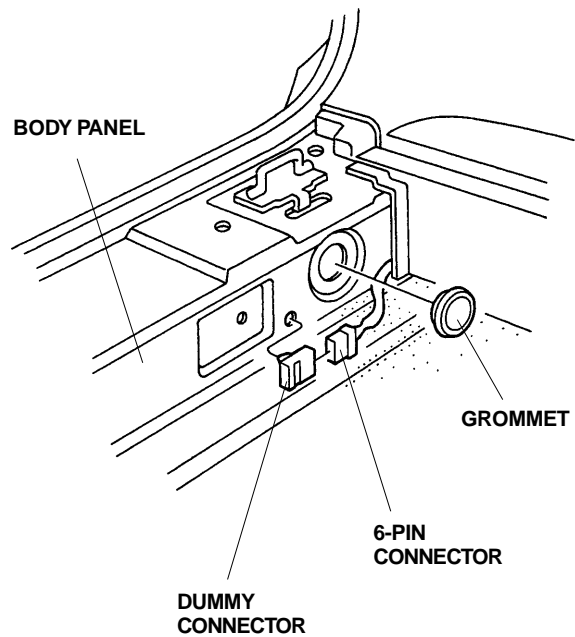

5. Remove the 6-pin connector from the body. Remove and discard the dummy connector from the 6-pin connector.

6. Cut off the two tabs from the converter of the trailer hitch harness as shown.

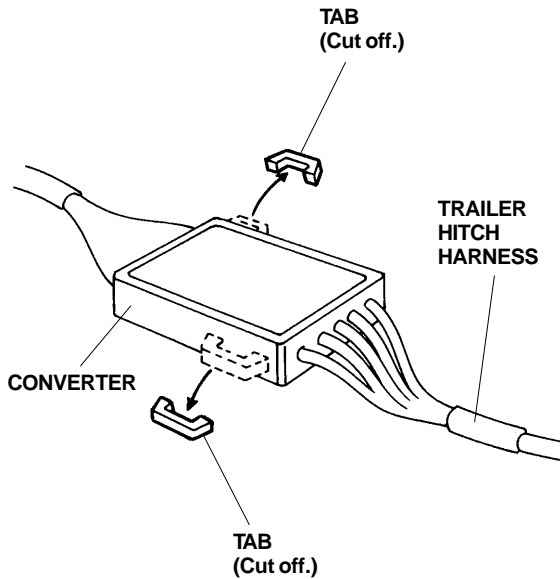

7. Get the clip from the kit, and attach it to the 6-pin connector of the trailer hitch harness.

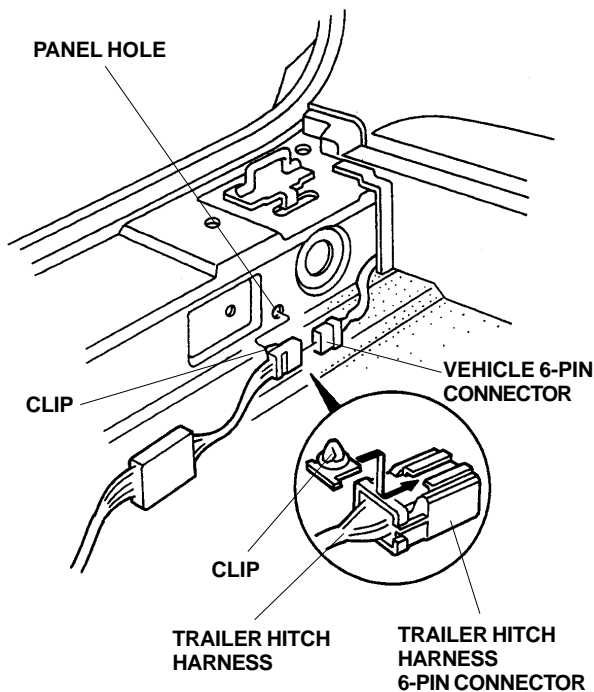

8. Plug the 6-pin connector of the trailer hitch harness into the 6-pin connector of the vehicle harness, then push the clip you just installed into the panel hole.

9. Remove the adhesive backing from the back of the converter, then attach it to the body panel in the area shown. Before attaching, thoroughly clean the body panel surface with isopropyl alcohol.

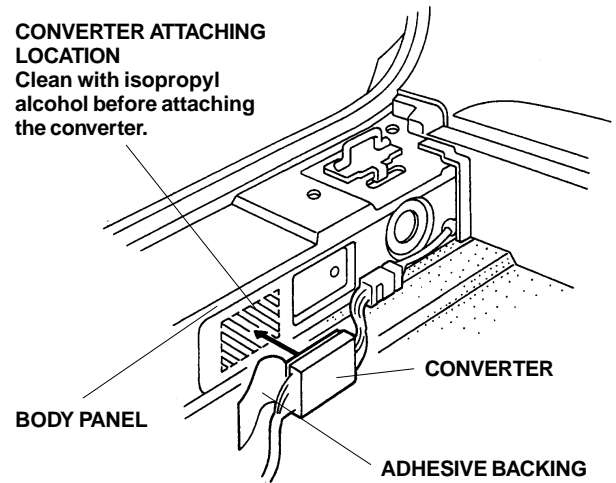

10. Route the 6-pin connector of the trailer hitch harness through the hole in the cargo area and out through the hole in the bottom of the body.

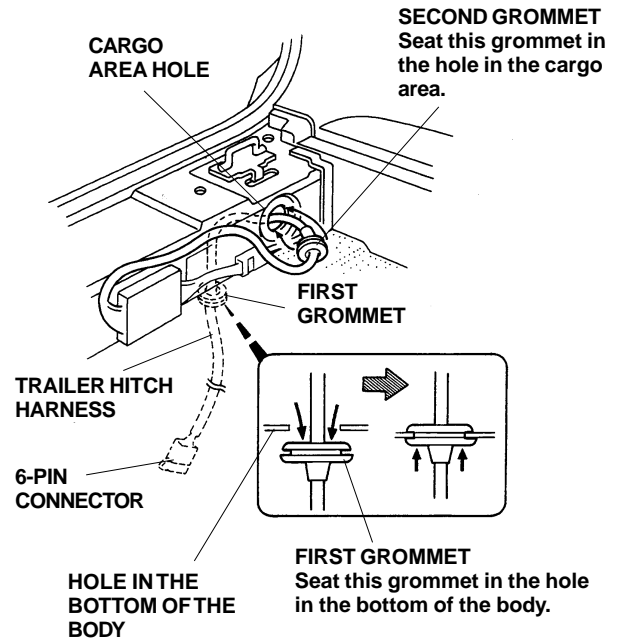

11. Pull the first grommet through the hole in the cargo area, and seat the first grommet in the hole in the bottom of the body. Seat the second grommet into the hole in the cargo area.

- Secure the trailer hitch harness to the 6-pin connector with two short wire ties in the areas shown, then reinstall the rear trim.

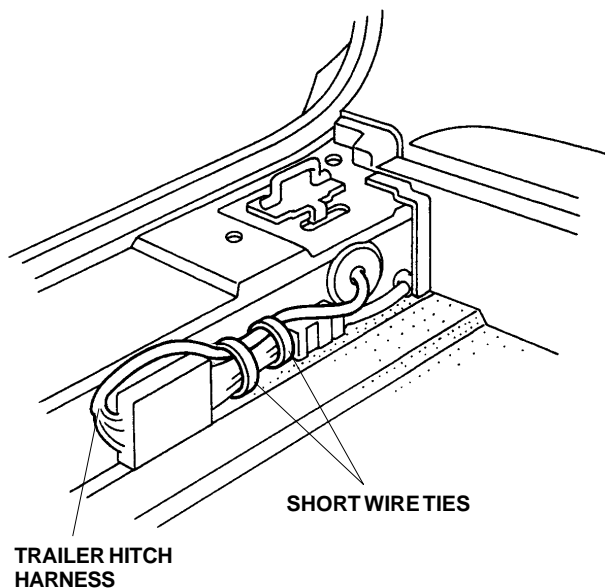

- Remove the tow hook (three bolts). Save the tow hook for your customer.

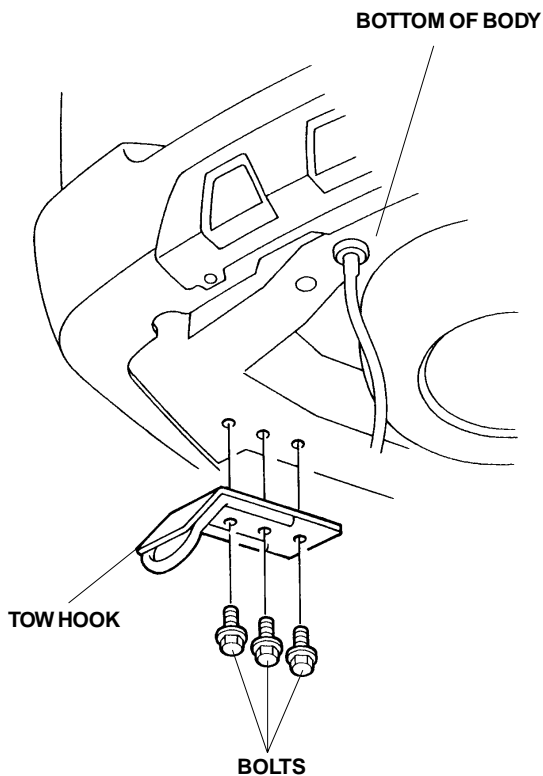

- When the exhaust system is cooled down, remove the two rubber mounts from the bottom of the body, and lower the exhaust pipe.

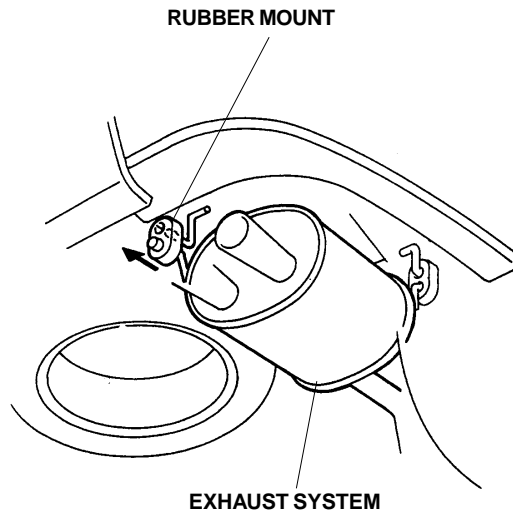

- Lower the spare tire.
- With the help of an assistant, install the trailer hitch on the body, using the eight 12 x 40 mm bolts, eight 12 mm plain washers, and eight 12 mm spring washers.

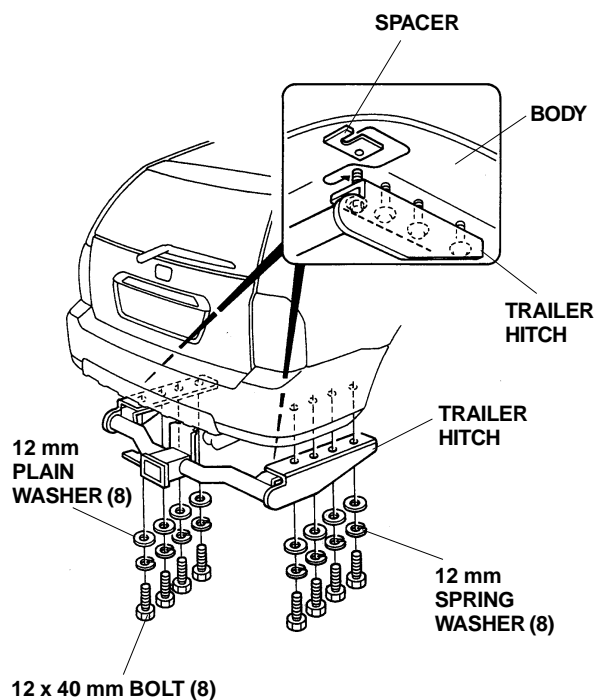

- Insert one spacer between the trailer hitch and the body. Do not tighten the trailer hitch at this time.

18. Loosely install the two 10 x 30 mm bolts, two 8 x 20 mm bolts, two 10 mm plain washers, two 8 mm plain washers, two 10 mm spring washers, and two 8 mm spring washers.

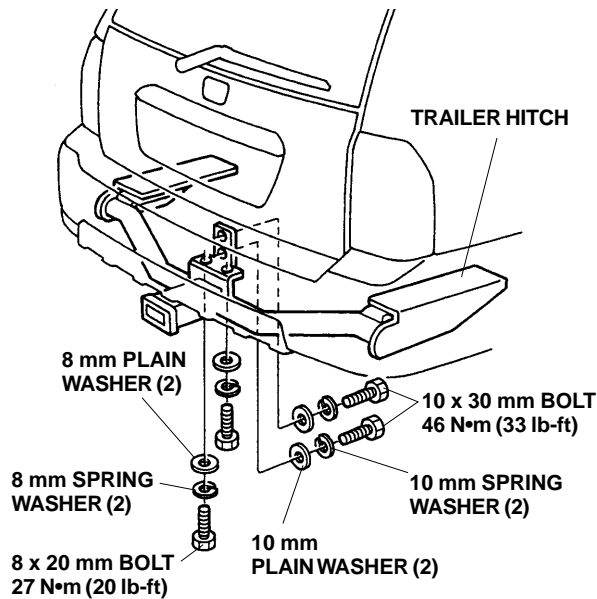

19. Torque the trailer hitch mounting bolts in this order:

- Eight 12 x 40 mm bolts (installed in step 16) to 80 N•m (58 lb-ft).
- Two 10 x 30 mm bolts to 46 N•m (33 lb-ft).
- Two 8 x 20 mm bolts to 27 N•m (20 lb-ft).

20. Install the socket of the trailer hitch harness on the trailer hitch.

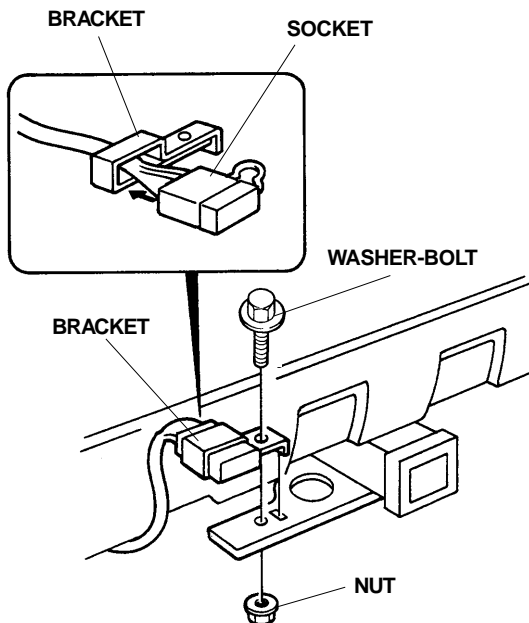

21. Install the bracket on the trailer hitch with the washer-bolt and nut.

22. Secure the trailer hitch harness to the trailer hitch with two long wire ties in the areas shown.

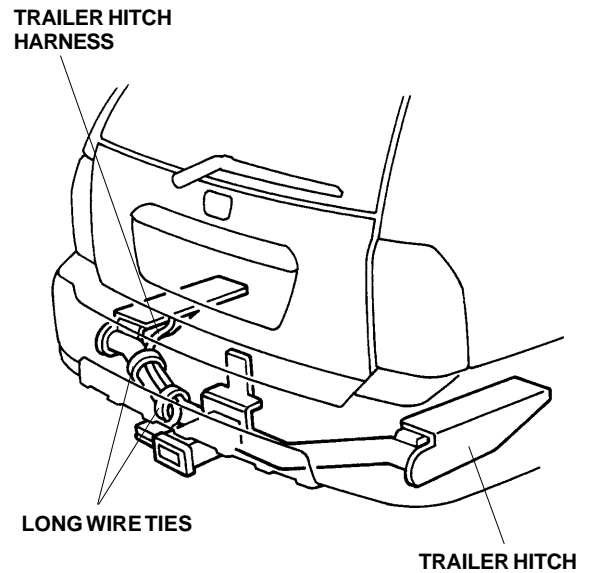

23. Slide the ball mount into the opening at the end of the trailer hitch.

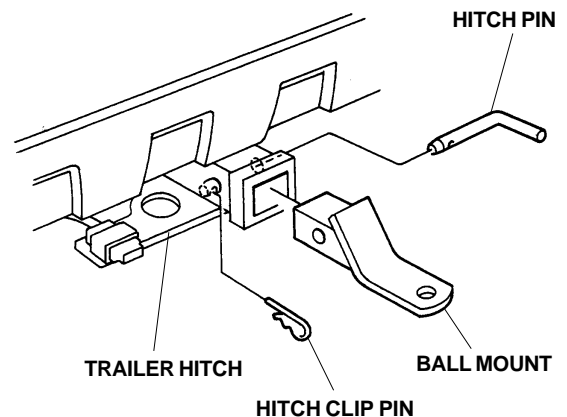

24. Slide the hitch pin through the trailer hitch and ball mount, then install the hitch pin clip in the hole in the end of the hitch pin.

25. Reinstall the muffler, and raise the spare tire back into position.

26. Reinstall the rear trim and the cargo lid.

27. Store the tow hook (removed in step 13) in the cargo area.

Put a Copy of This Page in the Glove Box for Your Customer

Installing the Receiver Cover

Whenever you remove the hitch pin clip, the hitch pin, and the ball mount, store them securely in the cargo area. Then press the receiver cover into the opening at the end of the trailer hitch. When you reinstall the ball mount, store the receiver cover in the cargo area.

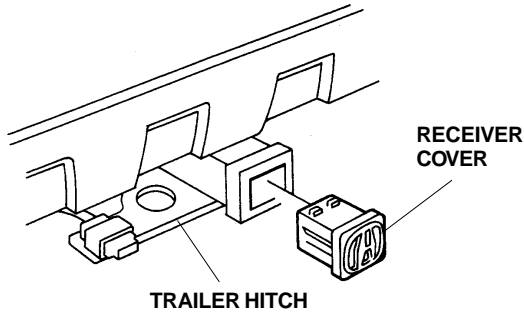

FUSE LOCATIONS

Primary Under-Hood Fuse Box

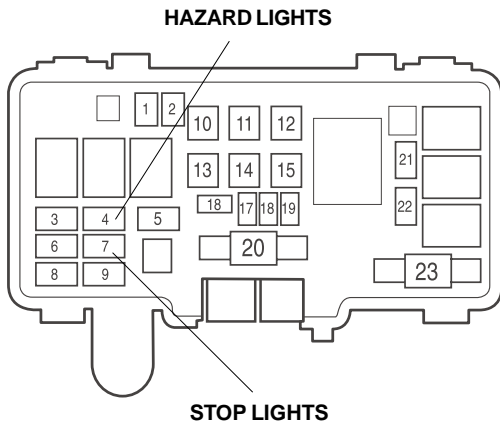

Interior Fuse Box (Driver's Side)

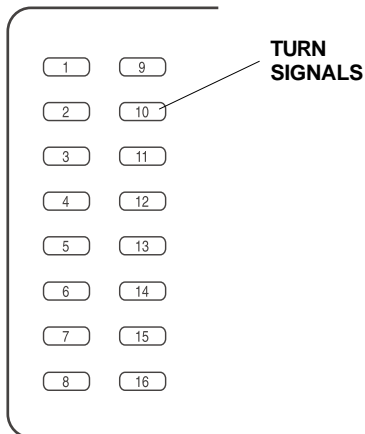

Interior Fuse Box (Passenger's Side)

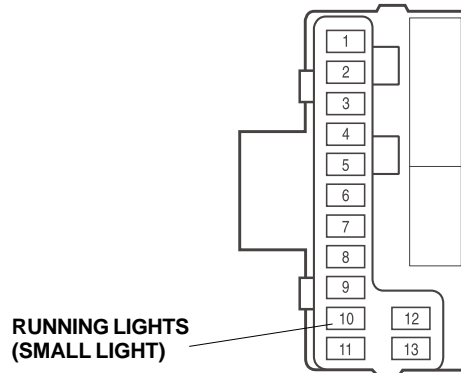

WIRING INFORMATION

To Vehicle

- R Red = Brake
- Y Yellow = Left Turn
- G Green = Right Turn
- BR Brown = Running Lights (Small Lights)
- W White = Ground

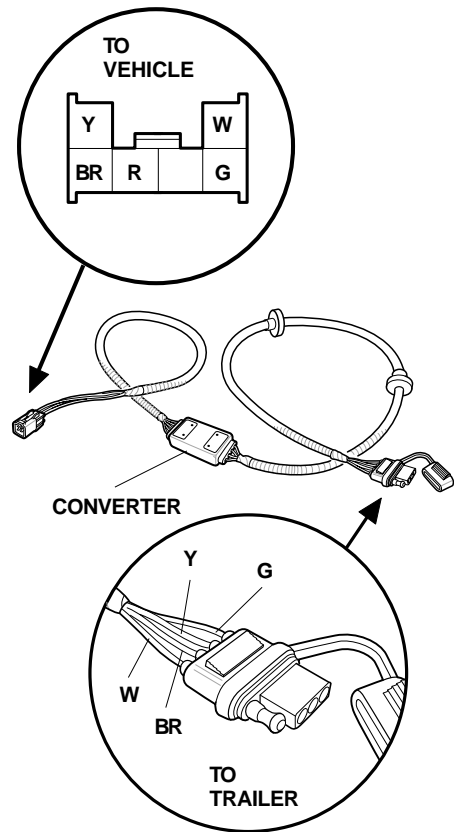

To Trailer

- Y Yellow = Brake/Left Turn
- G Green = Brake/Right Turn
- BR Brown = Running Lights (Small Lights)
- W White = Ground