



INSTALLATION INSTRUCTIONS

Accessory

RUNNING BOARDS
P/N 08L33-S3V-200

Application

2001 MDX

Publications No.

BII 21503

Issue Date

SEP 2000

PARTS LIST

2 Running boards

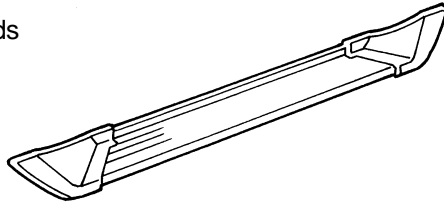

6 "A" Brackets

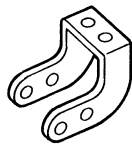

6 "B" Brackets

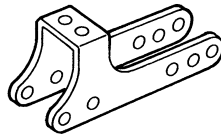

6 "C" Brackets

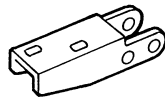

24 Long flange bolts



48 Short flange bolts



60 Flange nuts



TOOLS AND SUPPLIES REQUIRED

Ratchet

13 mm Socket

10 mm Combination wrench

Cardboard or blanket

Torque wrench

INSTALLATION

NOTE:

- Thoroughly clean the bottom of the body from the rear of the front wheels up to the front of the rear wheels.
- Be careful not to damage the body paint finish. To prevent damage, place cardboard or a blanket under the running board during the installation.
- These instructions show the left side running board being installed; the same procedure applies to installing the right running board.

1. Assemble two front bracket assemblies using brackets "A," "B," and "C" along with 8 short flange bolts and 8 flange nuts. Leave the nuts and bolts loose at this time.

Front Bracket Assembly:

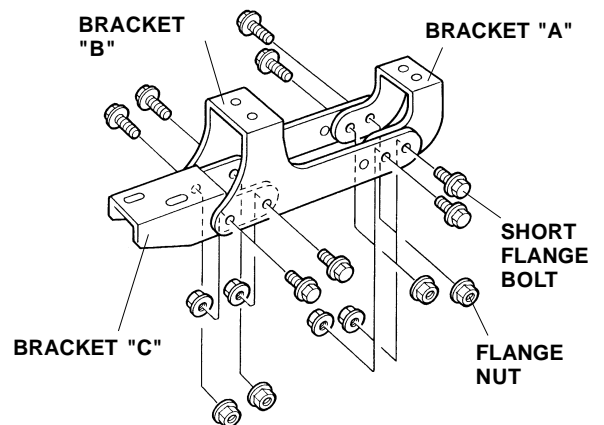

2. Assemble four center and rear bracket assemblies using brackets "A," "B," and "C" along with 8 short flange bolts and 8 flange nuts. Leave the nuts and bolts loose at this time.

Center and Rear Bracket Assembly:

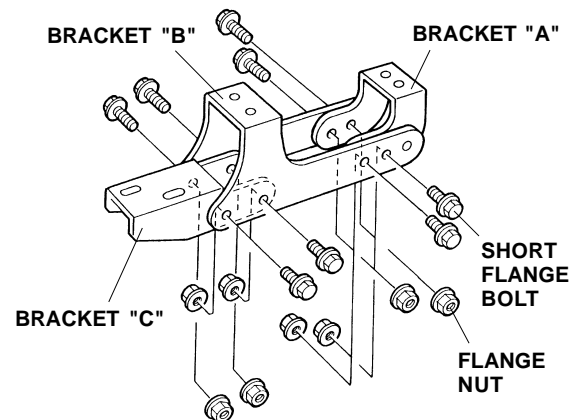

- At the left side of the vehicle, install one bracket assembly at the front, one at the center, and one at the rear along the body using 12 long flange bolts. Thread the long flange bolts in about 3 or 4 threads.

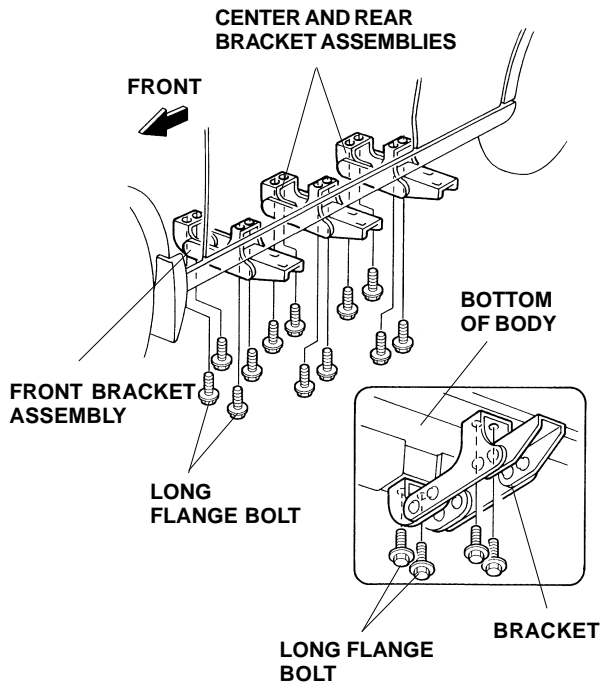

- Insert six short flange bolts (three per slot) into the slots on the bottom of one running board. Set the running board on the brackets with the flange bolts through the holes in the brackets. Install the six flange nuts on the ends of the bolts, but don't tighten them yet.

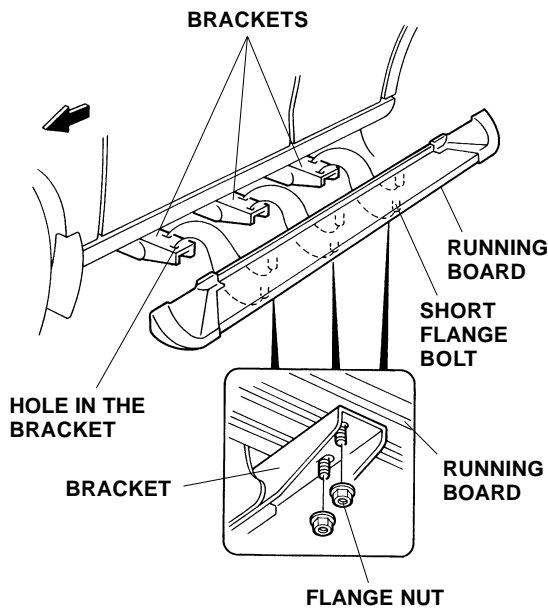

- Align the rear of the running board with the end of the inner fender, then tighten the long flange bolts you installed in step 3. Torque the long flange bolts to 24 N•m (18 lb-ft).

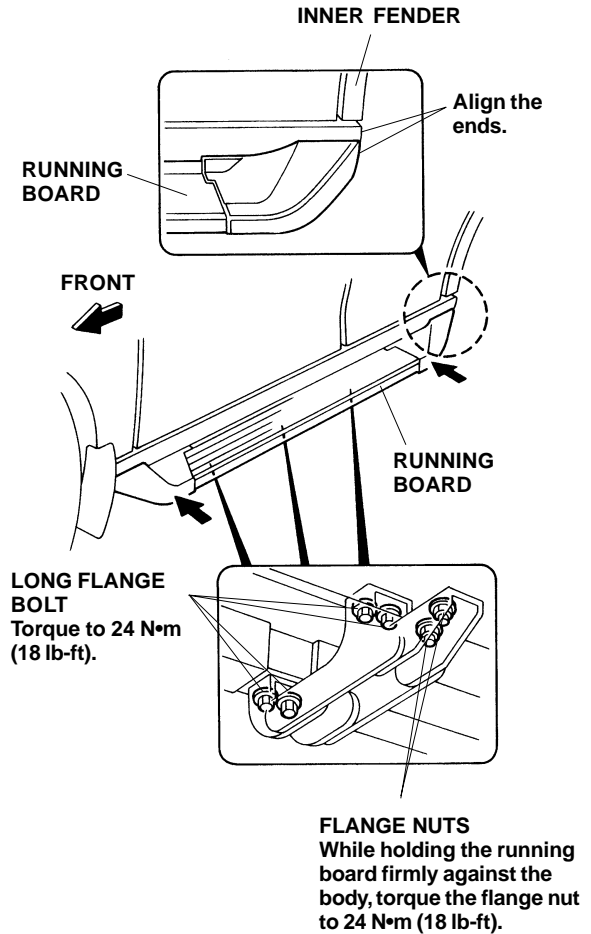

- Torque the short flange bolts you installed in steps 1 and 2 to 24 N•m (18 lb-ft).
- While holding the running board firmly against the body, torque the flange nuts to 24 N•m (18 lb-ft).
- Repeat steps 3 through 7 to install the running board on the right side of the vehicle.